

INDEX



JR-700

<i>GROUP</i>	<i>PAGE</i>
Frame Group	2
Cable Drum Assembly Group.....	4
Wheel Group.....	6
Rotor Group.....	8
Backstop Group.....	10
Hydraulics Group.....	12
Cross Conveyor Group	14
Miscellaneous Group	16
Notes	17

FRAME GROUP



JR-700

REF. NO.	PART NO.	QTY	DESCRIPTION
1	2A	1	Frame Assembly
2	2B	1	Rotor Access Plate - Drive Side
3	2C	1	Rotor Access Plate - Idler Side
4	2D	1	Jack - 5,000 Lb.
5	2E	1	Snap Ring - 2 1/2"
6	2F	1	Lock Pawl Replacement Kit
7	2G	1	Face Plate
8	2H	1	Front Shroud
9	2I	1	Side Shroud
10	2J	1	End Extension
11	2K	15	Capscrew - 1/4" N.C. x 3/4" Long - Grade 5
12	2L	15	Hexnut - 1/4" N.C. Nylok
13	2M	3	Face Plate Mounting Arm
14	2N	6	Capscrew - 5/16" N.C. x 2" Long - Grade 5
15	2O	6	Hexnut - 5/16" N.C. Nylok
16	2P	8	Capscrew - 7/16" N.C. x 1 1/4" Long - Grade 5 (Not Shown)
17	2Q	8	Hexnut - 7/16" N.C. Nylok
18	2R	4	Capscrew - 3/8" N.C. x 1 1/4" Long - Grade 5
19	2S	4	Hexnut - 3/8" N.C. Nylok (Not Shown)
20	2T	30	Flatwasher - 1/4"



CABLE DRUM ASSEMBLY GROUP

JR-700

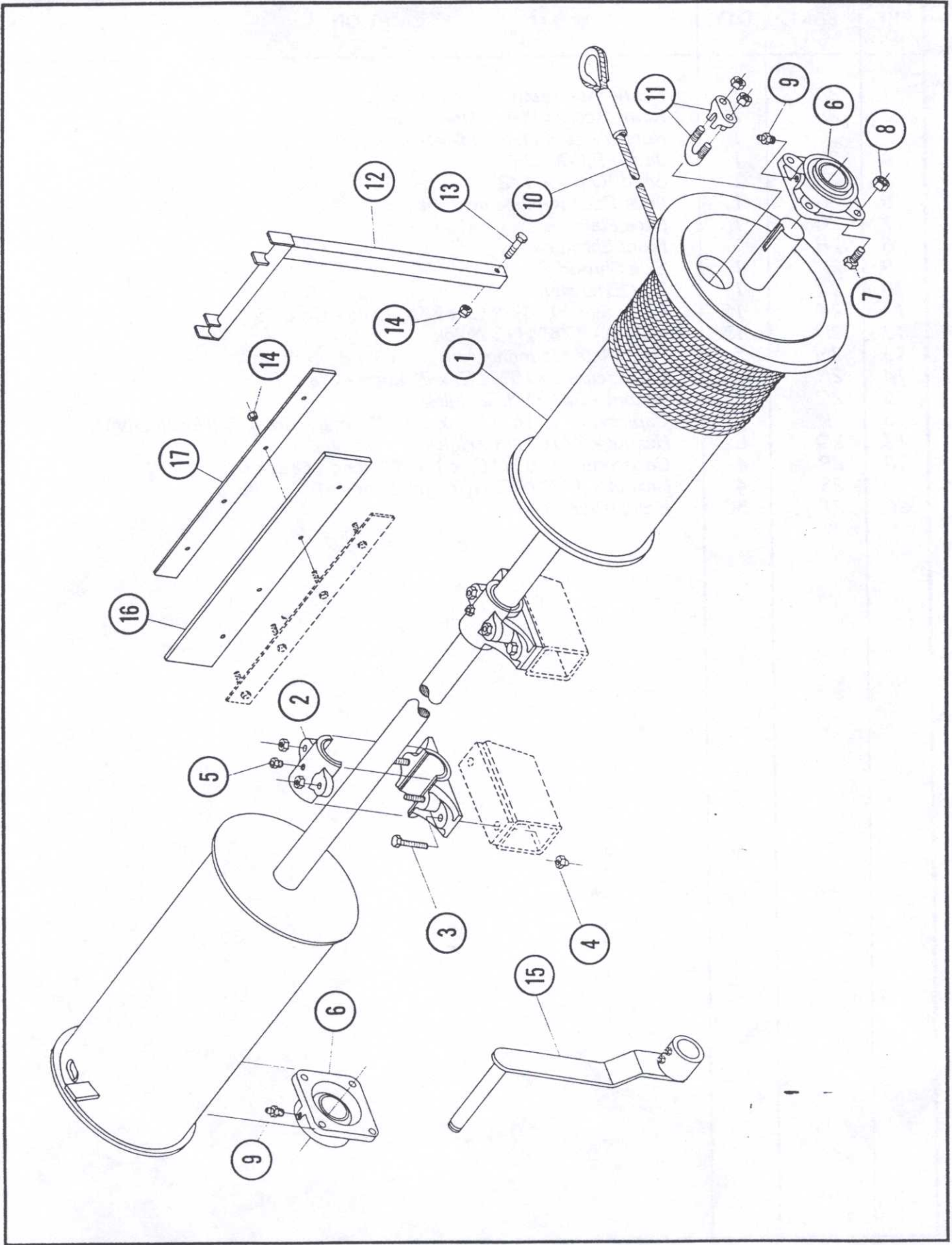

CABLE DRUM ASSEMBLY GROUP



JR-700

REF. NO.	PART NO.	QTY	DESCRIPTION
1	4A	1	Cable Drum Assembly
2	4B	2	Split Babbit Bearing
3	4C	4	Capscrew - 5/8" N.C. x 2 1/2" Long - Grade 5
4	4D	4	Hexnut - 5/8" N.C. Nylok
5	4E	2	Grease Nipple - 1/4" MNPT Straight
6	4F	2	Ball Bearing
7	4G	8	Capscrew - 1/2" N.C. x 1 3/4" Long - Grade 5
8	4H	8	Hexnut - 1/2" N.C. Nylok
9	4I	2	Grease Nipple - 1/8" MNPT Straight
10	4J	2	7/16" Galvanized Wire Rope
11	4K	2	3/8" Galvanized Wire Rope Clamp
12	4L	2	Cable Rewind Support Assembly
13	4M	2	Capscrew - 5/16" N.C. x 2" Long - Grade 5
14	4N	10	Hexnut - 5/16" N.C. Nylok
15	4O	1	Rewind Crank
16	4P	2	Cable Wipe
17	4Q	2	Cable Wipe Keeper



WHEEL GROUP

JR-700

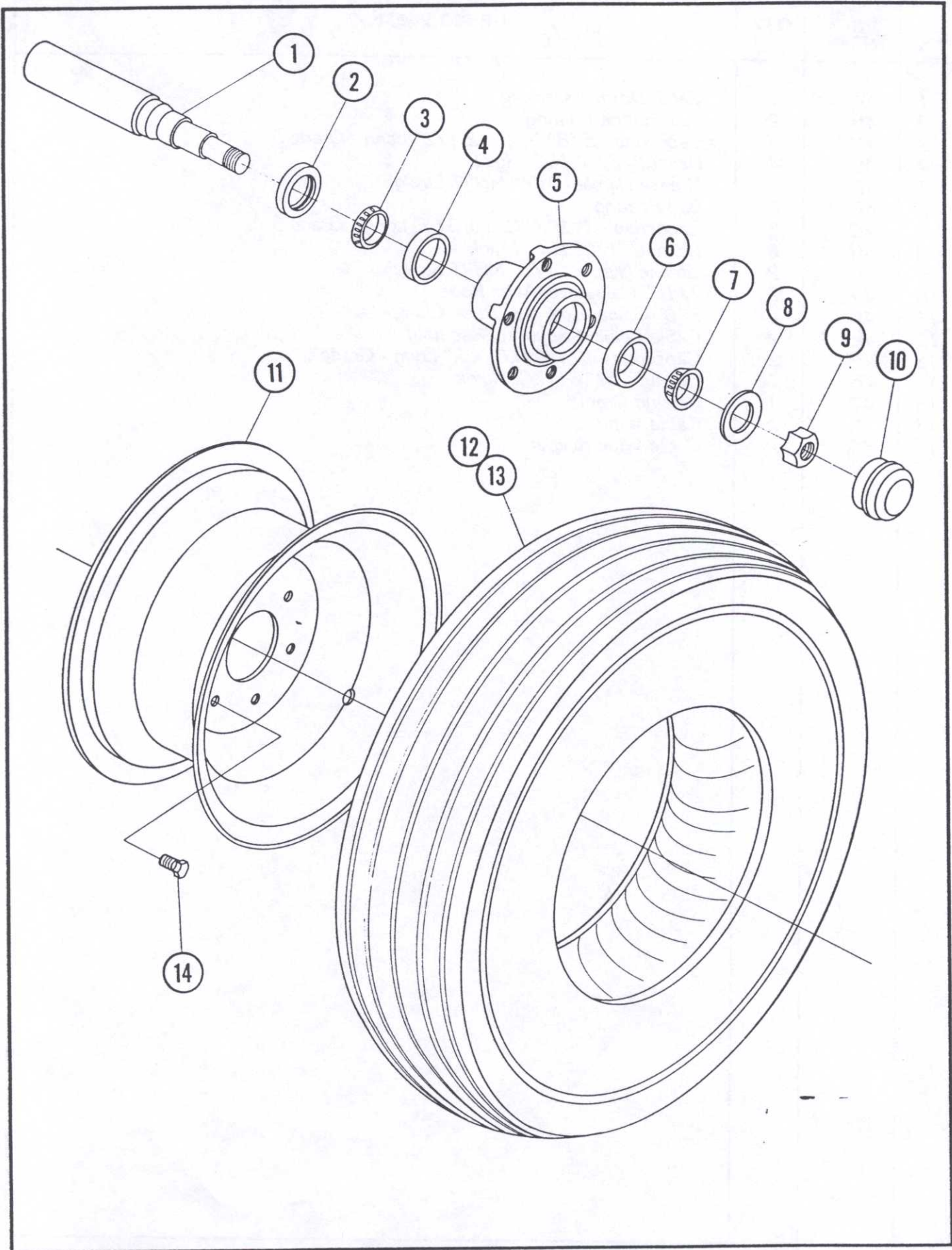

WHEEL GROUP



JR-700

REF. NO.	PART NO.	QTY	DESCRIPTION
1	6A	2	Spindle
2	6B	2	Grease Seal
3	6C	2	Inner Bearing Cone
4	6D	2	Inner Bearing Cup
5	6E	2	Hub
6	6F	2	Outer Bearing Cup
7	6G	2	Outer Bearing Cone
8	6H	2	Washer
9	6I	2	Spindle Nut - 5/8" NF Nylok
10	6J	2	Hub Cap
11	6K	2	Wheel
12	6L	2	Tire - 11L15 - 8-Ply Flotation
13	6M	2	Tire Tube - 11L15
14	6N	12	Wheel Bolt



ROTOR GROUP

JR-700

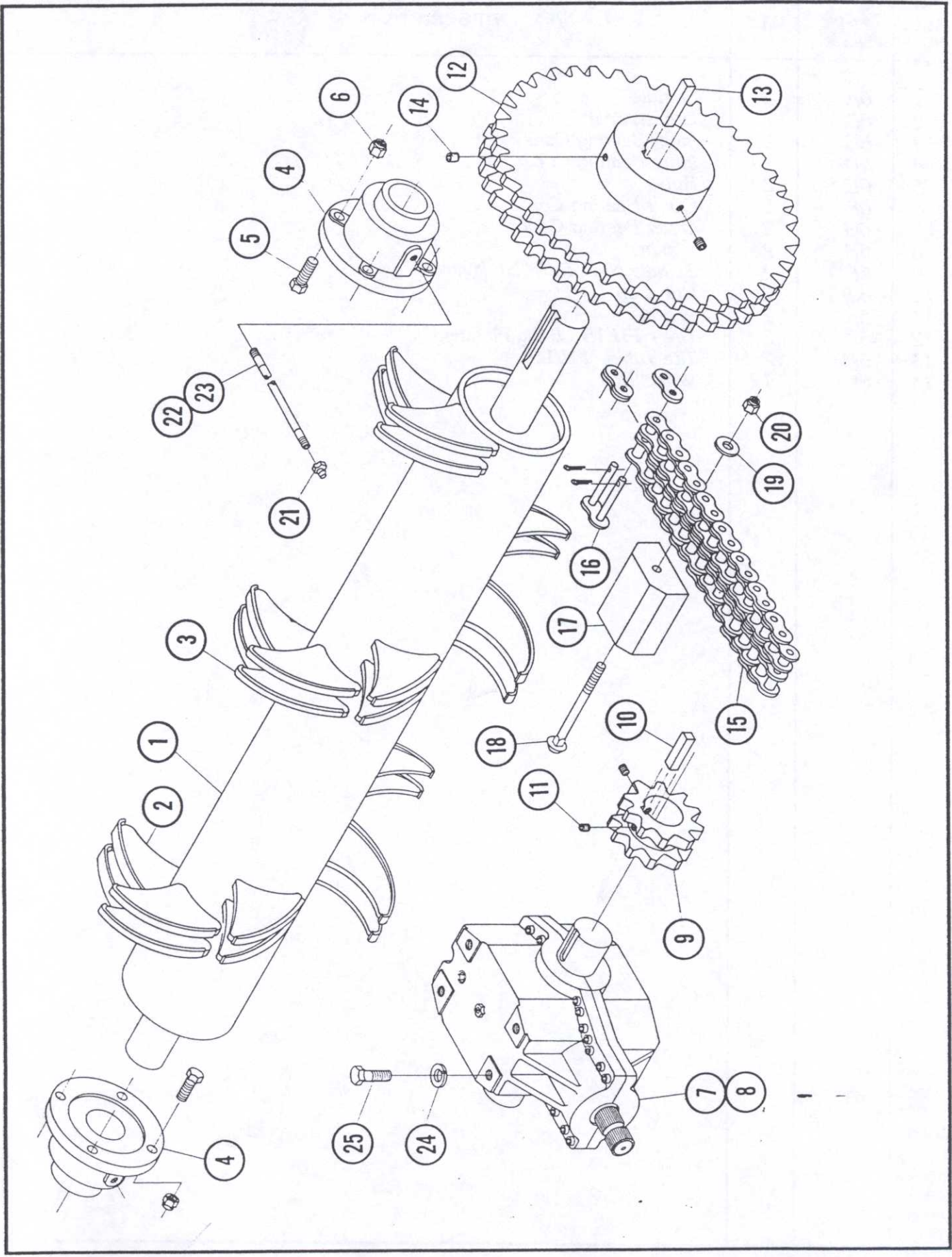

ROTOR GROUP



JR-700

REF. NO.	PART NO.	QTY	DESCRIPTION
1	8A	1	Rotor Assembly With Teeth
2	8B	30	Rotor Tooth
3	8C	30	Rotor Tooth Cap
4	8D	2	Roller Bearing - 2 15/16"
5	8E	8	Capscrew - 3/4" N.C. x 2" Long - Grade 5
6	8F	8	Hexnut - 3/4" N.C. Nylok
7	8G	1	Gearbox
8	8H	-	Gear Lube EP 80-90
9	8I	1	Drive Sprocket - #140-2 - 10 Tooth STD.
10	8J	1	Key - 5/8" x 5/8" x 3" Long
11	8K	2	Set Screw - 3/8" N.C. x 1/2" Long
12	8L	1	Driven Sprocket - #140-2 - 42 Tooth
13	8M	1	Key - 3/4" x 3/4" x 4" Long
14	8N	2	Set Screw - 1/2" N.C. x 1/2" Long
15	8O	1	Chain - #140-2
16	8P	1	Offset Link - #140-2
17	8Q	1	Tensioner
18	8R	1	Carriage Bolt - 5/8" N.C. x 7 1/2" Long
19	8S	1	Flatwasher 9/16"
20	8T	1	Hexnut - 5/8" N.C. Nylok
21	8U	2	Grease Nipple - 1/8" FNPT Straight
22	8V	1	Grease Hose x 20" Long - L.H. 1/8" NPT Both Ends
23	8W	1	Grease Hose x 26" Long - R.H. 1/8" NPT Both Ends
24	8X	7	Lockwasher - 5/8"
25	8Y	7	Capscrew - 5/8" N.C. x 2" Long - Grade 5



BACKSTOP GROUP
JR-700

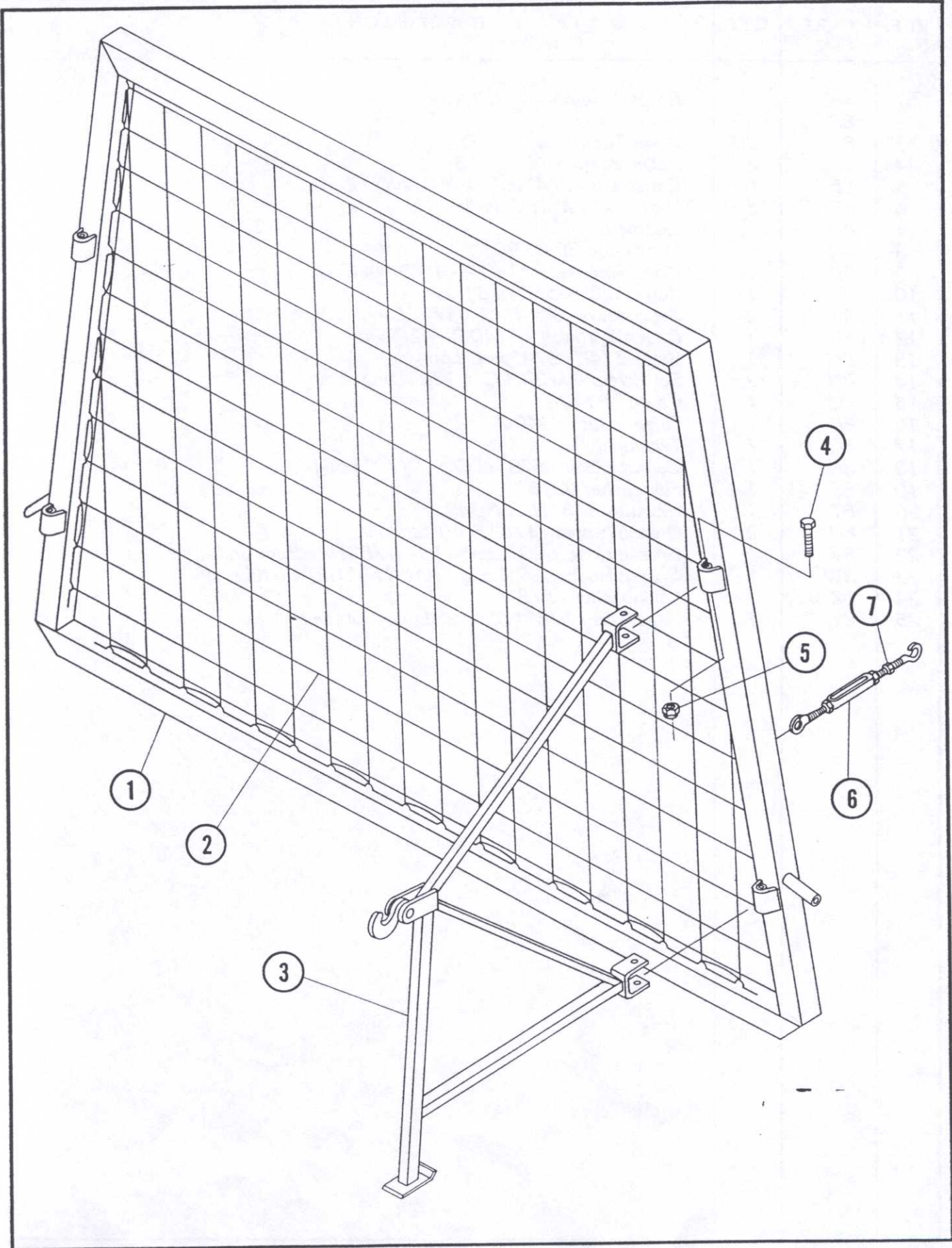

BACKSTOP GROUP



JR-700

REF. NO.	PART NO.	QTY	DESCRIPTION
1	10A	1	Backstop Frame
2	10B	1	Rope
3	10C	2	Side Support
4	10D	4	Capscrew - 1/2" N.C. x 4" Long - Grade 5
5	10E	4	Hexnut - 1/2" N.C. Nylok
6	10F	2	Turnbuckle - 1/2"
7	10G	2	Jam Nut - 1/2" N.C.



HYDRAULICS GROUP

JR-700

1540167

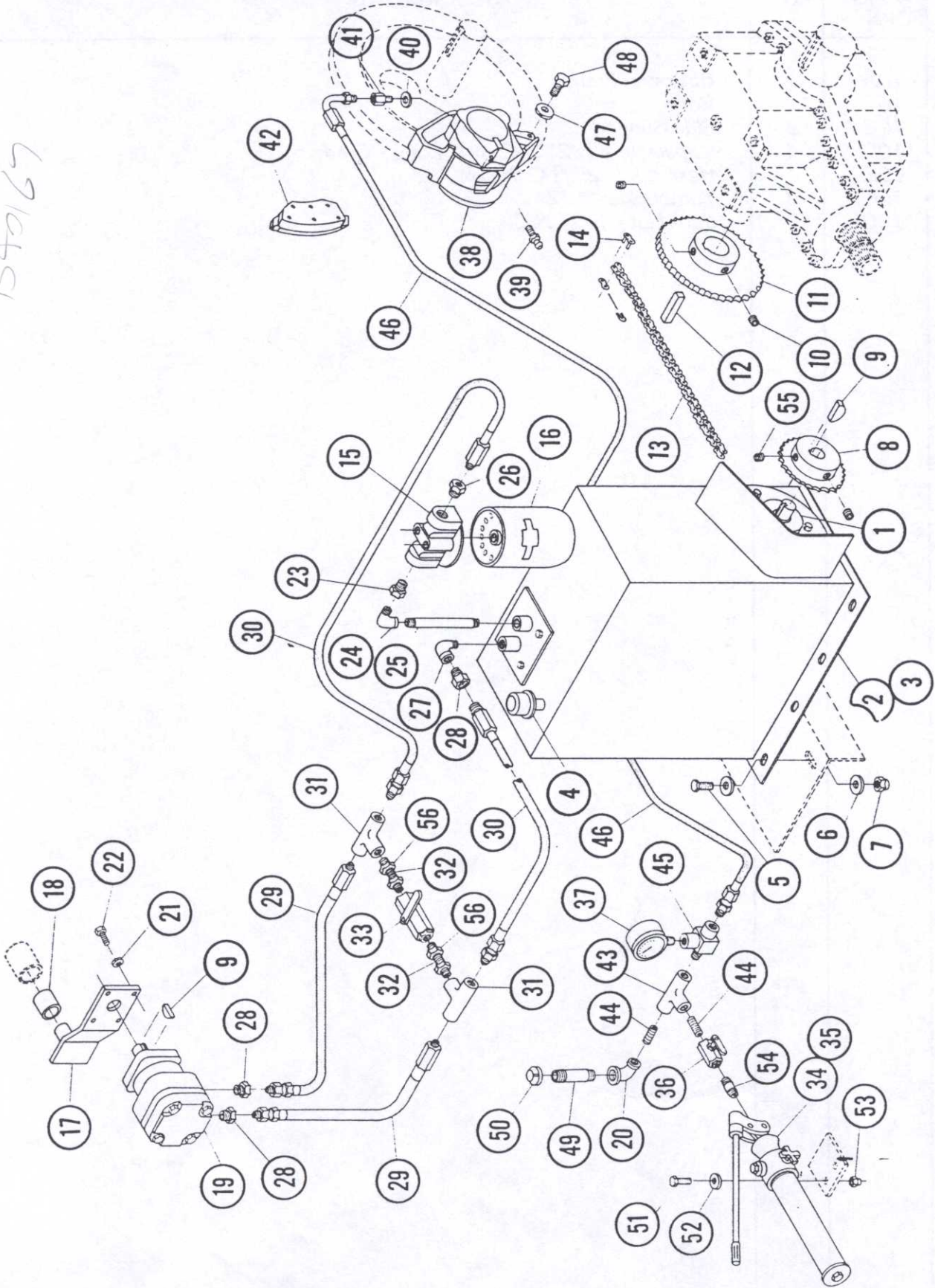

HYDRAULICS GROUP



JR-700

REF. NO.	PART NO.	QTY	DESCRIPTION
1	12A	1	Pump
2	12B	1	Reservoir
3	12C	-	Hydraulic Oil EP-46
4	12D	1	Filler Cap
5	12E	4	Capscrew - 3/8" N.C. x 1 1/4" Long - Grade 5
6	12F	8	Flatwasher - 3/8"
7	12G	4	Hexnut - 3/8" N.C. Nylok
8	12H	1	Driven Sprocket #40-B - 29 Tooth
9	12I	2	Woodruff Key - 1/4" x 1" Long
10	12J	2	Set Screw - 3/8" N.C. x 1/2" Long
11	12K	1	Drive Sprocket #40-B - 48 Tooth
12	12L	1	Key - 3/8" x 3/8" x 1 1/4" Long
13	12M	1	Chain #40
14	12N	1	Connecting Link #40
15	12O	1	Filter Unit
16	12P	1	Filter Cartridge
17	12Q	1	Hydraulic Motor Mount
18	12R	1	Rubber Bushing - 1" ID x 1 1/2" Long
19	12S	1	Hydraulic Motor
20	12T	1	90° Reducing Elbow 1/2" - 1/4" - Sch. 80
21	12U	4	Lockwasher - 3/8"
22	12V	4	Capscrew - 3/8" N.C. x 1" Long - Grade 5
23	12W	1	Reducing Bushing 3/4" - 1/2"
24	12X	1	90° Street Elbow 1/2" NPT - Sch. 40
25	12Y	1	Nipple - 1/2" NPT x 6" Long - Sch. 40
26	12Z	1	Reducing Bushing 3/4" - 3/8"
27	12ZA	1	90° Street Elbow - 1/2" NPT - Sch. 80
28	12ZB	3	Reducing Bushing 1/2" - 3/8"
29	12ZC	2	Hose 3/8" x 12" Long
30	12ZD	2	Hose 3/8" x 48" Long
31	12ZE	2	Hydraulic Straight Tee - 3/8" NPT
32	12ZF	2	Close Nipple - 1/4" NPT
33	12ZG	1	Ball Valve - 1/4" - 2,000 Lb.
34	12ZH	1	Hand Pump
35	12ZI	-	Hydraulic Jack Oil ONLY
36	12ZJ	1	Ball Valve - 1/4" - 2,000 Lb.
37	12ZK	1	Gauge - 0-1,500 Lb.
38	12ZL	1	Disc Brake Caliper
39	12ZM	1	Bleeder Valve
40	12ZN	1	Copper Washer
41	12ZO	1	Adapter
42	12ZP	1	Disc Brake Pad Set
43	12ZQ	1	Hydraulic Straight Tee - 1/4" NPT
44	12ZR	2	Close Nipple - 1/4" NPT
45	12ZS	1	Service Tee - 1/4" NPT
46	12ZT	1	Hose - 1/4" x 11' Long
47	12ZU	2	Lockwasher - 1/2"
48	12ZV	2	Capscrew - 1/2" N.C. x 1" Long - Grade 5
49	12ZW	1	Nipple - 1/2" NPT x 4" Long - Sch. 80
50	12ZX	1	Pipe Cap - 1/2" FNPT - Sch. 80
51	12ZY	2	Capscrew - 1/4" N.C. x 1" Long - Grade 5
52	12ZZ	2	Flatwasher - 1/4"
53	12ZZA	2	Hexnut - 1/4" N.C. Nylok
54	12ZZB	1	Nipple - 1/4" NPT x 1 1/2" Long
55	12ZZC	2	Set Screw - 5/16" N.C. x 3/8" Long
56	12ZZD	4	Reducing Bushing 3/8" - 1/4"



CROSS CONVEYOR GROUP

JR-700

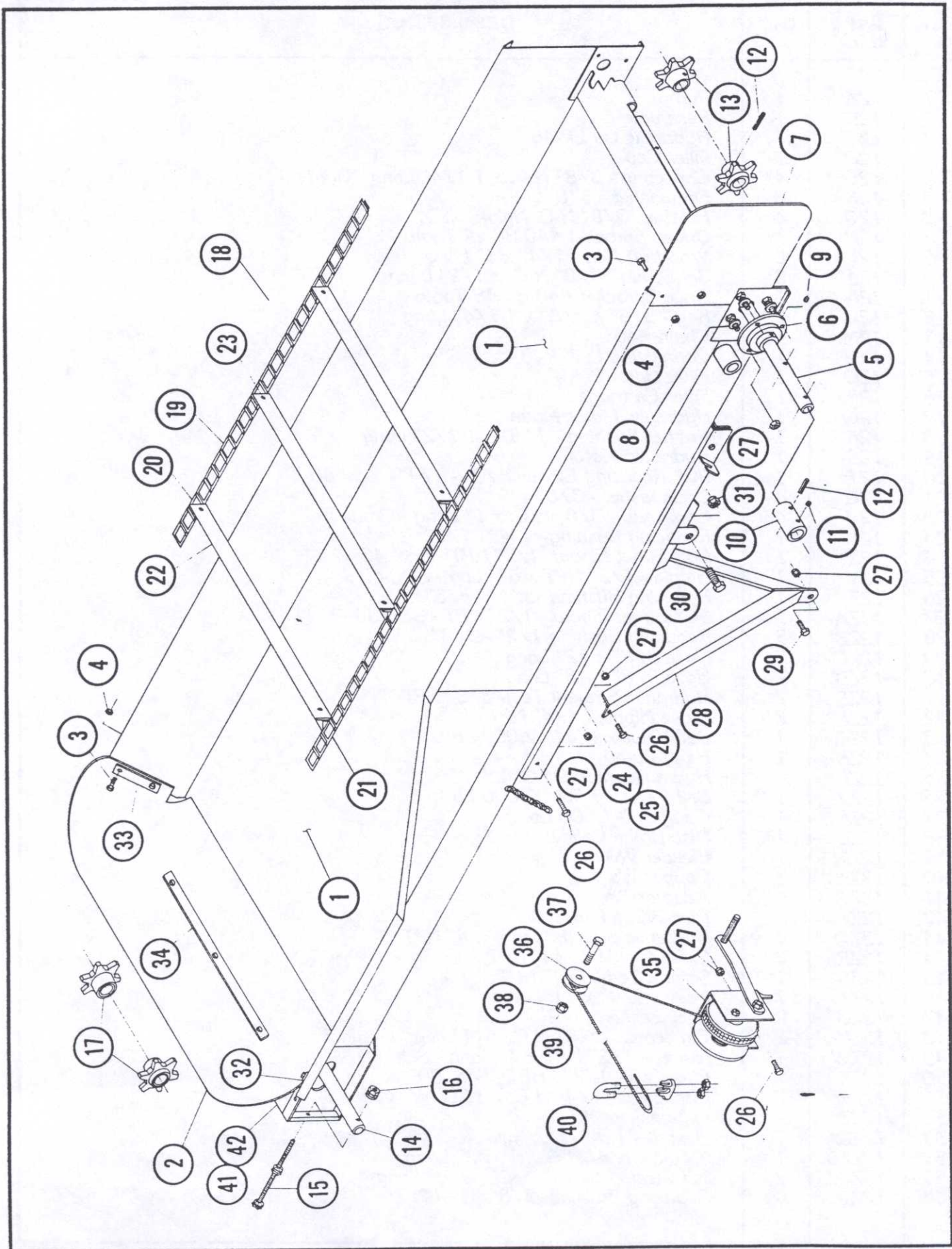



MISCELLANEOUS GROUP

JR-700

BAG-BAG JR-700 BAGGER

BAG-BAG CORPORATION

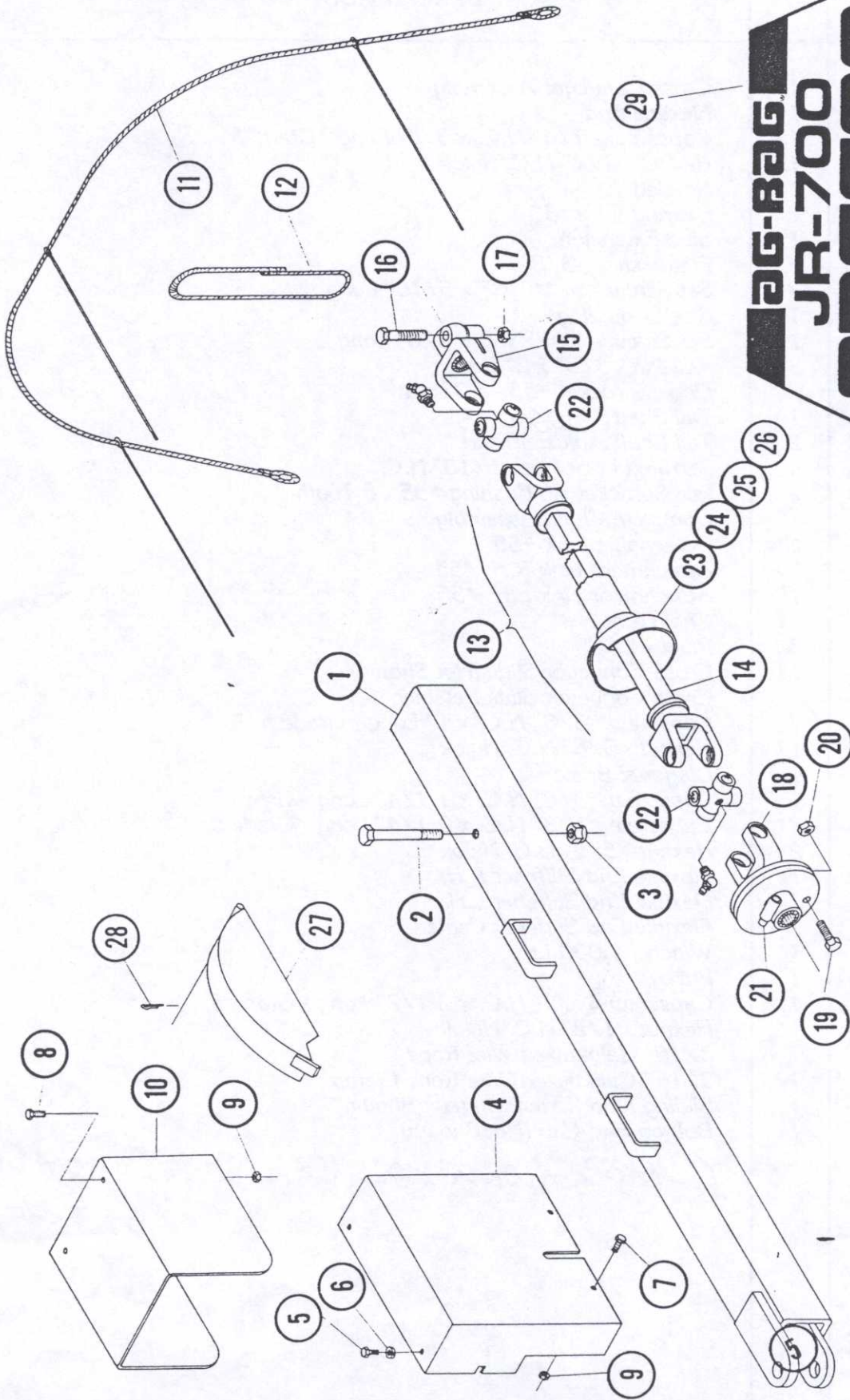

MISCELLANEOUS GROUP



JR-700

REF. NO.	PART NO.	QTY	DESCRIPTION
1	16A	1	Field Hitch Assembly
2	16B	1	Capscrew - 5/8" N.C. x 5 1/2" Long - Grade 5
3	16C	1	Hexnut - 5/8" N.C. Nylok
4	16D	1	Chain Guard
5	16E	2	Self-Tap Screw - 1/4" N.C. x 1" Long
6	16F	2	Lockwasher - 1/4"
7	16G	2	Capscrew - 1/4" N.C. x 3/4" Long - Grade 5
8	16H	2	Capscrew - 1/4" N.C. x 1 1/4" Long - Grade 5
9	16I	4	Hexnut - 1/4" N.C. Nylok
10	16J	1	P.T.O. Guard
11	16K	1	Bag Support Bungee Cord Assembly
12	16L	2	Bag Pan Support Bungee Cord Assembly
13	16M	1	P.T.O. Shaft - Complete 1500854
14	16N	1	Shafts and Yokes Assembly
15	16O	1	Implement Yoke 27 Spline
16	16P	1	Capscrew - 5/8" N.C. x 3" Long - Grade 5
17	16Q	1	Hexnut 5/8" Nylok
18	16R	1	Snap Hitch Yoke - Tractor End
19	16S	1	Capscrew - 7/16" N.C. x 1 3/8" Long - Grade 2
20	16T	1	Hexnut - 7/16" N.C.
21	16U	1	Snap Hitch Pin Repair Kit 02010221 SYMIX 1500210
22	16V	2	Complete Cross Kit - Includes Lube Fitting
23	16W	1	Plastic Shield
24	16X	2	Nylon Bearing
25	16Y	2	Thrust Washer (Not Shown)
26	16Z	2	Snap Ring (Not Shown)
27	16ZA	1	Brake Rotor Guard
28	16ZB	1	Cotter Pin
29	16ZC	1	Decals - Complete Set

160 - WE STOCK B & P
 MOST SHAFTS USE G & G
 SO SHIP DIRECT - NOT FROM INVENTORY.