

T8088 Ag-Bagger

Operator and Parts Manual

(For Repair Parts, see Page 95)

Includes installation, operating, adjustment, maintenance, technical, repair parts and safety information for the T8088 Ag-Bagger



Please retain this document for future reference.

A Color PDF copy of this document is available online for download.



bit.ly/OperManual

Ag-Bag by RCI
RCI Engineering
www.ag-bag.com

Copyright © 2024 by RCI Engineering LLC
AB3172155 Rev A (22Apr24)



1 WARRANTY STATEMENT

Ag-Bag by RCI New Agricultural Equipment

Ag-Bag by RCI, LLC, hereinafter referred to as Ag-Bag, warrants new Ag-Bag by RCI Equipment, to the Original Retail Purchaser to be free from defects in material and workmanship for a period of one (1) year from the date of sale.

Ag-Bag by RCI warranty includes:

Genuine Ag-Bag by RCI parts costs and labor required to repair or replace equipment at the selling dealer's business location.

AG-BAG BY RCI MAKES NO REPRESENTATIONS OR WARRANTIES OF ANY KIND, EXPRESSED OR IMPLIED (INCLUDING THE IMPLIED WARRANTIES OF MERCHANTABILITY AND FITNESS FOR PARTICULAR PURPOSE), EXCEPT AS EXPRESSLY STATED IN THIS WARRANTY STATEMENT.

AG-BAG BY RCI WARRANTY **DOES NOT** INCLUDE:

1. Transportation to the selling dealer's business location or, at the option of the Original Retail Purchaser, the cost of a service call.
2. Freight costs above standard shipping costs for the replacement parts.
3. Used equipment.
4. Components covered by their own non-Ag-Bag warranties, such as tires and trade accessories.
5. Normal maintenance service and expendable, high-wear items.
6. Sacrificial components designed to fail to prevent damage to other components when obstructions are encountered (i.e., shear bolts, rotor teeth)
7. Repairs or adjustments caused by improper use; non-intended use; failure to follow recommended maintenance procedures; use of unauthorized attachments; accident or other casualty.
8. Liability for incidental or consequential damages of any type, including, but not limited to lost profits or expenses of acquiring replacement equipment or damage to machines to which the attachment is installed.

No agent, employee, or representative of Ag-Bag by RCI has any authority to bind Ag-Bag by RCI to any warranty except as specifically set forth herein. Any of these limitations excluded by local law shall be deemed deleted from this warranty; all other terms will continue to apply.

THIS PAGE INTENTIONALLY LEFT BLANK





Product Specifications

FEATURE	T8088
DRIVE	
Driveline	1000-RPM Planetary Driveline
Drive Chain	Double 120 Roller Chain
Rotor Width	104-inches
Number of Rotor Teeth	156
Rows of Rotor Teeth	3 - Revolutionary
Rotor Bearings (Both Sides)	Footed Spherical 3-7/16"
Jackshaft Size and Bearings (Both)	Footed Spherical 3-7/16"
CONVEYOR	
Single Wide Chain Conveyor with CA550 Chain	Standard
Hydraulic Conveyor Lift	Standard
HYDRAULICS	
Self-Contained Hydraulics	Standard
External Reservoir	Standard
Hydraulic Jack System	Standard
COMPACTION SYSTEM	
Anchor Positioning System	Standard - Two adjustable steel anchors
Anchor Travel Distance	0' to 6' - Infinite Adjustment
Wheel Brakes	Standard - Hyd Disc Brake
Brake Hand Pump	Standard
Maximum Ag-Bag Length	500'
TUNNELS AND EXTENSIONS	
10' Tunnel Top	Yes - Interchangeable
12' Tunnel Top	Yes - Interchangeable
10' x 40" Tunnel Extension	Standard with 10' Tunnel Top
12' x 40" Tunnel Extension	Standard with 12' Tunnel Top
Sweeping Tunnel Cleanout	Standard
BAG BOOM AND CRADLE	
Bag Boom with Brake Style Winch	Standard
Bag Cradle with Tunnel Lift Capability	Standard
INOCULANT APPLICATION	
Dry or Liquid	Optional
SPECIFICATIONS	
Overall Width (Transport)	8' 6"
Overall Width (Ag-Bagging)	18'
Overall Length (Transport)	22'
Overall Length (Ag-Bagging) (approx)	13' w/o Ext, 16' 4" w/ Std Ext
Overall Transport Height (for farm)	12' 6"
Overall Transport Height (from factory)	10' 6"
Overall Weight (w/12' Tunnel, approx)	13,500 lbs
Tongue Weight (w/12' Tunnel, approx)	1,800 lbs (Transport)
Horsepower Minimum	150 hp
Horsepower Maximum	220 hp

4 SAFE OPERATION OF MACHINE

Operator Authorization

The machine owner must provide the operator of the machine this manual and ensure that the operator reads and understands the contents. This must be performed before the machine is put into operation.

Safety Alert Symbol



This safety alert symbol is used to alert the operator to the potential for personal injury. Whenever this symbol is noticed in this manual or on the machine, be alert to the situation and read the message near the symbol. Always be alert for the potential for personal injury.

General Safety Precautions / Accident Prevention

Before operation of the machine each time, check the entire machine for operational and road safety. Refer to the Operator Manual for the Tractor for all information regarding the Tractor. This manual is for the Ag-Bagger and only covers items related to the operation of the Ag-Bagger.

1. The warning and safety decals on the Ag-Bagger provide important information to ensure safe operation of the machine. Always read and follow these instructions and remain safe.
2. Familiarize yourself with all controls of the machine and tractor as well as the function of the unit before operation of the Ag-Bagger.
3. Check all guards and shields to make sure they are in place and functional. Replace any defective or missing guards, shields, or components before operation.
4. Avoid loose fitting clothing. The operator should always wear close-fitting clothing and sturdy footwear.
5. When traveling on public roads or transporting the machine, obey all regulations for the area. See the *Transporting the Ag-Bagger* section for more information on proper machine setup for transportation.
6. Before starting the tractor each time, the machine is operated, inspect the area around the machine. Ensure that no one is by the machine for bystander safety.
7. Keep clear of the working and danger area of the machine.
8. Use caution when working on moveable components of the machine. There are many pinch and shear points.



General Safety Precautions / Accident Prevention Continued

9. Know how to stop Ag-Bagger operation BEFORE starting the machine.
10. DO NOT enter the conveyor or hopper while the machine is operating or any time the PTO is still connected to the tractor or before following the Power Shut Down Procedure on the next page.
11. DO NOT unclog, adjust, lubricate or service your Ag-Bagger until following the Power Shut Down Procedure on the next page.
12. Do not allow any riders on the machine nor step onto the machine during use.
13. Avoid high pressure fluids. Escaping fluid under pressure can penetrate skin causing serious injury.
14. Wear appropriate eye and hearing protection for the equipment being used.
15. DO NOT exceed a maximum towing speed of 25 mph (40 kph) while transporting the Ag-Bagger.
16. Reduce speed on rough or hilly surfaces.
17. Be extra careful when passing through tight areas such as farmyards, fence gates, or other confined quarters.
18. Always follow state and local regulations regarding use of the included safety chain, slow moving vehicle signs and transport lighting when towing any farm equipment on public highways.
19. Only operate the Ag-Bagger on solid, level ground.
20. Be sure the tractor is in NEUTRAL, and the parking brake released, before beginning any Ag-Bagging operation after the Ag-Bagger is set up for Ag-Bagging.
21. Be sure the tractor wheels are pointed in a straight-ahead position while Ag-Bagging.
22. Do not turn the tractor and Ag-Bagger while Ag-Bagging.
23. Be sure the hitch jack locking pin is completely engaged and that the machine is properly blocked and prevented from rolling BEFORE disconnecting the Ag-Bagger from the tractor.



24. DO NOT stand between the tractor and Ag-Bagger when hitching or unhitching Ag-Bagger unless engine is stopped, and parking brake is engaged.
25. ALWAYS STAY CLEAR of brakes, cables and cylinder. Cables are under tension during Ag-Bagging Operations. A fast release of tension could have unexpected consequences including movement of the machine forward.
26. ALWAYS stop Ag-Bagging operation and shut tractor off between loads if Ag-Bagger is to be left unattended.
27. NEVER use a PTO Spline Adapter. Failure to follow this precaution may result in machine damage, severe injury, or death. Use of an adapter will void warranty for the Ag-Bagger due to high potential for damage to the tractor PTO, PTO driveshaft or other Ag-Bagger components.
28. ALWAYS match the right tractor PTO spline and speed with the PTO driveshaft provided with the implement. This will assure proper geometry and operating speed.
29. NEVER cross over the top of the PTO shaft. NEVER touch the PTO shaft when the tractor is running. Failure to follow this precaution may result in severe injury or death.
30. NEVER operate 540 rpm implements at 1,000 rpm.
31. NEVER operate 1,000 rpm implements at 540 rpm.

Power Shut Down Procedure

Before cleaning, unclogging, adjusting, lubricating, or servicing this Ag-Bagger:

1. Disengage the tractor PTO.
2. Deactivate hydraulic controls.
3. Shut off the tractor engine, remove the ignition key, and take it with you.
4. Wait for all machine motion to stop.
5. Remove the telescoping PTO driveline and ALL power connections from the tractor.

WARNING: Failure to follow these precautions may result in serious injury or death.

5 SAFETY WARNING SIGNS

Safety Messages

Whenever the words and symbols shown below are used in this manual or on the machine, the instructions **MUST** be followed as they relate to personal safety.



Safety Decal (1). Manual Reference. Before operating the machine, make sure to read this manual in it's entirety.



Safety Decal (2). This safety sign is a warning of missing shields, covers, or other components. Keep clear of this area and replace the missing components before operation. Consult the operator manual and parts pages to determine what components are missing and replace accordingly. Failure to do so may result in serious injury.



Safety Decal (3). Rotating parts hazard. This safety decal is a warning of moving and rotating parts. Keep all body parts and clothing a safe distance from the machine during operation. Shut off the machine before performing any service on the machine.



Safety Decal (4). Rotating and moving parts hazard. This safety decal is a warning of moving and rotating parts. Keep all body parts and clothing a safe distance from the machine during operation. Do not stand on components. Shut off the machine before performing any service on the machine.



Safety Decal (5). Entanglement hazard. This safety decal is a warning of rotating parts that may cause entanglement. Keep all body parts and clothing a safe distance from the machine during operation. Shut off the machine before performing any service on the machine.



Safety Decal (6). Auger or rotor entanglement hazard. This safety decal is a warning of rotating parts that may cause entanglement. Shut off the machine before performing any service on the machine in this area.



Safety Decal (7). This safety sign is a warning of injury due to high temperature surface. Keep away from this area when the machine is in use or has been used recently to avoid the hazard. Failure to do so may result in serious injury.



Safety Decal (8). This safety sign is a warning of injury due to escaping hydraulic fluid under pressure. Keep away from this area when the hoses have hydraulic pressure to avoid the hazard. Failure to do so may result in serious injury.



Safety Decal (9). This safety sign is a warning that the surface is not to be used as a step. To avoid the hazard, do not step on the surface. Failure to do so may result in serious injury.



Safety Decal (10). This safety sign is a warning of injury due to a pinch or shear point. Keep feet clear of this area to avoid the hazard. Failure to do so may result in serious injury.



Safety Decal (11). This safety sign is a warning to NOT tow the implement over 25 MPH (40 kph). Keep towing speeds under this speed to avoid the hazard. Failure to do so may result in serious injury.



Safety Decal (12). This safety sign is a warning to keep the PTO speed at the rated speed of 540 RPM or 1000 RPM. Do not overspeed the implement to avoid the hazard. Failure to do so may result in serious injury and / or machine damage.



Safety Decal (13). Pinch Point. This safety sign is a warning of a pinch point that can cause injury if encountered, especially during machine movement. Keep away from this area when the machine is in use. Shut off the machine before performing any service on the machine in this area.



SMV - Slow Moving Vehicle Decal (14). This SMV decal must be visible on the back of the machine during road transport. See local DOT regulations for details.



Optimum Crop Flow Reminder. Located above the rotor in the hopper. See *the Performance Optimization* section of this manual for more information.

6 SAFETY SIGN LOCATIONS

Machine Decals

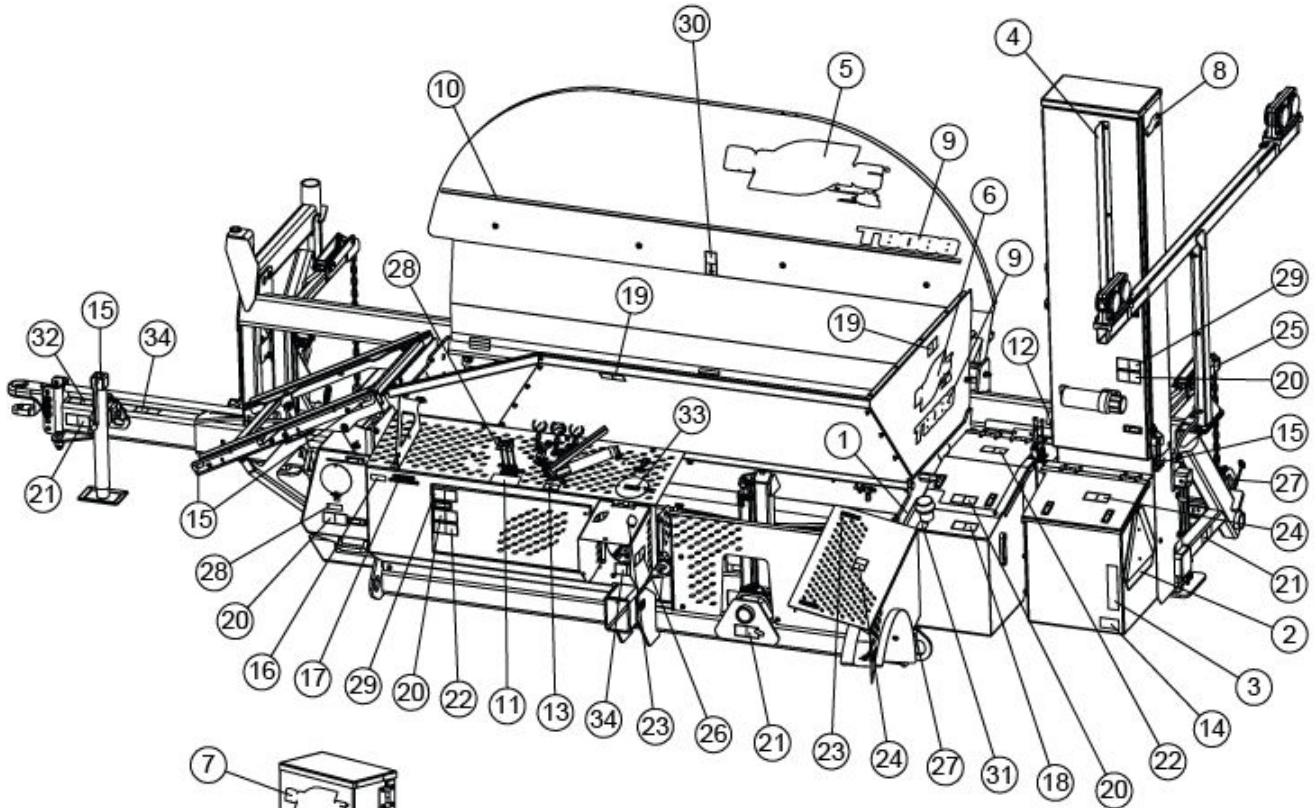

AB3171677 - T8088 Decal Kit

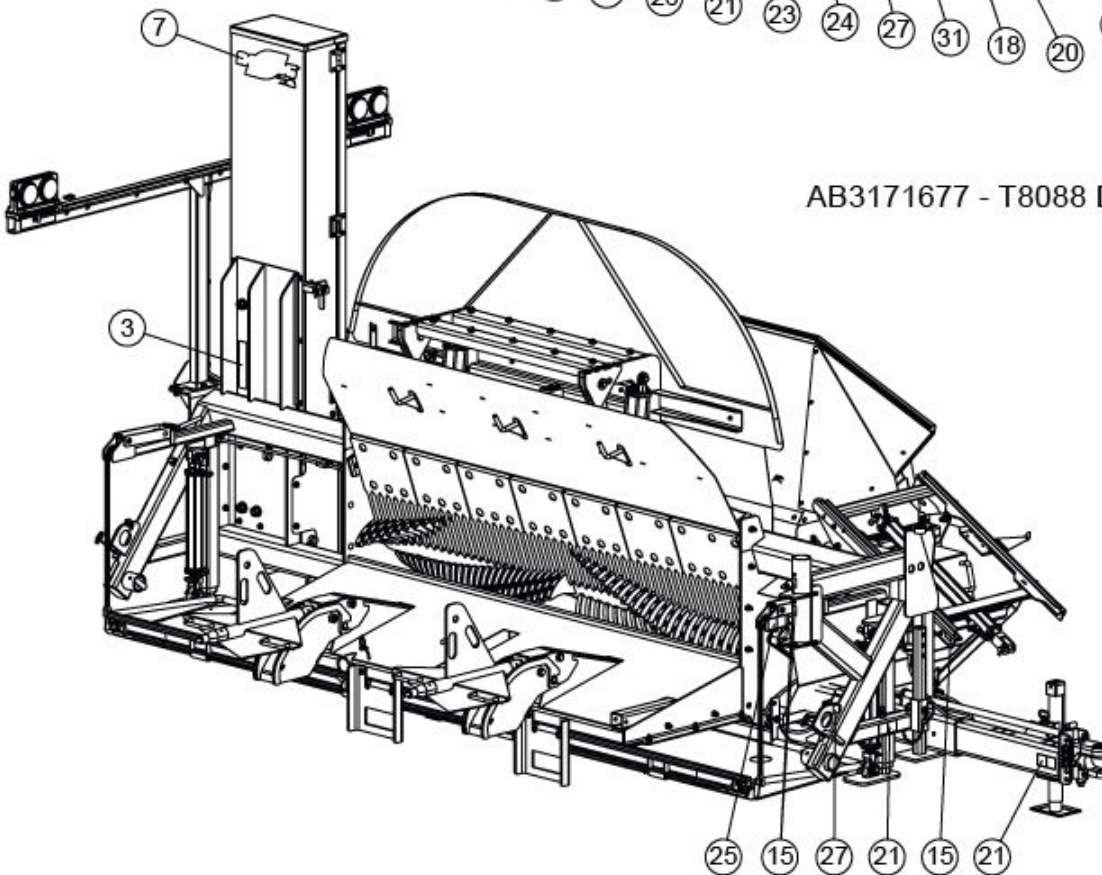

Key	Safety Decal	Description	Qty
1		Tag, AB317 Serial Number	1
2		Sign, Plastic SMV	1
3		Reflector, Yellow 2 x 9	2
4		Decal, Anchor Position	1
5		Decal, 12" x 32" Ag-Bag by RCI Logo	1
6		Decal, 7" x 19" Ag-Bag by RCI Logo	1
7		Decal, 5.9" x 16" Ag-Bag by RCI Logo	1
8		Decal, 2.7" x 7.4" Ag-Bag by RCI Logo	1
9		Decal, T8088 Model Number	2
10		Decal, 104" Double Line	1
11		Decal, 3 Bank Hydraulic Controls	1
12		Decal, Cleanout Door and Machine Lift Controls	1
13		Decal, Ag-Bag Manuals QR Code	1
14		Decal, American Flag	1
15		Decal, Grease	15
16		Decal, Grease Every 2 Hours	1
17		Decal, Horizontal Grease Bank	1
18	7	Decal, Hot Surface Warning	1
19	6	Decal, ISO Auger Entanglement	2
20	3	Decal, ISO Entanglement Hazard	5
21	10	Decal, ISO Foot Crush Hazard	5
22	8	Decal, ISO High Pressure Fluid Hazard	2
23	2	Decal, ISO Keep Safe Distance	6
24	9	Decal, ISO No Step Hazard	2
25	13	Decal, ISO Pinch Point Hazard Horizontal	2
26	5	Decal, ISO PTO Entanglement	2
27		Decal, ISO Tiedown	4
28		Decal, Oil Every 2 Hours	2
29	1	Decal, Read OPM	2
30		Decal, Read OPM Arrow White	1
31		Decal, Universal Trans Oil	1
32	11	Decal, 25 MPH Speed Limit	1
33		Decal, Mobil SHC™ Gear 220 Oil	1
34	12	Decal, 1000 PTO Warning	2

7 COMPONENT LOCATIONS

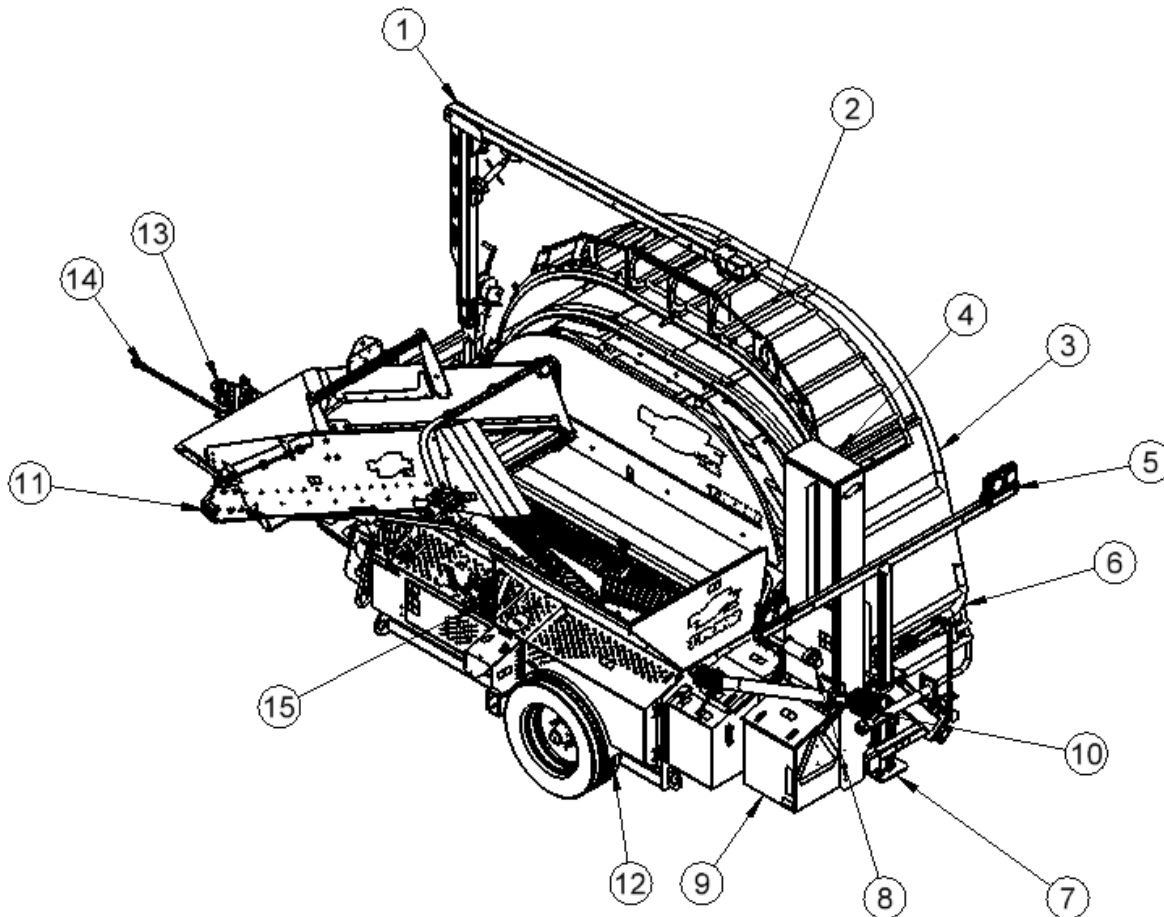

Figure 9. Ag-Bagger Shown in Transport Configuration with Tunnel Extension in Mounted Position (for clarity)

- Key 1 – Bag Boom Key 2 – Bag Cradle Key 3 – Tunnel and Extension
 Key 4 – Anchor Control Key 5 – Taillight Bar Key 6 – Anchors Key 7 – Lift Jack
 Key 8 – OM Holder Key 9 – Storage Compartment Key 10 – PTO Storage Location
 Key 11 – Conveyor Key 12 – Lift Jack Key 13 – Hitch Key 14 – Safety Chain
 Key 15 – Operator Station

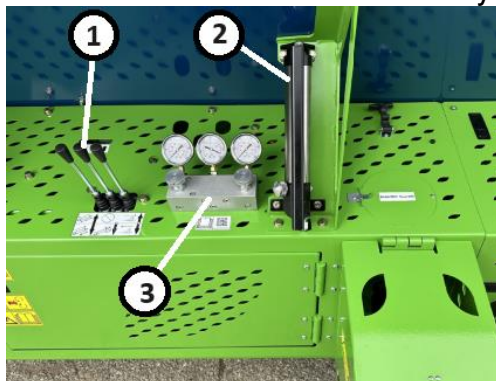

Figure 10. Operator Station
 Key 1–Control Lever Key 2 – Hand Pump
 Key 3 – Brake and Anchor Control



Figure 11. S/N Tag Location (inside compartment)
 Key 1 – S/N Tag

8 Operating the Unit

Pre-Operation Checklist

The pre-operation checklist is provided for both personal safety and maintaining the mechanical condition of the Ag-Bagger.

Make sure each item on the list is checked prior to operating the Ag-Bagger each time.

- Check that the tractor is properly sized to operate the Ag-Bagger. Refer to *Machine Specifications* section.
- Check that the tractor is properly attached to the Ag-Bagger.
- Check that the PTO shaft is properly secured to the Ag-Bagger gearbox input shaft and the tractor PTO shaft.
- Check that the tires are properly inflated and installed properly. See *Tire Air Pressure* in *Lubrication and Maintenance* section for specification.
- Lubricate, grease, and check all fluid levels. Refer to the *Lubrication and Maintenance* section of this manual.
- Check that the grease gun has adequate grease and that a full oil bottle is in the holder at the operator area near the Ag-Bagger controls.
- Check the inoculant applicator (if equipped). Make sure it is properly connected and filled.
- Check all safety shields and guards are closed and secured in place.
- Check the rotor, conveyor, hopper, and tunnel cleanout (if equipped) to ensure there are no foreign objects.
- Check the tunnel cleanout is completely closed.
- Check the conveyor chain for correct tension.
- Check if tunnel extension(s) is (are) properly installed.
- Check each brake disc. Each disc must be clean and rust free. Clean as needed.
- Check the cables to ensure they have no damage and are properly wrapped on the cable drums.
- Check all hydraulic lines, hoses, and fittings for leaks and tightness.
- Check that the bag bungee cord is in good condition and properly installed.
- Check that the bag boom is properly adjusted for height and pulley position. See *Bag Boom* in the *Adjustments* section.
- Check that the hydraulic lift jacks are in the raised position for storage and that the lockout is used. See *Hydraulic Lift Jack Operation* section.
- Check that the machine is clean and free of any debris.
- Check that this Operator Manual is present in the Operator Manual holder on the Ag-Bagger.

Moving Wheels to Ag-Bagging Position and Connecting Tractor

NOTE:

Ag-Bagger must be on a firm, level site to move wheels and hitch.

IMPORTANT:

Site for moving wheels must be level to prevent Ag-Bagger from rolling when unhitched from the towing vehicle. Ground conditions must be firm to prevent lift jacks from settling during wheel removal.

Remove the pin and rotate the lift jack on the tow hitch to the down position. Fasten the lift jack to the hitch in the down position for lifting.

Remove the machine from the towing vehicle. Lower the jack stand to the highest position possible for the current hitch height.

Lower the hitch to rest the machine on the jack stand and remove all pressure on the lift jack.

Remove the lift jack from the hitch.

Remove the cross pin on the hitch and remove the hitch from the machine.

Relocate the hitch to the Ag-Bagging side of the machine and reinstall with cross pin. Handles are provided for ease of moving the hitch.

Install lift jack on hitch and raise to appropriate height for the tractor. See Figures 12 and 13.

Install tractor on Ag-Bagger and install appropriately sized hitch pin. Turn

tractor off, ensure in park, and remove key.

Remove lift jack, rotate 90 degrees and place into transport position on the hitch using cross pin provided.

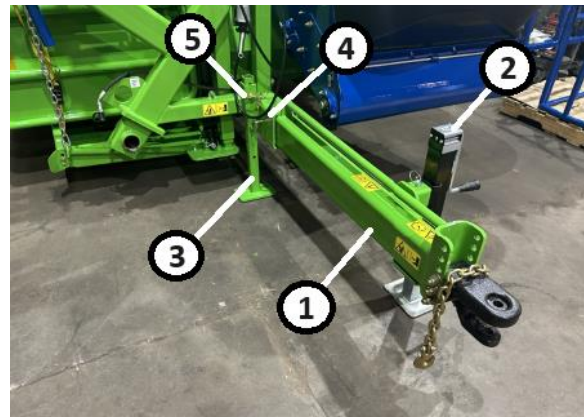

Figure 12. Hitch in Transport Position
Key 1 – Hitch Key 2 – Lift Jack
Key 3 – Jack Stand
Key 4 – Hitch Cross Pin
Key 5 – Jack Stand Cross Pin

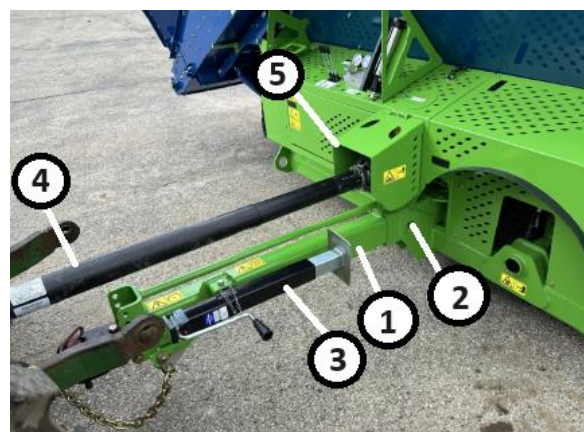

Figure 13. Hitch in Ag-Bagging Position
Key 1 – Hitch Key 2 – Hitch Cross Pin
Key 3 – Lift Jack
Key 4 – PTO Tractor End
Key 5 – PTO Shield

A spare manual jack is located near the storage component.

To use manual lifting, install the lift jack at the towing hitch end wheel lift position. Move the second lift jack from storage position to the wheel lift position at the back side of the machine.

Remove the PTO shaft from the storage position and install between the tractor and the Ag-Bagger.

Push all the way on each shaft and then release the locking collar to lock in place. Ensure that the PTO shaft is locked onto both the gearbox input shaft and the tractor PTO shaft.

Release the rubber latch and lower the PTO shaft guard down to the operating position over the gearbox end of the PTO shaft. Attach the anti-rotation chain of the PTO shield to the slot provided in the cover. Attach the other anti-rotation chain at the tractor end to the tractor as available. See Figure 14.

For manual raising, use the jacks to lift the wheels at the rear from inside the tunnel. One jack is from the hitch and the other is stored at the near the storage compartment. See Figures 15 and 16.

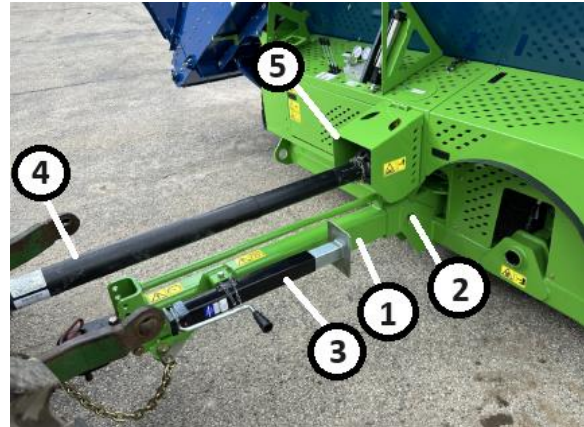

Figure 14. Hitch in Ag-Bagging Position
 Key 1 – Hitch Key 2 – Hitch Cross Pin
 Key 3 – Lift Jack
 Key 4 – PTO Tractor End
 Key 5 – PTO Shield

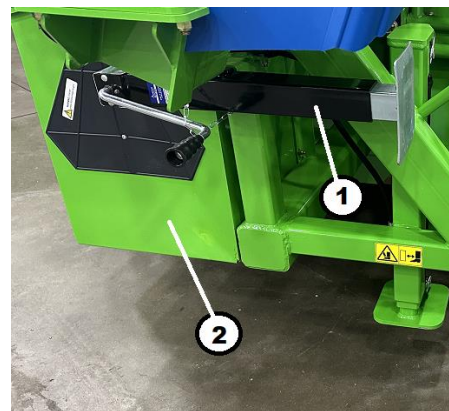

Figure 15. Lift Jack Storage
 Key 1 – Lift Jack
 Key 2 – Storage Compartment (ref)

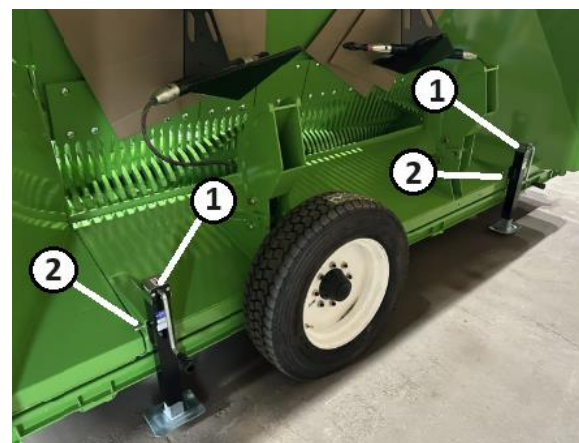

Fig. 16. Lift Jack Usage
 Key 1 – Lift Jack Key 2 – Cross Pin

For hydraulic lifting, first clear the area of bystanders, check that all previous steps are complete, and safely start the tractor and start the PTO at low idle. Keeping the tractor in park and at low idle, go to the controls at the storage compartment and activate the lever for machine lift. See Figure 17.

As the lever is pushed to raise the machine, the lift pads will lower to the ground and then raise the machine. Raise the machine enough to have clearance to remove the front tire.

Return the lever to the neutral position and return to the tractor. Turn off the PTO, shut off the engine, keep the tractor in park and remove the key.

Move the wheel and spindle assemblies from the transport position to the Ag-Bagging position.

Each wheel is held in position with a cross pin with a lynch pin in the end as a retainer. Remove the pins.

Move the wheel and spindle assemblies to the bagging position at the tunnel side of the machine. The tire nearest the hydraulic pump is used at the left end of the tunnel. The tire in the tunnel is used at the right end of the tunnel.

Install the spindle into the tube cross hole and align the hole. Install the cross pin and the lynch pin for a retainer.

Remove the breather at the brake quick coupler, cap it, and put it in the storage compartment. Clean and connect the brake line to the brake. If it will not connect, ensure that the brake pressure is released. Repeat at each end of the machine. See Figures 17 through 20.



Figure 17. Operator Controls
Key 1 – Machine Lift / Lower Lever

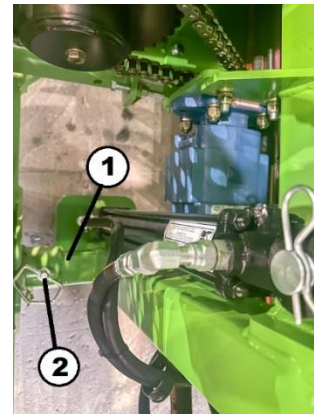

Figure 18. Left Side Spindle Removal
Key 1 – Spindle Assembly Key 2 – Pin

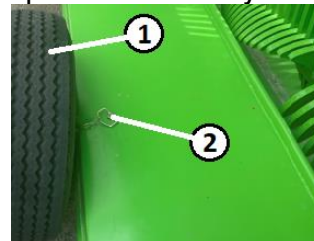

Figure 19. Right Side Spindle Removal
Key 1 – Spindle and Tire Assembly
Key 2 – Pin

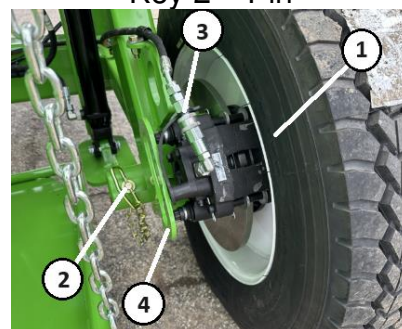

Figure 20. Spindle Install for Ag-Bagging
Key 1 – Tire Key 2 – Cross Pin
Key 3 – Breather + Line Key 4 – Handle

Fully raise the jack stand at the towing hitch end of the machine. Secure the jack stand in the raised position with the cross pin and lynch pin. See Figure 21.

If manual lifting, use the lift jacks to lower the machine down to the ground and remove the pressure from the lift jacks.

Return one jack to the storage location beneath the light bar at the rear of the unit.

Return the other jack to the side of the hitch in a horizontal position. Secure each jack with the attached cross pin. See Figures 22 and 23.

For hydraulic lifting, ensure that all shields are closed on the machine. Clear the area of bystanders. Return to the tractor. Safely start the tractor and start the PTO at low idle while keeping the tractor in park.

Return to the controls near the storage compartment. Activate the lever for machine lowering. The lift arms will raise, and the machine will lower to the ground. Continue raising the lift arms for approximately 10 seconds to ensure they are raised fully to the storage position. Return the lever to neutral. See Figure 17 on previous page.

A lockout valve is located at each hydraulic cylinder to prevent inadvertent movement or cylinder settling. Turn the valve at each of the three hydraulic cylinders to lock out the lift cylinders. See Figure 24.

Return to the tractor. Turn off the PTO, shut off the engine, keep the tractor in park and remove the key.

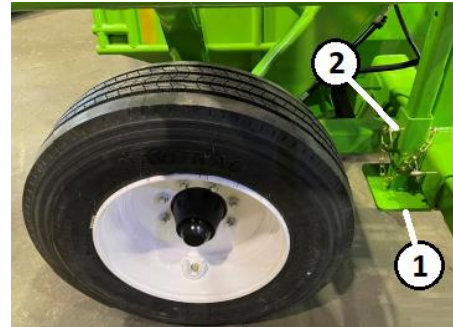

Figure 21. Jack Stand Raising
Key 1 – Jack Stand Key 2 – Cross Pin

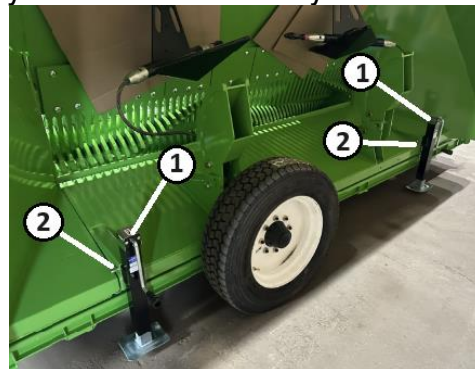

Fig. 22. Lift Jack Usage
Key 1 – Lift Jack Key 2 – Cross Pin



Figure 23. Lift Jack Storage (T7170)
Key 1 – Lift Jack Key 2 – Storage (ref)



Figure 24. Lockout Valve Location
Key 1 – Lockout Valve

Hitch Adjustment

The machine must be adjusted at the hitch to be level or have the tunnel end of the machine lower than the hitch end of the machine.

The tunnel end of the machine should never be higher than level. Failure to do so will result in poor bagging performance.

To adjust the hitch, remove the bolts shown in Figure 25 and move the hitch to the desired height to level the machine.

Reinstall the hitch and tighten hardware properly.

If a tractor with a hammer strap on the hitch is used, the lower portion of the hitch can be removed by removing the bolt. See Figure 26.

The leveling of the machine will result in proper bag formation at the end of the tunnel as shown in Figure 27.



Figure 25. Hitch Adjustment

Key 1 – Hitch Frame

Key 2 - Hitch Key 3 – Bolt

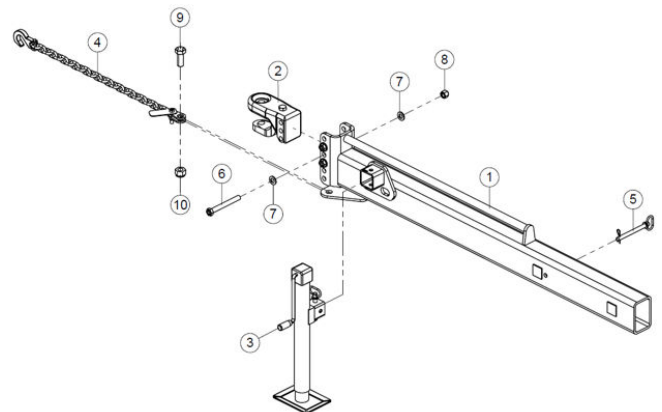

Figure 26. Hitch Parts

Key 6 – Lower Hitch Bolt



Figure 27. Proper Leveling of Unit

Inoculant Applicator Connection

Connect the inoculant applicator electrical supply to a 12-volt source on the tractor.

Consult your local Ag-Bag dealer and the tractor Operator Manual for specific installation and operation instructions.

Bag Boom Adjustment

The bag boom is adjustable for height, handle position and pulley position.

The boom can be adjusted down to rest the tube on top of the bag cradle for transport.

When in use, it can be adjusted to allow for better handling of the bag cradle and tunnel extension.

Typically, higher bag boom positions will allow for easier handling of attachments.

Adjust the turnbuckle to adjust the bag boom. Do not overextend the turnbuckle in adjustment beyond the specification.

SPECIFICATION:

Bag Boom Turnbuckle Maximum Length
(Measured pin-center to pin-center,
Fig.28, Key 2)

31" (78 cm)

The pulley is aligned to the center of the bag cradle when in Ag-Bagging position.

Typically, the pulley will be in the end hole for larger tunnels and the first or second inside

The pulley is adjusted by using the cross pin and selecting a hole.

The handle is also adjustable and serves as a locking device for the bag boom in transport position by locking

into a position on the frame. Use the cross pin at the handle to secure the handle up or down.

Always keep the hook of the cable attached to the machine and the cable tensioned for transport. Secure any loose components to the machine properly in transport.

Be aware of bystanders during operation and adjustment of the bag boom.

IMPORTANT:

1. Do not adjust the bag boom under load.
2. Do not overextend the turnbuckle.
3. Do not climb on machine to adjust the bag boom. With the help of an assistant, safely use a step ladder to access the components.
4. When adjust the turnbuckle, lock the part in place with the locking plate.

Failure to do so may result in machine damage or personal injury.

See Figure 28.

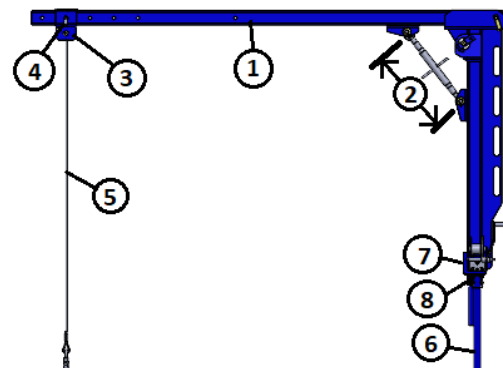

Figure 28. Bag Boom
Key 1–Boom Key 2–Turnbuckle Length
Key 3 – Pulley Key 4 – Pulley Cross Pin
Key 5 – Cable Key 6 – Handle
Key 7 – Winch Key 8 – Handle Pin

Tunnel Extension Installation

The tunnel extension is stored above the main tunnel for transport. This extension is pin-on using pins provided with the machine. It is recommended to use the help of an assistant for this operation.

The bag cradle is used in a raised position to lift the extension from the storage location to be installed on the tunnel base. With the cradle resting on the extension in storage, flip the angles at the bottom over center and under the hook points on the tunnel extension. See Figure 29.

Once flipped, crank the bag boom cable winch to take the weight of the extension. Remove the pins at the storage location. See Figure 30.

Raise the tunnel extension about 6" (150 mm). Swing the bag boom and tunnel around until the tunnel is in the approximate use location.

Starting with a side pin on the extension, adjust the cable winch and boom position until a side pin starts in a hole on the base tunnel.

Next, adjust the extension until the top pin aligns with the hole in the top center. Then pull or push on the remaining side of the tunnel to align the other side pin. Push the extension into position and install the previously removed pins at the base tunnel where the extension is installed. The hitch pin clips are not used at the tunnel extension when installed as they may interfere with the plastic of the bag. Pins are self-retaining with long length to remain installed when in Ag-Bagging position. See Figure 31.

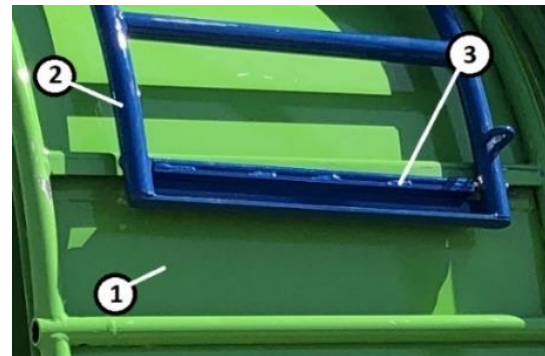

Figure 29. Cradle Hook
Key 1-Ext. Key 2-Cradle Key 3-Hook

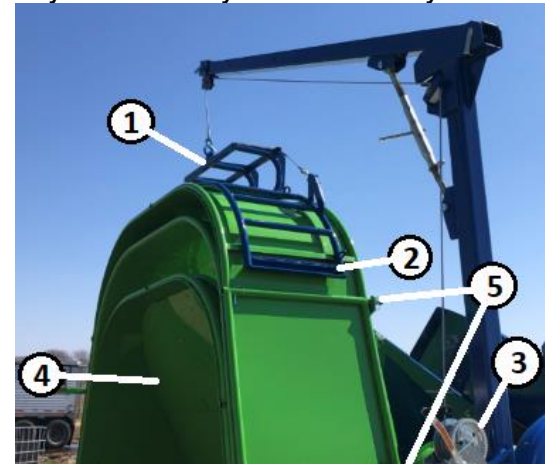

Figure 30. Tunnel Extension Lift
Key 1-Cradle Key 2-Hook
Key 3-Winch
Key 4 - Base Tunnel Key 5 - Pins

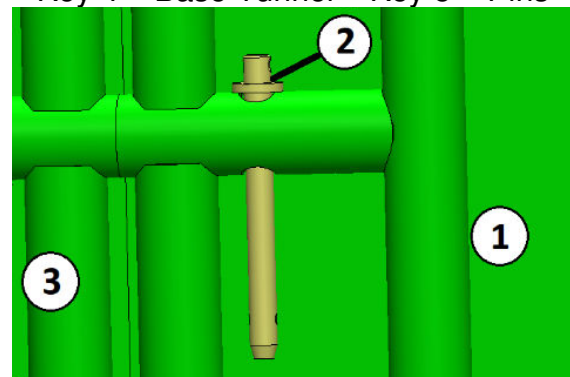

Figure 31. Pin Installation
Key 1-Tunnel Key 2-Pin Key 3-Ext.

Brake Setup

Place the Ag-Bagger where the bag will begin.

Turn off the tractor PTO, put the tractor into park. Shut off engine and remove the key.

Open the needle valves at the gauges.

Never use wrenches as part damage may result.

The lock ring should be loosened first by hand and can be backed off all the way to the knob and turned tight against the knob. It is not needed in this application.

Close the Pump Release at the base of the hand pump. Pump the hand pump to pressurize the brake system to 1750 psi.

The Needle Valves are provided to allow the operator to vary the pressure on each wheel independently if needed.

For example, if one tire is placed on blacktop and the other on soil, they will not hold the same pressure.

At the beginning of the bag, it is important to hold as much backpressure as possible until the bag end is filled. See Figure 32.

Anchor Plate

If bagging on wet ground, or in wet and fine-cut crop conditions, install two anchor plates at each of the anchors as shown in Figure 33. The plates are stored in the storage compartment when not in use. Use the three bolts to install the plates and tighten all hardware properly. See Figure 33.

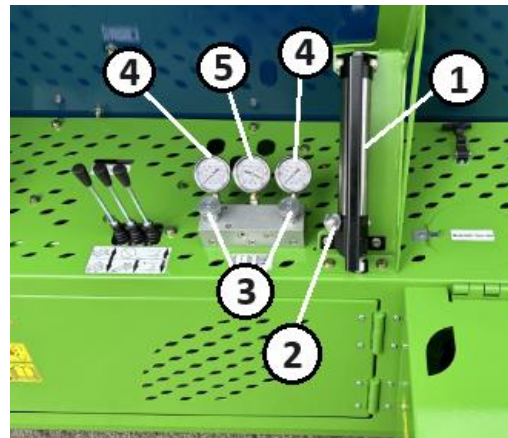

Figure 32. Brake System Control
 Key 1 – Hand Pump
 Key 2 – Pump Release
 Key 3 – Needle Valves and Lock Rings
 Key 4 – Brake Pressure Gauges
 Key 5 – Anchor Cylinder Pressure

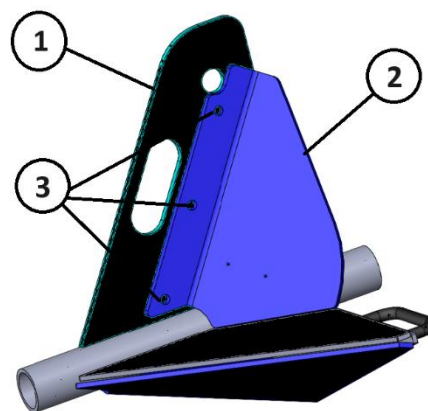

Figure 33. Anchor Plate Installation
 Key 1 – Anchor Key 2 – Anchor Plate
 Key 3 – Hardware Locations
 (anchor plate is shown in blue for reference)

Anchor Setup



WARNING:
NEVER move the anchor position control cylinder or the tunnel cleanout while the anchors are in the storage position or when the tunnel cleanout is open. Machine damage and personal injury may result.

Note: For transport, the anchor position control is typically set to have the anchors set at 3-feet to 6-feet to allow slack in the system for storage for transport.

Make sure the tractor is in park, engine is off and key removed.

At the tunnel side of the machine, remove the lock pins holding the anchor supports and tip them down to bagging position. Reinstall the pins.

Set the anchors off the storage hooks on the ground behind the anchor supports.

Safely start the tractor, slowly engage the PTO, have the engine at low idle, and retract the anchor position control to the zero or “Home” position. This will pull the anchors to the top of the anchor supports.

Once the anchors are drawn to the top of the anchor supports (0 on scale), make sure the tractor is in park, shut off the engine and remove the key.

See Figures 34 through 36. .

Always complete this step before closing the start end of the bag.

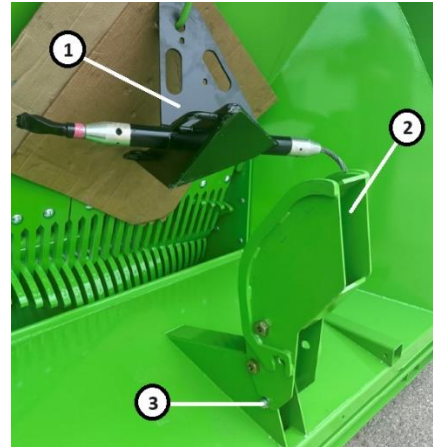

Figure 34. Anchor Storage Position
 Key 1 – Anchor Key 2 – Anchor Support
 Key 3 – Lock Pin

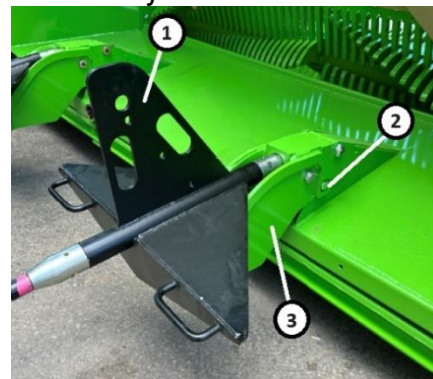

Figure 35. Anchor Bagging Position
 Key 1 – Anchor Key 2 – Lock Pin
 Key 3 – Anchor Support

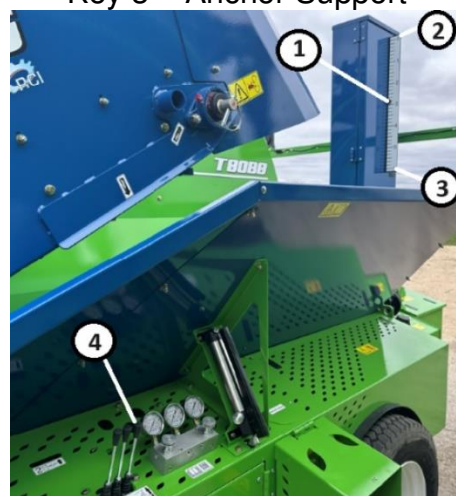

Figure 36. Anchor Position Control
 Key 1 – Indicator Key 2 – Home
 Key 3 – Anchor Out Key 4 –Control

Bag Identification

Only use genuine Ag-Bag bags. They are designed to fit and function properly.

The bag size is indicated on the box. Verify the bag is the correct size for your Ag-Bagger and tunnel.

Locate the arrow on the side of the box. Always make sure it is pointing towards the Ag-Bagger.

IMPORTANT:

Be sure to select the best surface for bag placement. Refer to the *Performance Optimization* section of this manual.

See Figure 37.

Bag Installation

IMPORTANT:

Only use Ag-Bags that are the proper size for your model and tunnel. ALWAYS follow the instructions provided with the Ag-Bag. This section is only provided as a reference of best-practices for installing an Ag-Bag. ALWAYS take care to prevent damage to the Ag-Bag.

Lower the bag pan by unhooking the lock pin of the lift lever at each side of the tunnel. Lift the lever to lower the chain and bag pan to rest on the ground. See Figure 38.

Open the gate of the bag pan by removing the lynch pin and pulling the spring-loaded pin to free the gate. Rotate the pin to retain it in retracted position. Repeat on opposite side. See Figure 39.



Figure 37. Ag-Bag Identification
Key 1 – Ag-Bag Size Key 2 - Direction

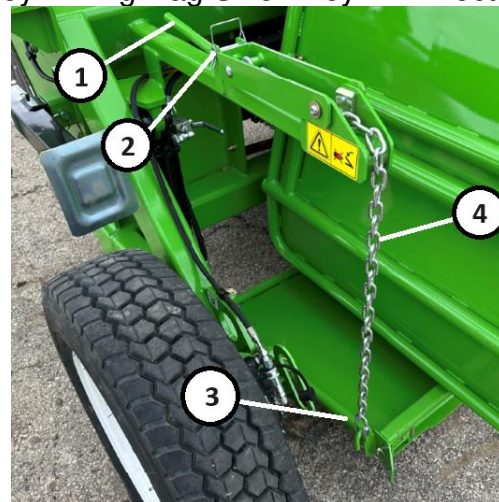

Figure 38. Bag Pan
Key 1 – Lift Lever Key 2 – Lock Pin
Key 3 – Bag Pan Key 4 – Chain

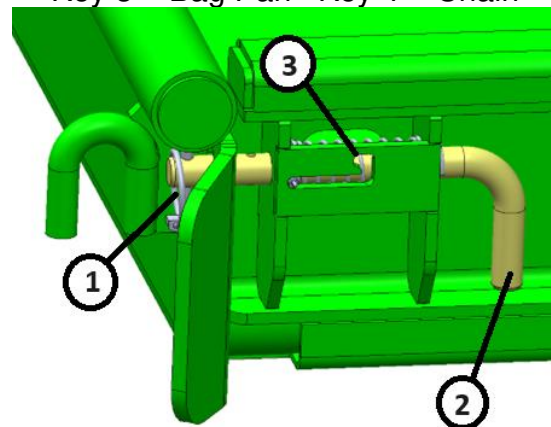

Figure 39. Bag Pan Gate
Key 1 – Lynch Pin Key 2 – Pin
Key 3 – Retention Slot

Using the winch on the bag boom, lower the bag cradle to the ground fully.

See Figure 40.

Align the Ag-Bag box with the back of the tunnel such that the arrow on the box is pointing towards the tunnel.

Cut the plastic bands from the box and remove the outer lid. See Figure 41.

DO NOT remove the ties around the Ag-Bag until the Ag-Bag is on the tunnel. Remove the inner shell and the box will flatten.

Unfold the bag. Lift the top half of the bag and place it on the bag cradle. Use the winch on the bag boom to raise the Ag-Bag and cradle.

See Figure 42.



Figure 40. Cradle Lowered to Ground



Figure 41. Ag-Bag Box
 Key 1 – Arrow Location
 Key 2 – Plastic Bands
 Key 3 - Lid



Figure 42. Bag Installation on Cradle

Remove the top three strings over the bag at the top by the bag cradle. This will allow for the other strings to be reached from the ground once the Ag-Bag is installed on the tunnel.

Place the Ag-Bag bungee cord over the bag on the cradle and fasten the 4 retaining ropes to the hoops on the cradle such that the bungee cord will rest to the rear of the Ag-Bag when bagging. See Figure 43.

Crank the bag boom winch up until the cradle is above the tunnel. Carefully work the Ag-Bag around the tunnel, making sure the bag maintains its flat appearance and is flat between the tunnel and the bag pan.

Lower the cradle until it is resting on top of the tunnel. The cradle must rest on the tunnel and not on the tunnel extension.

The cradle must rest between the pipes on the top of the tunnel. See Figure 44.

Once the cradle is in place and the Ag-Bag is aligned, remove all the remaining ties that hold the Ag-Bag folds together.

Start to pull the plastic all around the tunnel approximately 36". Install the bungee cords supplied with the Ag-Bagger.

NOTE:

DO NOT roll the Ag-Bag while placing on the tunnel. Keep the folds flat. Ag-Bag damage may occur when Ag-Bagging if the Ag-Bag is not flat.

CAUTION:

Caution should be used when moving Ag-Bags. Weight of Ag-Bags can be over 400 pounds (180 kg), depending on size of Ag-Bag.

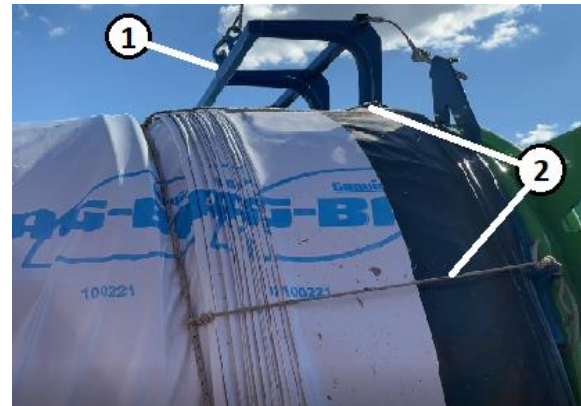

Figure 43. Bungee Retaining String (shown in final position for reference)
Key 1–Bag Cradle Key 2–Strings (2 strings per side of bag cradle)

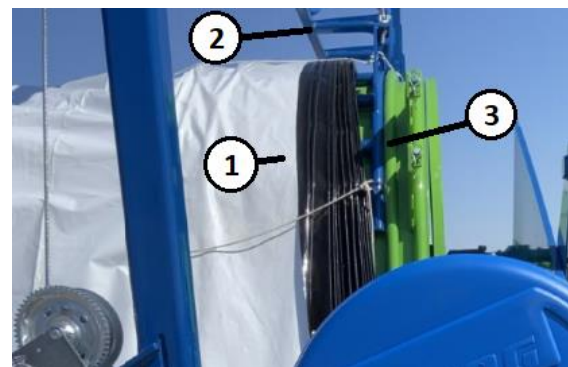

Figure 44. Cradle Rest Position
Key 1 – Bag Key 2 – Bag Cradle
Key 3 – Tunnel Pipes

Close the gate of the bag pan. Install the lynch pins at the pins. Raise the bag pan with the chain and lift lever and secure with the pin. See Figure 46.

Take the ends of the tunnel bungee cord that is tied to the bag cradle and connect to the bag pan hooks on each side of the tunnel.

Check that the tunnel bungee cord support ropes are evenly spaced and aligned parallel to the Ag-Bag.

The purpose of the support ropes is to keep the tunnel bungee cord from following with the bag as the bag is fed off the tunnel.

The bag pan raised position is adjustable using the stop bolts at the hinge point for the bag pan as well as the chain length with the turnbuckle at the lift mechanism.

Measure the bag pan clearance to the tunnel floor. Adjust the stop bolts and turn buckle as needed to achieve the specification. See Fig. 45 through 48.

SPECIFICATION:

Bag Pan Clearance to Tunnel Floor
(Raised position) 3/4 in. (19mm)

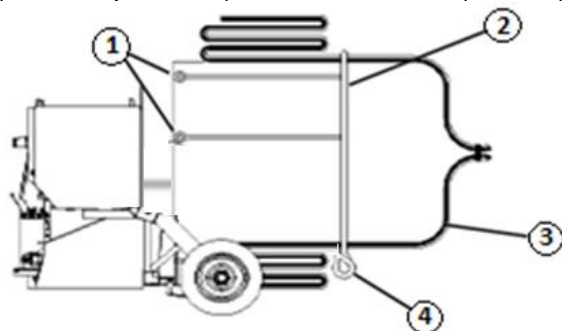

Figure 45. Proper Cord Arrangement
Key 1 – Loops at Bag Cradle
Key 2 – Tunnel Cord Key 3 – Ag-Bag
Key 4 – Bag Bungee Cord

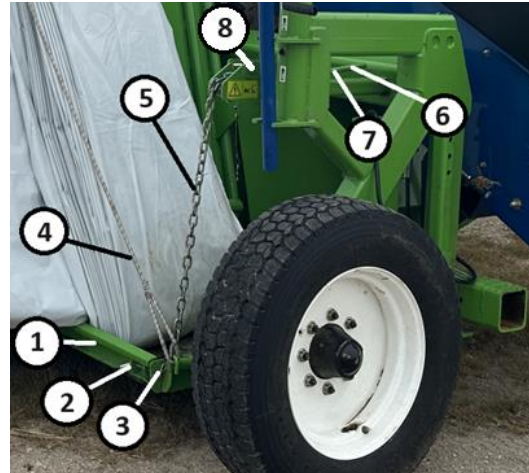

Figure 46. Bag Bungee Cord
Key 1 – Bag Pan Key 2 – Lock Pin
Key 3–Lynch Pin Key 4–Tunnel Cord
Key 5–Chain Key 6–Lever Key 7–Pin
Key 8 – Turn Buckle Location

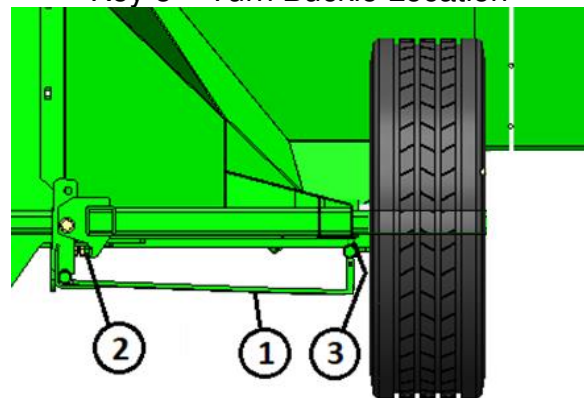

Figure 47. Bag Pan Adjust Location
Key 1 – Bag Pan Key 2 – Adjustment
Key 3 – Specified Gap

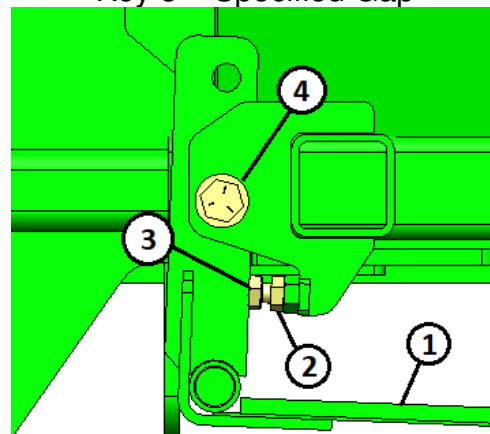

Figure 48. Bag Pan Adjustment
Key 1 – Bag Pan Key 2 – Jam Nut
Key 3 – Stop Bolt Key 4 – Hinge Point

Seal the Beginning End of the Ag-Bag

Pull enough bag to apply the seal. Pull from the inside folds, not the outside folds.

The white surface should be to the outside and the black is to the inside.

Make sure the bag is pulled under the bungee cord.

Seal the end of the bag using one of the two following methods.

A. Master Seal®

Follow the instructions that are included with the Master Seal.

Master Seal and tool are available from your Ag-Bag dealer.

See Figure 49 for part numbers for the Ag-Bag size used.

See Figure 50 for diagram of installation concept.

B. Double-Knot Tie

Find the end of the Ag-Bag gather the ends of the Ag-Bag to the center.

Twist the Ag-Bag and tie it tight.

Leave enough of the Ag-Bag to fold over and tie a second time giving the Ag-Bag an airtight seal.

See Figures 51 and 52.

Slide the excess Ag-Bag back onto the tunnel and bag pan.

Position the knot approximately knee-high.

Part Number	Description
AA1500272	250 ft. Roll
AA1500270	9.5 ft. Long, 4/Box
AA1500267	14.5 ft. Long, 4/box*
AA1500268	17 ft. Long, 4/ Box**
AA1500269	20 ft Long, 4/Box***
AA1500273	Zip Tool

* 9 ft. Ag-Bags

** 10 ft. Ag-Bags

*** 11 and 12 ft. Ag-Bags

Figure 49. Component Part Numbers

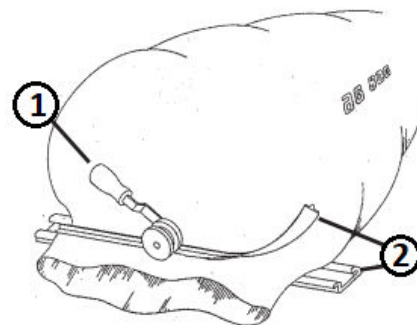

Figure 50. Master Seal Concept
Key 1 – Master Seal Tool
Key 2 – Master Seal

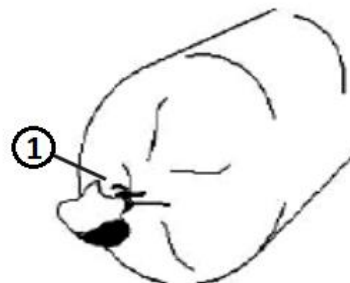

Figure 51. Start of Double-Knot Tie
Key 1 – First Tie

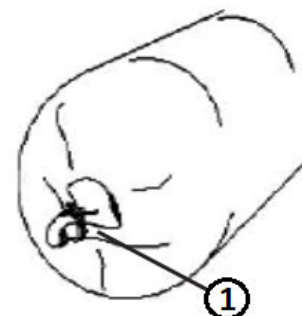

Figure 52. End of Double-Knot Tie
Key 1 – Fold Over and Second Tie

Setting the Bag

IMPORTANT:

Never reverse the tractor with the wheel brakes applied on the Ag-Bagger. Machine damage may result.

The machine should be in position for bagging. There are two ways to set the bag, depending on how the operator desires to place the end knot.

The most-common way is to have the knot be under the bag after bagging, for security reasons.

To do this, pull just enough plastic off the top of the tunnel to bring the knot near the ground. Keep the bottom plastic in the pan as much as possible.

Pull just enough plastic at the bottom so the bottom of the bag can touch the ground. Push any loose plastic in front of the bungee cord. See Figure 53.

The less-common alternative is to have the knot exposed after bagging.

For this alternative, the knot must be at the top of the tunnel and more plastic is pulled at the bottom.

In any case, only pull enough plastic to position the knot as desired and to have the bag reach the ground. Push any plastic not used forward to be in front of the bungee cord.

It is not advisable to have any extra plastic behind the tunnel because it will only create an area of unpacked material at the start of the bag.



Figure 53. Setting the Bag

Lower Conveyor to Operating Position

The tractor PTO must be safely engaged before operating the hydraulic conveyor raise and lower control.

Before lowering the conveyor, release the conveyor lift lock at the upper end of the slide rail. Pull the lock down and rotate to retain the pin in a disengaged condition to release the conveyor lift lock. See Figure 54.

Lower the conveyor down to the operating position by pushing the hydraulic conveyor lift control lever in.

The control lever will return to the centered (neutral) position when released.

Pulling the control lever will raise the conveyor.

The conveyor must NOT rest on the ground when Ag-Bagging. Keep the conveyor approximately six inches off the ground.

The conveyor position must be adjusted such that the discharge material of the conveyor lands directly in the center of the rotor at normal operating speed.

This position can be marked and monitored using the ruler decal at the side of the conveyor.

See *Performance Optimization* section in this manual for more information.

See Figures 55 and 56.



Figure 54. Conveyor Lift Lock
Key 1 – Lock Lever



Figure 55. Conveyor Raise and Lower
Key 1 – Control Lever



Figure 56. Conveyor Position
Key 1 – Ruler Decal Key 2 – Marker

Fold out the conveyor extension to the wide position. Remove the two lynch pins at the hinge joint in the extension.

Move the extension to the outer position and reinstall the pins. See Figure 57.



Figure 57. Conveyor Extension
Key 1 – Lynch Pins Key 2 – Extension

If not installed already, move the conveyor motor from the storage position to the drive position at the conveyor drive shaft.

NOTE:

This motor can be stored at the location above the chain for narrow transport. Do not climb on the conveyor to access the motor. Use a stepladder, or other device, to safely access the motor.

See Figure 58.

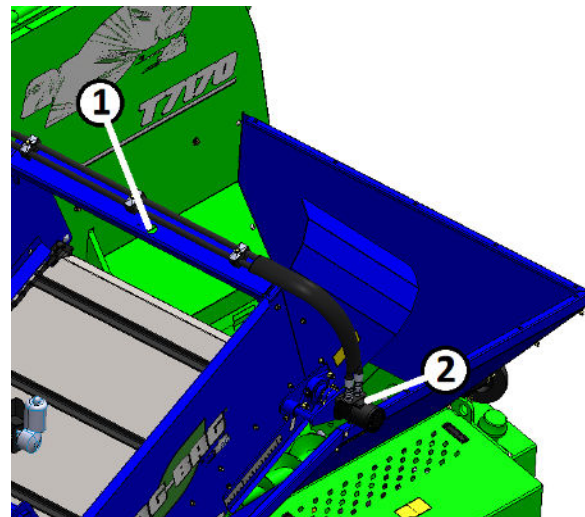

Figure 58. Conveyor Motor Storage
Key 1 – Storage Location
Key 2 – Motor Assembly

Verify Brake Pressure

To start the bag, wheel brake pressure should be maximized for the ground conditions. The maximum pressure of the system is approximately 1950 psi.

IMPORTANT:

If the tires slip on the bagging surface, the pressure for that wheel(s) must be reduced immediately such that the tire will rotate under load without slipping.

IMPORTANT:

If a tire falls into a hole, the bagger may turn until the tire is able to roll out of the hole, no matter which way the tractor is facing. It is important to fill in voids in the bagging surface and to always monitor the tires.

If the tires slip, resistance is immediately lost and it can result in poor performance inside the bag. Here are some estimated pressures for different surfaces:

Clean concrete and blacktop:	1,950 psi
Gravel, hard packed:	1,750 psi
Hard-packed, dry soil:	1,500 psi
Wet soil:	200 psi

If tires are on different types of surfaces, the brakes can be adjusted independently.

If a soft spot, or spillage from the conveyor is encountered at a tire, reduce the brake pressure until the condition is cleared. Keep silage that spills from the conveyor away from the tire.

The pump valve must be closed, and needle valve must be open, to increase brake pressure.

Close the needle valve to hold pressure. Open both valves to release the brake pressure. This pressure is a starting point and may need adjustment depending on crop conditions. See Figure 59.

NOTE:

The braking system uses two accumulators to allow the brake system pressure to be more stable with fluctuations of temperature. Pumping to increase pressure on systems with an accumulator will take more lever pumps to increase the pressure compared to previous models without accumulators. See Figure 60.

See *Performance Optimization* section in this manual for more information.

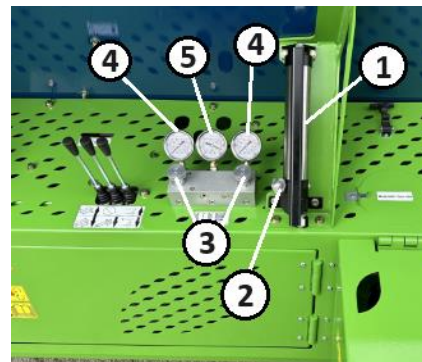

Figure 59. Brake System Control

- Key 1 – Hand Pump
- Key 2 – Pump Release
- Key 3 – Needle Valves and Lock Rings
- Key 4 – Brake Pressure Gauges
- Key 5 – Anchor Cylinder Pressure (ref)



Figure 60. Accumulator Location

- Key 1 – Accumulator (1 of 2)

Verifying Tunnel Cleanout Closed

IMPORTANT:

Always ensure that the cleanout door is closed prior to any Ag-Bagging operation.

The tractor PTO must be safely engaged before operating the tunnel cleanout control.

To close the tunnel cleanout, lift the safety collar on the tunnel cleanout lever and pull the lever down.

Once closed, release the lever and ensure that it returns to the neutral position and that the lock collar re-engages at the neutral position.

See Figure 61.

The tunnel cleanout is visible from the operator station. Visually check to ensure the stripper plate is against the frame and near the rotor.

See Figure 62.

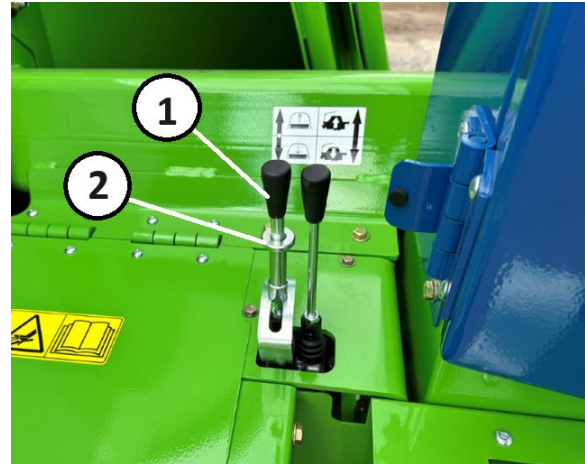

Figure 61. Tunnel Cleanout Lever
Key 1 – Lever Key 2 – Safety Collar



Figure 62. Stripper Plate Visual Check
Key 1 – Visual Check

Ag-Bagging Operation



DANGER:
To avoid serious injury, **DO NOT** climb on, around or in Ag-Bagger or conveyor while in operation. Falling into machine will result in serious injury or death.

IMPORTANT:

Instruct all unloading personnel how to communicate with the Ag-Bagger operator.

Safely engage the tractor PTO at and start the Ag-Bagger. Place the tractor in neutral, release the tractor brakes, and have the wheels directed straight ahead.

Note: The wheel brakes of the bagger should be already set and will hold the machine in place on a flat surface. If the machine moves in neutral, take corrective action to prevent movement before using the machine.

IMPORTANT:

Only operate the PTO at rated speed. Do not overspeed.

Start the conveyor. Pull the conveyor motor lever at the operator station. See Figure 63.

Begin unloading product onto the conveyor. The operator of the unloading equipment should monitor the conveyor or hopper such that it is unloading in the center of the hopper and not overloading the machine. Unloading equipment should be run accordingly.

Note: It may be beneficial at the start of the bag to have an operator in the

tractor seat and maintain brake pressure until the starting end of the bag is full.

NOTE:

Remember to keep the conveyor positioned such that the crop discharges to the center of the rotor for best performance. Note the conveyor position on the ruler decal. See Figure 64.

IMPORTANT:

The Ag-Bagger must be greased and lubricated during the Ag-Bagging operation. See the *Lubrication and Maintenance* section of this manual.



Figure 63. Conveyor Control Lever
Key 1 – Conveyor Motor On/Off (Pull)



Figure 64. Conveyor Position
Key 1 – Ruler Decal Key 2 – Marker

Start the inoculant applicator, if so equipped once product is being unloaded onto the conveyor. Turn inoculant applicator off just before load is empty.

IMPORTANT:

Be sure to turn off the inoculant applicator each time the conveyor is stopped.

Keep the anchors at the home position until the back of the bag has crop pushing it rearward and is completely in contact with the ground. This will likely be after approximately half of a load has been through the machine.

The anchors of the machine can be let out further during operation, but the conveyor may slow. The operator can also wait until after the first load is in the bag if desired.

Once the bag is started in this manner, set the anchor position control out for the anchors as follows:

- Alfalfa and Grasses: Position 4 to 6
- Corn silage: Position 6
- High Moisture Corn: Position 4

Typically, the further out the anchors are set, the higher the load. The control will allow the anchors to move further back, but they may not physically move until the machine begins to advance.

If on a soft surface where wheel brakes are not as helpful, set the position to 6.

Note: The scale indicates approximately how many feet of cable are let out with the anchor at that position. See Figures 65 and 66.

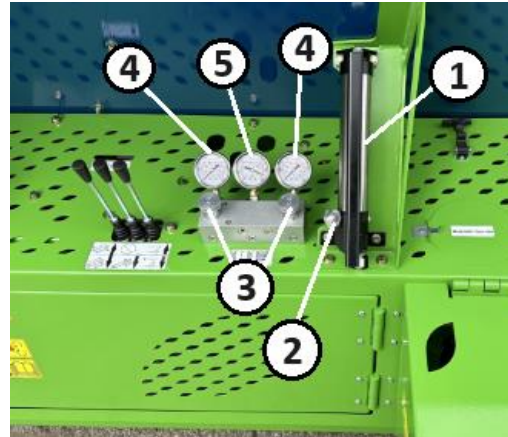

Figure 65. Brake System Control
 Key 1 – Hand Pump
 Key 2 – Pump Release
 Key 3 – Needle Valves and Lock Rings
 Key 4 – Brake Pressure Gauges
 Key 5 – Anchor Cylinder Pressure

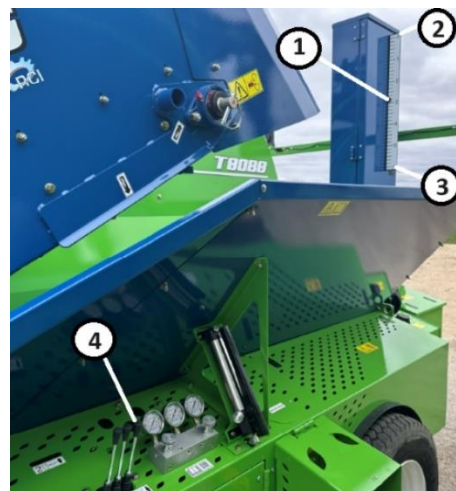

Figure 66. Anchor Position Control
 Key 1 – Indicator
 Key 2 – Home
 Key 3 – Anchor Out
 Key 4 – Control

As the bag fills, monitor the Stretch Bars of the Bag and the Ground-to-Ground Measurement. Do not exceed the bag manufacturer's recommendations.

If stretch marks are greater than recommended, reduce wheel brake pressure incrementally.

If operating on a wet or slippery surface, adjust the brake pressure to maximize the braking effort and adjust the anchor position out to increase the resistance.

The further out the anchors are placed, typically results in higher resistance for bagging.

To move anchors in, stop the conveyor to allow the hydraulic system to build pressure when actuating the anchor position control.

The pressure gauge for the anchors, at the middle of the gauges at the operator controls, will indicate how much work is being done by the anchor system.

When anchors are moved, it will take approximately 30 seconds to a minute for the system to stabilize to give an accurate reading, due to the check valves on the anchor cylinder.

In alfalfa and grasses, the anchors should typically see 1000 to 1300 psi.

In corn silage, the anchors should typically see 800 to 1000 psi.

However, conditions can play a factor in how much work the anchors will do

See Figures 67 through 69.



Figure 67. Ag-Bag Side
Key 1 – Stretch Bars

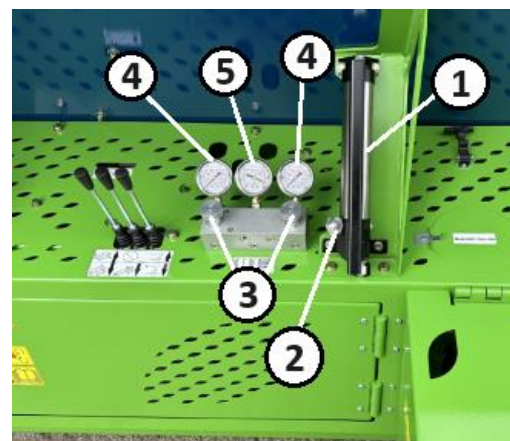
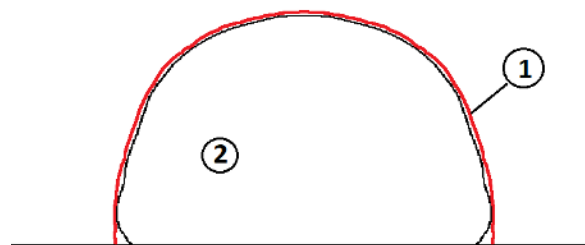

Figure 68. Brake System Control
Key 1 – Hand Pump
Key 2 – Pump Release
Key 3 – Needle Valves and Lock Rings
Key 4 – Brake Pressure Gauges
Key 5 – Anchor Cylinder Pressure



Key 69. Ground-to-Ground Measurement
Key 1 – Measurement Location
Key 2 – Ag-Bag

Sweeping Tunnel Cleanout Operation

To operate the Sweeping Tunnel Cleanout, it is important to remember to prepare for operation during the last load in the bag.

1. Half-way through the last load, stop the bagging process and conveyor and pull the anchors to the home position. See Figure 70.
2. Resume bagging and finish the bag.
3. At the very end of the load, safely and slowly release the wheel brakes. See Figure 71.
4. Once the load is complete, empty the conveyor, turn off the conveyor and raise the conveyor to the storage position.
5. Release the anchor position control to at least 4 on the scale. This limits the resistance on the cleanout.
6. Lower the engine speed to low idle. Turn off the PTO.
7. With the PTO off, lift the safety collar and push the lever to the tunnel cleanout open position and lock it into position. See Figure 72.
8. Return to the tractor. With the tractor in neutral, safely start the PTO and allow the tractor to move forward slowly. If it does not advance slowly with the opening of the tunnel cleanout, move the Ag-Bagger forward slowly about 5 feet (1.5 m).
9. Put the tractor in park and keep at low idle.

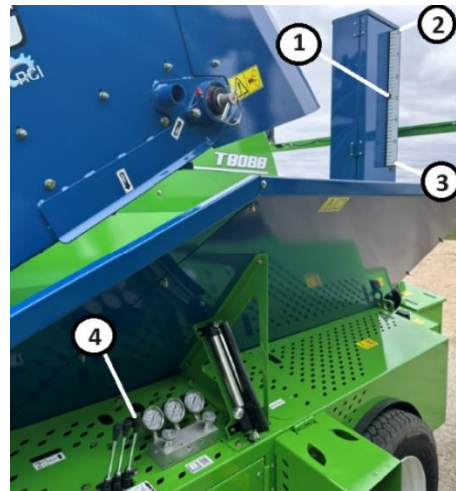

Figure 70. Anchor Position Control
Key 1 – Indicator Key 2 – Home
Key 3 – Anchor Out Key 4 – Control

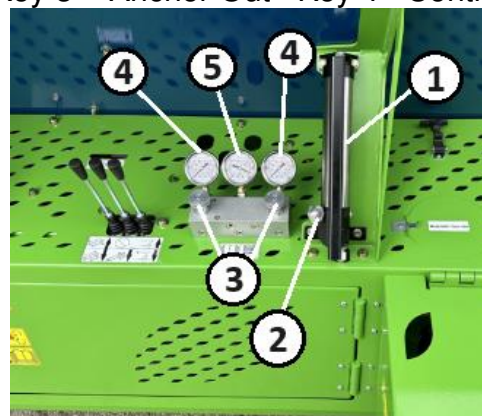

Figure 71. Brake System Control
Key 1 – Hand Pump
Key 2 – Pump Release
Key 3 – Needle Valves and Lock Rings
Key 4 – Brake Pressure Gauges
Key 5 – Anchor Cylinder Pressure

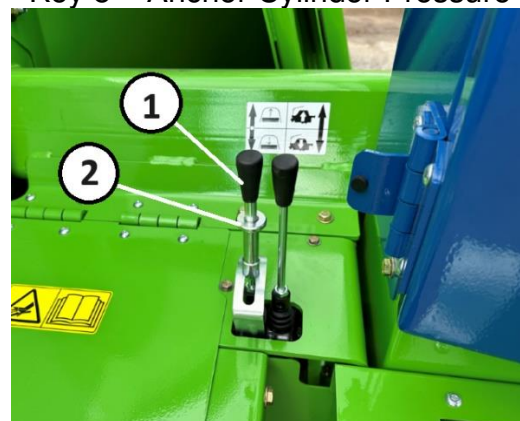

Figure 72. Tunnel Cleanout Lever
Key 1 – Lever Key 2 – Safety Collar

10. Lift the safety collar at the lever and pull the lever back to the neutral position. See Figure 75.
11. Activate the anchor position control to pull the anchors to the home position on the indicator. This is done with the cleanout in the open position such that all forage will press over and around the anchors and fall into the bag. See Figure 73.
12. Once the anchors are at the home position, return to the tractor and carefully pull the machine ahead approximately 3 feet (1 m). Place the tractor in Park. It is recommended to maintain an operator in the tractor seat at this stage to run the brakes if on a slope.
13. Return to the cleanout controls and run the cleanout fully in and out at least 3 times. On the final operation, move it fully to the closed position to prepare for the next bag. This helps to release any stuck material between the anchors and the tunnel into the bag.
14. Keep the anchors in the Home position if starting another bag. If the unit will be changed for transport, let the anchors out to Position 4 so the anchors can be pulled out for transport.
15. Return to the tractor and turn off the PTO. Carefully and slowly drive the tractor forward until the bag pulls off the tunnel or enough plastic is exposed to be able to seal the bag, and then cut the plastic as needed.
16. Turn off the tractor PTO, put the tractor into park and remove the key.

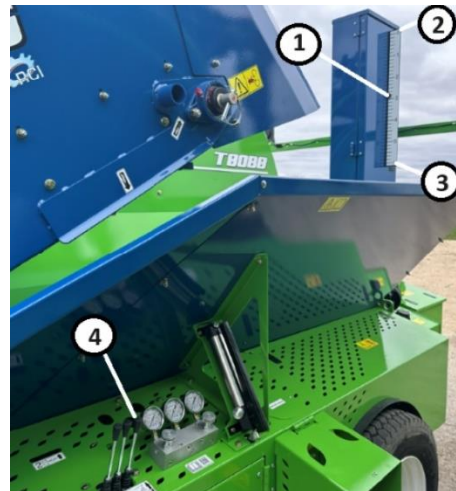

Figure 73. Anchor Position Control
Key 1 – Indicator Key 2 – Home
Key 3 – Anchor Out Key 4 –Control

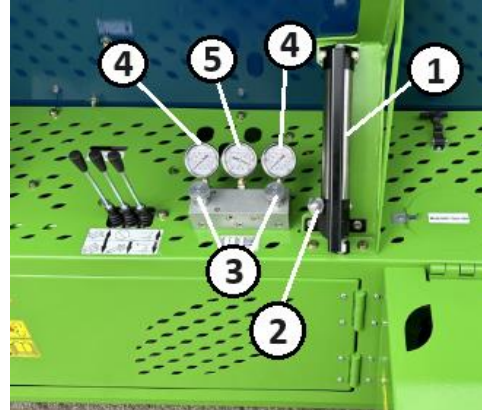

Figure 74. Brake System Control
Key 1 – Hand Pump
Key 2 – Pump Release
Key 3 – Needle Valves and Lock Rings
Key 4 – Brake Pressure Gauges
Key 5 – Anchor Cylinder Pressure

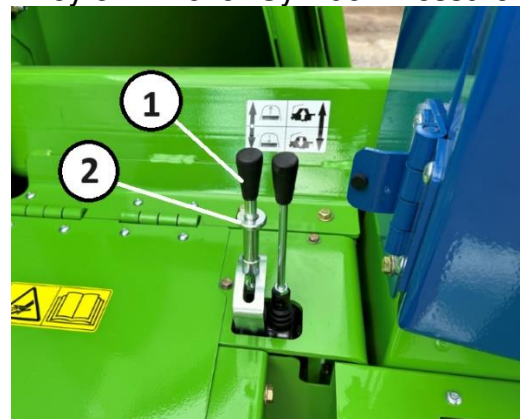

Figure 75. Tunnel Cleanout Lever
Key 1 – Lever Key 2 – Safety Collar

Removing the Ag-Bag from the Ag-Bagger

Once the bag is off the tunnel, stop the tractor, put in park, shut off engine and remove key.

If there is any material remaining in the tunnel, clean it out into the Ag-Bag or dispose of by other means.

Grab each side of the bag on the end.

Walk the bag over itself pulling the product together.

Bring the Ag-Bag end forward.

Seal the end of the Ag-Bag in the same manner as the beginning end of the Ag-Bag.

See *Seal the Beginning End of the Ag-Bag* section in this manual.

NOTE:

With any method used to seal the end of the Ag-Bag, loose plastic must be weighted down to prevent damage. When doing so, DO NOT use material that will be abrasive or sharp against the Ag-Bag material.

See Figures 76 through 79.



Figure 76. End of Ag-Bagging

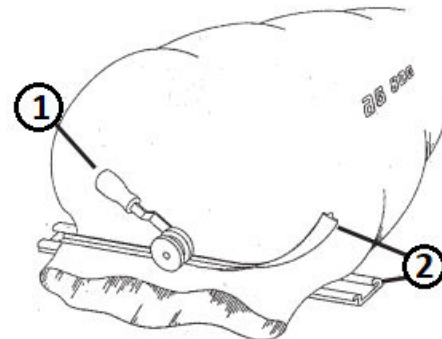

Figure 77. Master Seal Concept
Key 1 – Master Seal Tool
Key 2 – Master Seal

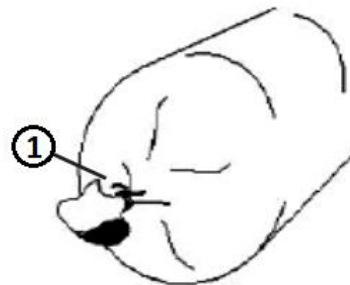

Figure 78. Start of Double-Knot Tie
Key 1 – First Tie

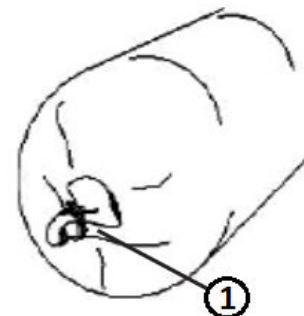

Figure 79. End of Double-Knot Tie
Key 1 – Fold Over and Second Tie

Venting the Ag-Bag

Immediately after the Ag-Bag is sealed, a vent must be installed to remove the gases produced by the product.

A reusable vent valve and vent tool are available from your Ag-Bag dealer. See Figure 80.

To install the vent valve, remove the cover from the vent cutter tool.

Turn the cutting portion of the tool such that the cutter is away from the cover, line up the notches and insert the cutter into the cover.

Take the threaded side of the valve, align the notches and slide it over the cutter end of the tool.

Slide the threaded portion completely onto the cutter. See Figure 81.

Once the desired valve location is determined, press the cutter portion of the tool into the plastic to create a hole.

Push the tool with the threaded portion of the vent through the hole and pull the cutting tool out, leaving the threaded end of the vent protruding through the Ag-Bag. See Figure 82.

Assemble the valve lid onto the threaded portion.

Turn the lid counterclockwise and tighten securely. See Figure 83.

Slide the lid of the vent open such that gases can escape. Within 1 to 2 days, close the lid and leave the vent in the Ag-Bag until that end of the Ag-Bag is consumed.

Part Number	Description
AA1500893	Reusable Vent Valve
AA1500568	Vent Installation Tool

Figure 80. Vent Valve Components

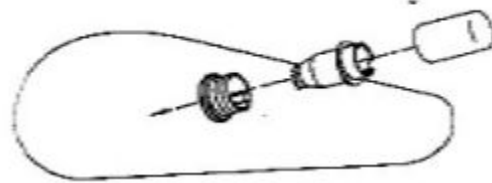

Figure 81. Valve Preparation

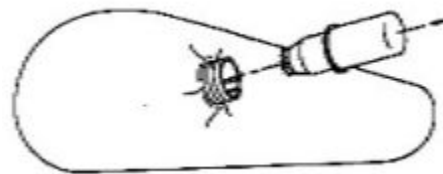

Figure 82. Hole Cutting

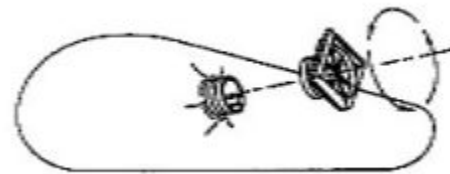

Figure 83. Lid Installation

NOTE:

If excessive gassing occurs, leave the vent open an additional day. If the Ag-Bag expands again with gases after closing the valve, open the valve again until the gases recede, then close the valve.

Moving Wheels to Transport Position

IMPORTANT:

Site for moving wheels must be level to prevent Ag-Bagger from rolling when unhitched from the towing vehicle. Ground conditions must be firm to prevent lift jacks from settling during wheel removal.

IMPORTANT:

Keep service door closed whenever the tractor is running to shield moving components around the hydraulic pump drive. Failure to do so may result in serious injury.

IMPORTANT:

Before moving wheels to transport position, make sure the conveyor is raised fully and the transport lock engaged. See Figure 84.

IMPORTANT:

Before moving wheels to transport position, make sure the anchors are moved to the transport hooks on the cleanout. The anchor position control must be set to 4 or greater to do this.

IMPORTANT:

The wheel brake pressure must be fully released prior to disconnecting the brake calipers. Breathers must be installed at the wheel brake couplers for transport to prevent machine damage.



DANGER:

Never work under the machine when in a raised condition. If service work is needed, use proper blocks and technique to secure the machine in a raised condition before performing any work. Failure to do so may result in serious injury or death.



Figure 84. Conveyor Lift Lock
Key 1 – Lock Lever Key 2 – Marker



Figure 85. Lift Jack Storage
Key 1 – Lift Jack
Key 2 – Storage Compartment (ref)

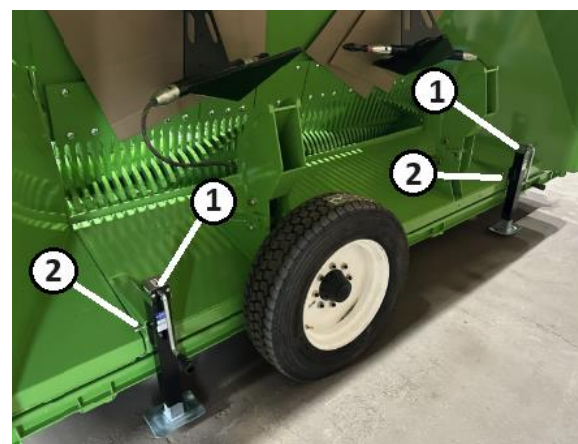

Figure 86. Lift Jack Usage
Key 1 – Lift Jack Key 2 – Cross Pin

Clear the area of bystanders and safely start the tractor and start the PTO at low idle.

Keeping the tractor in park and at low idle, go to the operator station at the Ag-Bagger and push the lever for machine lift. See Figure 87.

As the lever is pushed to raise the machine, the lift pads will lower to the ground and then raise the machine.

Raise the machine enough to have clearance to install the front tire (near the gearbox).

Return the lever to the neutral position and return to the tractor. Turn off the PTO, shut off the engine, keep the tractor in park and remove the key.

With the brake pressure removed, disconnect the brake lines and install the cap on the line. Install the breather from the storage compartment at each wheel.

Move the wheel and spindle assemblies from the Ag-Bagging position to the transport position.

Each wheel is held in position with a cross pin with a lynch pin in the end as a retainer. Remove the lynch pin and cross pin.

Move the wheel and spindle assemblies to the transport position at the sides of the machine. Install the spindle into the tube cross hole and align the hole. Install the cross pin and the lynch pin for a retainer.

Repeat at each end of the machine. See Figures 87 through 90.



Figure 87. Operator Controls
Key 1 – Machine Lift / Lower Lever

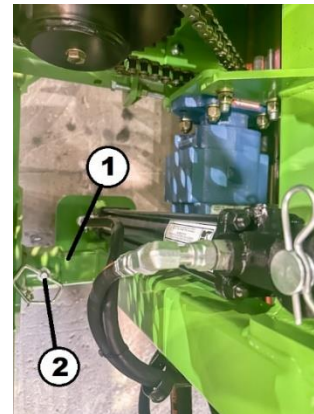

Figure 88. Left Side Spindle Removal
Key 1 – Spindle Assembly Key 2 – Pin

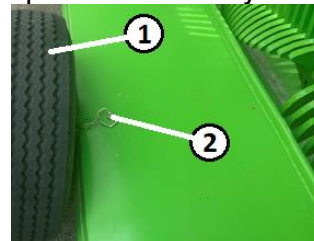

Figure 89. Right Side Spindle Removal
Key 1 – Spindle and Tire Assembly
Key 2 – Pin

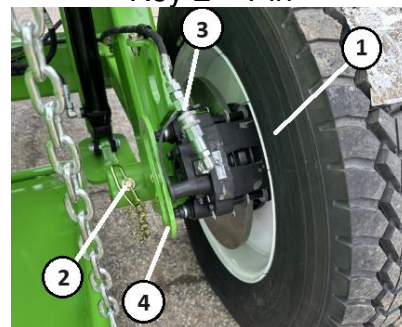

Figure 90. Spindle Install for Ag-Bagging
Key 1 – Tire Key 2 – Cross Pin
Key 3 – Breather + Line Key 4 – Handle

lower the jack stand at the towing hitch end of the machine while the machine is in a raised position. Secure the jack stand in the lowered position with the cross pin and lynch pin.

See Figure 91.

Ensure that all shields are closed on the machine. Clear the area of bystanders. Return to the tractor. Safely start the tractor and start the PTO at low idle while keeping the tractor in park.

Return to the operator controls of the Ag-Bagger.

Activate the lever for machine lowering. The lift jacks will raise, and the machine will lower to the ground. Continue raising the lift arms for approximately 10 seconds to ensure they are raised fully to the storage position. Return the lever to neutral. See Figure 94.

Return to the tractor. Turn off the PTO, shut off the engine, keep the tractor in park and remove the key.

Before removing the tractor from the machine, ensure that the anchors are on the storage hooks on the cleanout door. To do this, the cleanout door must first be closed. Then the anchor position control must be at Position 4 or higher to allow the operator to pull the anchors out by hand enough to have enough slack to reach the hooks.

Fold up the anchor supports. Return to page 22 for more information if needed.

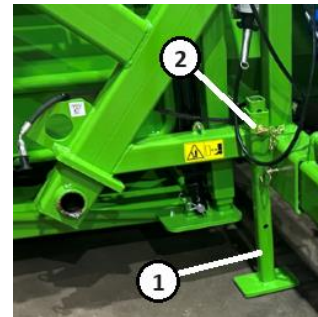

Figure 91. Jack Stand Raising
Key 1 – Jack Stand
Key 2 – Cross Pin

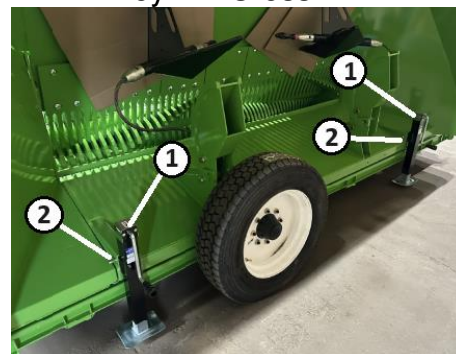

Fig. 92. Lift Jack Usage and Jacks
Key 1 – Lift Jack Key 2 – Cross Pin



Figure 93. Lift Jack Storage (T7170)
Key 1 – Lift Jack Key 2 – Storage (ref)



Figure 94. Operator Controls
Key 1 – Machine Lift / Lower Lever

Remove the PTO shaft from the tractor.

Remove the retaining chain from both ends of the PTO shaft shield. Raise the PTO shaft guard up and secure it with the rubber latch at the top center.

Move the PTO shaft to the storage location. Alternatively, the PTO shaft can remain connected to the gearbox and the other end swung to the conveyor and retained with the support chain (if transport width restrictions allow for wide transport width). See Figures 95 and 96.

Remove the pin and rotate the lift jack on the tow hitch to the down position. Fasten the lift jack to the hitch in the down position for lifting.

Remove the hitch pin and then the lift jack from the hitch. Remove the cross pin on the hitch and remove the hitch from the machine.

Relocate the hitch to the transport side of the machine and reinstall with cross pin. Handles are provided for ease of moving the hitch.

Install lift jack on hitch and raise to appropriate height for the towing vehicle.

Raise the jack stand at main frame to the highest position and reinstall the cross pin and lynch pin. See Figure 97.

NOTE:

A safety chain and wire harness are provided for connection to the towing vehicle. Always use these components, verify their functionality before use, and verify that the Ag-Bagger is prepared properly for local DOT regulations.

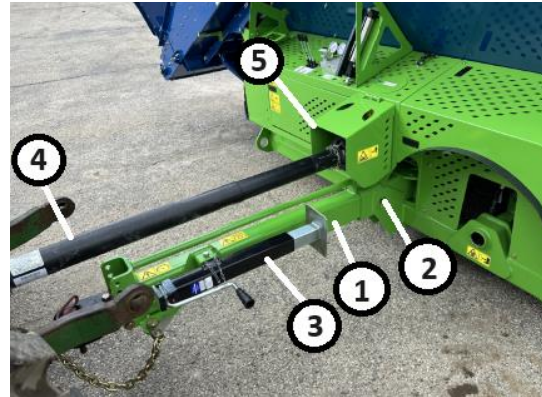

Figure 95. Hitch in Ag-Bagging Position
Key 1 – Hitch Key 2 – Hitch Cross Pin
Key 3 – Lift Jack
Key 4 – PTO Tractor End
Key 5 – PTO Shield

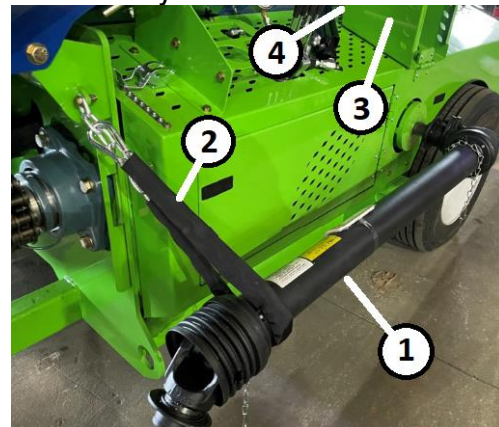

Figure 96. Alternate PTO Storage
Key 1 – PTO Shaft Key 2 – Chain
Key 3 – PTO Cover Key 4 - Latch

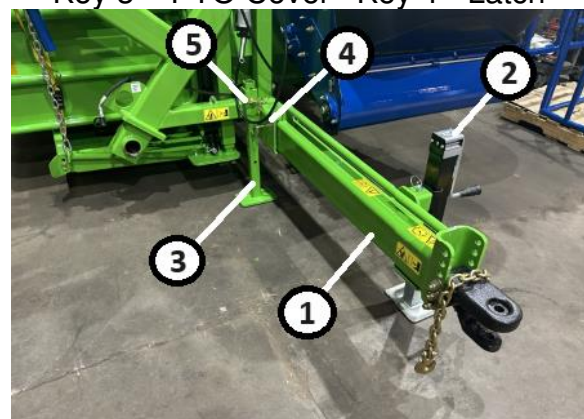

Figure 97. Hitch in Transport Position
Key 1 – Hitch Key 2 – Lift Jack
Key 3 – Jack Stand
Key 4 – Hitch Cross Pin
Key 5 – Jack Stand Cross Pin

Tunnel Storage

The tunnel extension is stored above the main tunnel for transport. It is recommended to use the help of an assistant for this operation.

The bag cradle is used in a raised position to lift the extensions from the installed position to the storage position.

With the cradle resting on the extension in the installed position, flip the angles at the bottom over center and under the hook points on the tunnel extension. See Figures 98 and 99.

Once flipped, crank the bag boom cable winch to take the weight of the extension. Remove the pins at the storage location.

Raise the tunnel extension approximately 3" (75 mm). Swing the bag boom and tunnel around until the tunnel is in the storage location. See Figure 100.

NOTE:

Push the extension into storage position and install the previously removed pins at the base tunnel where the extension is stored. The hitch pin clips are retained at the storage mounts. See Figure 100.

Secure the bungee cord to the hooks at the corner of the bag pan for transport.

The bag boom should be adjusted down over the top of the bag cradle for transport as needed. An alternative is to use ratchet straps to secure the cradle to the machine to prevent it from moving during transport.

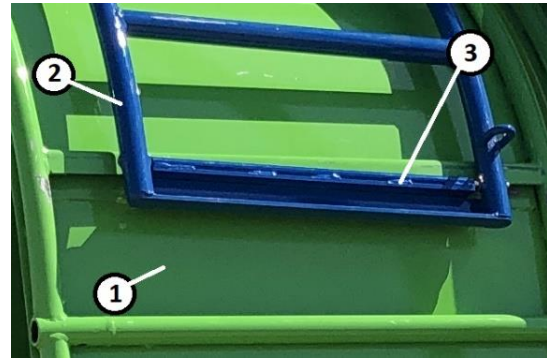

Figure 98. Cradle Hook
Key 1 – Extension Key 2 – Bag Cradle
Key 3 – Cradle Hook

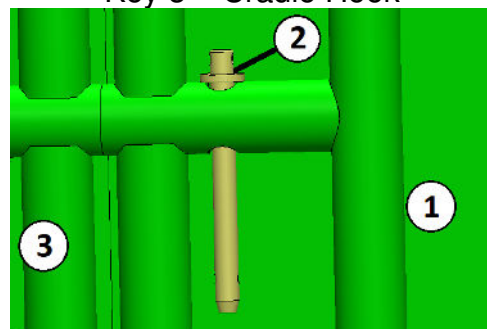

Figure 99. Pin Installation
Key 1–Tunnel Key 2–Pin Key 3–Ext.

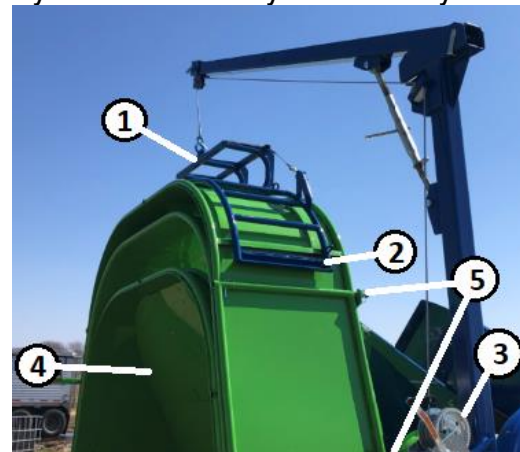

Figure 100. Tunnel Extension Lift
Key 1–Bag Cradle Key 2–Cradle Hook
Key 3 – Winch Key 4 – Base Tunnel
Key 5 – Storage Pin Locations

Transporting the Ag-Bagger

Before transporting the Ag-Bagger, perform an inspection of the unit to ensure it is safe for transport.

A safety chain is provided for the hitch to the towing vehicle. Always use the safety chain when transporting the Ag-Bagger on public highways.

Check the tire air pressure and wheel lug nut torque. Refer to the *Lubrication and Maintenance* section of this manual.

Verify that all components are secured properly, including the bag cradle, bag pan and bungee cord.

Verify the conveyor is in the raised position and the transport lock pin is fully engaged. See Figure 102.

Verify the electrical connector is connected properly. The connector stores in a holder on the frame and the excess cord can be wound around the hitch or the frame. See Figure 103.

Verify all lighting and marking is in place and operational, including the SMV sign at the rear.

Always use a hitch pin with a retainer device to prevent inadvertent removal.

Lower the bag boom to the bag cradle to reduce the height of the machine if needed or when transporting the machine long distances. See *Bag Boom Adjustment* section in this manual.



WARNING:
DO NOT TOW THIS IMPLEMENT OVER 25 mph (40 kph). Failure to abide may result in serious injury and / or machine damage.



Figure 101. Ag-Bagger Transport



Figure 102. Conveyor Lift Lock
Key 1 – Lock Lever

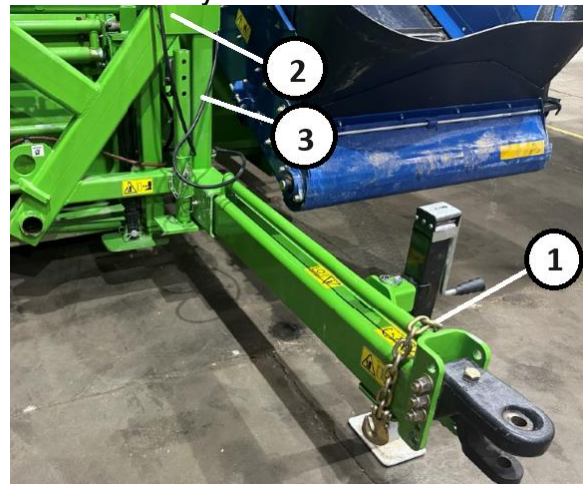

Figure 103. Transport Hitch Position
Key 1 – Safety Chain
Key 2–Harness Holder Key 3–Harness

To narrow the transport width of the Ag-Bagger to 102 inches wide (2.6 m), fold in the conveyor extension, place the PTO in the rear storage position, and move the conveyor motor to the top support bracket for storage.

For narrow transport, the tunnel extension must all be installed on top of the tunnel in storage. See Figure 104.

To fold the conveyor extension in for transport, remove the two lynch pins at the hinge joint in the extension.

Move the extension to the inner position and reinstall the pins.

See Figure 105.

To move the conveyor motor to the storage position, first remove the cover from the assembly and remove the lynch pin from the coupler. Move the motor to the support bracket on top. Reinstall the lynch pin on the coupler. The hose bushing on the motor mount will help retain the motor in position.

See Figure 106.



Figure 104. Narrow Transport
Key 1 – PTO Rear Storage



Figure 105. Conveyor Extension
Key 1 – Lynch Pins Key 2 – Extension

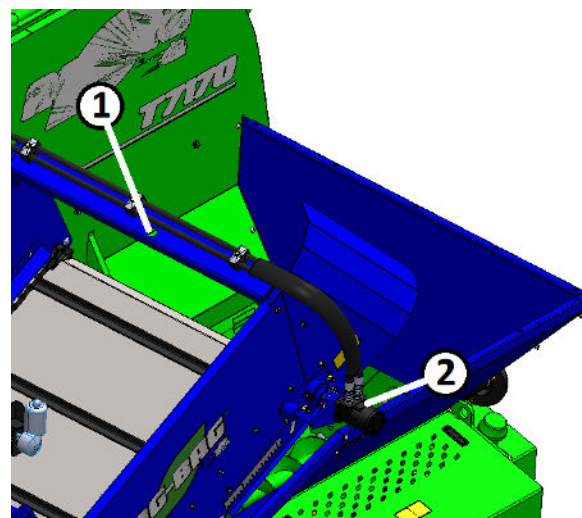

Figure 106. Conveyor Motor Storage
Key 1 – Storage Location
Key 2 – Motor Assembly

9 PERFORMANCE OPTIMIZATION

There are many factors that impact the performance of the Ag-Bagger as well as the quality of the silages produced.

Use the following information to ensure that the system produces the highest quality of silage an Ag-Bag can offer.

Conveyor Position

With the T8088, the Revolutionary Rotor allows for more throughput and higher bag density than previous models of Ag-Baggers.

The single greatest adjustment that can be made to impact the performance of the T8088 Ag-Bagger is the conveyor position.

To maximize throughput and bag density, the product must be delivered to the rotor and forage distributor at the very center of the machine.

This allows the rotor and forage distributor to properly distribute and pack the product into the Ag-Bag in the most efficient manner possible.

A ruler decal is provided on the machine for the operator to mark a common location using a marker, for ease of repeatability.

Different positions may be used in different crops.

By marking the position on the ruler, the operator can easily return the conveyor to the known optimum location.

A decal is provided above the rotor as a reminder of ideal crop flow location.

See Figures 107 through 109.

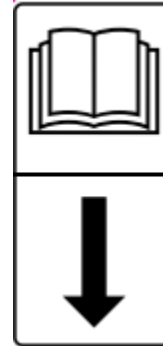

Figure 107. Optimum Crop Flow Reminder



Figure 108. Optimum Crop Flow at Center
Key 1 – Decal Location
Arrow – Optimum Crop Flow Location



Figure 109. Conveyor Position
Key 1 – Ruler Decal Key 2 – Marker

Tractor Setup

The proper tractor size and configuration is essential to performance. Select the proper based on the machine specifications in this manual.



WARNING:
NEVER use a PTO Spline Adapter. Failure to follow this precaution may result in machine damage, severe injury, or death.

Use of an adapter will void warranty for the Ag-Bagger due to high potential for damage to the tractor PTO, PTO driveshaft or other Ag-Bagger components.

Always maintain the proper PTO rpm for the machine. Do not over-speed the Ag-Bagger. Changes in speed will impact the delivery point of the conveyor as well as the performance of the rotor.

Over-speeding the driveline not only reduces reliability and voids warranty, but it decreases throughput and can cause crop over-processing due to the Revolutionary Rotor design. The rotor is designed to run at a very specific rpm to maximize throughput and bag density.

Always follow the Power Shut Down Procedure outlined at the beginning of this manual in the *Safe Operation of Machine* section.

Crop Conditions

Maturity

Ideal maturity for grasses and alfalfa is pre-bloom. Ideal maturity for corn silage is around 50% milk line in the kernel, or about 42 to 47 days after silking. It is more important to maintain the proper moisture for the crop in the Ag-Bag.

Product Moisture

The desired moisture level for proper ensiling in an Ag-Bag is typically 60 to 65 percent.

At too high of moisture, fermentation can be negatively impacted, in addition to lost nutrients in “juicing” of the product during the Ag-Bagging process.

At too low of moisture, too much oxygen may be trapped in the product, negatively impacting fermentation.

Refer to the different materials available at www.ag-bag.com or from your local Ag-Bag dealer for more detailed information on product moisture levels.

Moisture levels play an important part of product quality.

Dry product makes for a lumpy Ag-Bag. Long dry chop is hard on any Ag-Bagger. It is important to remember when trying to make quality haylage, dry forages have more resistance. They will pack higher in the Ag-Bag and lower cable drum brake pressure is required.

Wet product typically refers to product with moisture levels above 70%. Wet product may create excessive liquid in the hopper. This excessive liquid is acceptable unless the Ag-Bag is outside the recommended shape.

Slowly release the cable drum brake pressure until the Ag-Bag is within the recommended shape.

Allow the product to wilt longer in the field if liquid does not dissipate. Wet product does not rise very high in the Ag-Bag. The result will be a wide Ag-Bag.

NOTE:

The possibility of Ag-Bag damage will result from cables contacting a wider-shaped Ag-Bag. Place cardboard between the Ag-Bag and cables if contact will or has occurred.

Crop Management

Crop management in this case refers to length of cut and processing of the product.

Varying length of cut with moisture has benefits for better packing in an Ag-Bag.

With dryer materials, a shorter length of cut will help ensure ensiling in an Ag-Bag will help to reduce the oxygen in the product.

With wetter materials, a longer length of cut will reduce the excess moisture and help to pack a tighter Ag-Bag.

Ag-Bag Site

Select an Ag-Bag site that has a flat, firm surface and room for operating equipment both during the Ag-Bagging and unloaded operations.

The surface used for Ag-Bagging is as important as the setup of the machine used in terms of product quality.

When placing Ag-Bags next to one another, leave approximately 3 feet (1 m) of distance between Ag-Bags for

maintenance, inspection, and to allow access for unloading without damage to nearby Ag-Bags.

Remove any rocks, sticks and foreign material from the site. Proper drainage of the site is important as well. Concrete, asphalt, gravel, or packed limestone works well under Ag-Bags.

Pick a site away from rodent infestations or habitat or create a border zone around the Ag-Bag site to deter rodents from invading the site.

Protect the site from livestock with fencing if needed. Cattle are drawn to the wholesome deliciousness found in an Ag-Bag. If the job is done right, cattle will need to be restrained.

Ag-Bagging Surface



WARNING:

Do not Ag-Bag on a hillside. Tip-over or rollover of equipment or Ag-Bag may result.

Always Ag-Bag uphill rather than downhill. Adjust brake pressure as needed. The Ag-Bagger can drift, and the Ag-Bag may roll.

Site surface conditions may affect Ag-Bagging quality and ability.

Soft ground conditions will act as a brake and may cause the Ag-Bagger to sink.

A hard, clean surface is best to Ag-Bag on. By cleaning the area, rodent problems can be prevented.

Ag-Bag Installation

Enclosed in each box of Ag-Bags is an instruction sheet with pictures to help properly install the Ag-Bag on the Ag-Bagger.

Take time to understand the best method of Ag-Bag installation. The Ag-Bag should be placed on the machine with the Ag-Bag logo in an area between 1 and 3 o'clock when standing behind the bag and machine.

Ag-Bagging Pressure

When filling the Ag-Bag, the Ag-Bag should not be stretched more than 2 inches (5 cm) above the tunnel, nor should the Ag-Bag push against the cables.

Less brake pressure is required when:

- a. Ag-Bagging uphill
- b. Ag-Bagging with a large tractor due to weight and resistance to roll
- c. Ag-Bagging in muddy or soft, sandy soils due to drag
- d. Ag-Bagging extremely wet product, above 75% moisture
- e. Ag-Bagging dry grains, which make a flatter Ag-Bag. The product going into the Ag-Bag will not always reach to the top of the tunnel.
- f. Ag-Bagging oats and winter forages. These should only be packed to the top of the tunnel because of swelling during storage. It is recommended to keep stretch at a minimum due to the product swelling.

More brake pressure is required when:

- a. Ag-Bagging on hard surfaces such as concrete and asphalt as there is less drag for the equipment to roll forward
- b. Ag-Bagging downhill.

Correcting Ag-Bag Stretch

To measure ground to ground distance over the Ag-Bag, tie weights such as hex nuts of approximately ¼ pound (1/10 kg) to one end of a string and one weight of approximately half as much to the opposite end of the string. The distance between the nuts needs to be:

- 21 feet (6.4 m) for 10-foot Ag-Bags

Carefully straddle the string over the Ag-Bag approximately 15 feet away from the Ag-Bagger.

While Ag-Bagging, when the lighter side touches the ground, increase the anchor position out.

If the nut comes off the ground more than 3 inches (7.5 cm), reduce the anchor position in.

NOTE:

Use this procedure only as a visual aid. Measuring the stretch bars on the Ag-Bag and maintaining appropriate stretch dimensions is more important. Keep the Ag-Bag stretch indicators within the manufacturer's specifications.



Sealing and Venting

As soon as the Ag-Bag is filled, seal the finished end of the Ag-Bag as outlined in the Master Seal instructions.

The earlier that oxygen is sealed out, the earlier the fermentation process can begin. It is very important to vent the Ag-Bag after sealing. See *Venting and Sealing* section of this manual.

Order Master Seal and reusable vents from an Ag-Bag dealer. Refer to the following for specific part numbers.

<u>Part Number</u>	<u>Description</u>
AA1500893	Reusable Vent Valve
AA1500568	Vent Installation Tool
AA1500272	250 ft. Roll
AA1500270	9.5 ft. Long, 4/Box
AA1500267	14.5 ft. Long, 4/box*
AA1500268	17 ft. Long, 4/ Box**
AA1500269	20 ft. Long, 4/Box***
AA1500273	Zip Tool

* 9 ft. Ag-Bags ** 10 ft. Ag-Bags

*** 11 and 12 ft. Ag-Bags

Wind Damage

Wind damage can be caused by the wind whipping the loose end of the Ag-Bag.

To prevent damage, the loose Ag-Bag end needs to be secured with Master Seal and by placing tires or other soft material on the end of the Ag-Bag.

Wind damage can cause small cracks and eventually wear a hole that allows air to penetrate, causing feed damage.

A tightly secured Ag-Bag will add to the life of the Ag-Bag.

Bad Weather Ag-Bags

Ag-Bags should always be placed in a location that feed out can be achieved

when you need the feed, no matter the weather conditions.

Consider the surface conditions during the seasons when the product will be removed from the Ag-Bags.

If mud is expected at the time of feed out, consider another location on a harder surface.

Plan to have enough accessible Ag-Bags for the time of year needed, and to last until favorable weather conditions can be expected.

Remember, just because crops don't grow on the wet spot in the corner of the field by the farm, it does not mean that the crops should be stored there.

Ag-Bag Shape

Haylage and Corn Silage Ag-Bag Shape

Apply enough anchor position and wheel brake pressure to fill the Ag-Bag within 2 inches (5cm) from the top of the tunnel. Keep the Ag-Bag stretch indicators within the Ag-Bag manufacturer's specifications.

Grains

Grains tend to not fill the Ag-Bag to the top of the tunnel, regardless of cable pressure. Regulate cable pressure by measuring your stretch bars approximately 30 feet (9 m) back from the Ag-Bagger. Keep the stretch indicators within the Ag-Bag manufacturer's specifications.



Ag-Bag Management and Inspection

Periodic inspection of the Ag-Bag is essential to maintain the oxygen-free environment inside the Ag-Bag.

It is recommended that repairs be made with Ag-Bag mending tape as soon as damage is discovered.

Repair tape can be ordered from your Ag-Bag dealer using the following part numbers.

Part Number	Description
AA1500523	2"x36 yd. (5cm x 33m) roll
AA1500525	3"x36 yd. (8cm x 33m) roll
AA1501331	4"x36 yd.(10cm x 33m) roll

Suggested Feed Out Rates Per Day

Winter Rates (Oct. through April)

<u>Bag Size</u>	<u>Feet/Day</u>	<u>Tons/Day</u>
10 ft.	2 ft.	3
12 ft.	2 ft.	4

Summer Rates (May through Sept.)

<u>Bag Size</u>	<u>Feet/Day</u>	<u>Tons/Day</u>
10 ft.	2-1/2 ft.	4
12 ft.	3 ft.	6

Capacity of Tons per Running Foot of Ag-Bag

10 ft. Ag-Bag.....1-1/2 Tons (approx.)

12 ft. Ag-Bag.....2 Tons (approx.)



Genuine Ag-Bag Capacity Chart

Bag Size	Bags per Pallet	Range of Tons/Bag 65% M Alfalfa	Range of Tons/Bag 35% M Earlage	Range of Tons/Bag 28-30% M Shelled Corn	Approx. 56# Bushels per Bag
6x100'	24	52-60	48-52	50-55	-
6x150'	24	85-98	78-85	90-95	-
6x200'	24	117-135	108-117	115-125	-
8x100'	16	80-90	70-80	80-90	3000
8x150'	12	120-140	120-130	130-140	3825
8x200'	10	170-190	164-180	180-200	5294
9x135'	12	140-160	134-150	150	4411
9x150'	12	160-180	162	175	6125
9x200'	10	200-225	205	230	6765
10x150'	10	200-220	180	202	5940
10x200'	8	270-300	247	278	8175
10x250'	6	340-360	324	350	12250
10x300'	6	420-490	400	420	14320
12x250'	6	420-480	420-480	450	16071
12x300'	4	500-550	500-550	500	17238
12x500'	2	840-900	840-900	900	32000
14x300'	4	700-840	700-840	-	-
14x400'	2	950-1,140	950-1,140	-	-
14x500'	2	1,200-1,440	1,200-1,440	-	-

These numbers are estimated values only to provide a guide on total capacity. Exact tons or bushels are based on length of cut, moisture, variety, and pack density.

The best way to measure total capacity is weighing each load before storing forage or grain.

10 ADJUSTMENTS

Conveyor Position

The single greatest adjustment that can be made to impact the performance of the T8088 Ag-Bagger is the conveyor position.

To maximize throughput and bag density, the product must be delivered to the rotor and forage distributor at the very center of the machine.

This allows the rotor and forage distributor to properly distribute and pack the product into the Ag-Bag in the most efficient manner possible.

A ruler decal is provided on the machine for the operator to mark a common location using a marker, for ease of repeatability. See Figure 110.

Different positions may be used in different crops. By marking the position on the ruler, the operator can easily return the conveyor to the known optimum location.

A decal is provided above the rotor as a reminder of ideal crop flow location. See Figures 111 and 112.

The tractor PTO must be safely engaged before operating the hydraulic conveyor raise and lower control.

Before lowering the conveyor, release the conveyor lift lock at the upper end of the slide rail. Pull the lock down and rotate to retain the pin in a disengaged condition to release the conveyor lift lock. See Figure 113.

Lower the conveyor down to the operating position by pushing the hydraulic conveyor lift control lever in.



Figure 110. Conveyor Position
Key 1 – Ruler Decal Key 2 – Marker

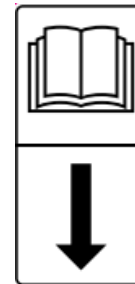

Figure 111. Optimum Crop Flow Reminder



Figure 112. Optimum Crop Flow at Center
Key 1 – Decal Location
Arrow – Optimum Crop Flow Location



Figure 113. Conveyor Lift Lock
Key 1 – Lock Lever

The control lever will return to the centered (neutral) position when released. Pulling the control lever will raise the conveyor.

See Figure 114.

The conveyor must not rest on the ground when Ag-Bagging.

Keep the conveyor approximately six inches off the ground.

The conveyor position must be adjusted such that the discharge material of the conveyor lands directly in the center of the rotor at normal operating speed.

This position can be marked and monitored using the ruler decal at the side of the conveyor.

See Figure 115.

Conveyor Angle

The conveyor angle is adjustable for rare occasions where the hopper angle must be adjusted to accommodate a special unloading device.

The standard position is in the center hole.

To change, using a jack to safely lift the bottom of the conveyor. Move remove the bottom bolt at the main frame. Move the conveyor and A-arm to the desired position and reinstall the bolt. Tighten hardware properly.

Always reset the conveyor position after changing the conveyor angle as the discharge point of the crop flow will be different.

See Figure 116.

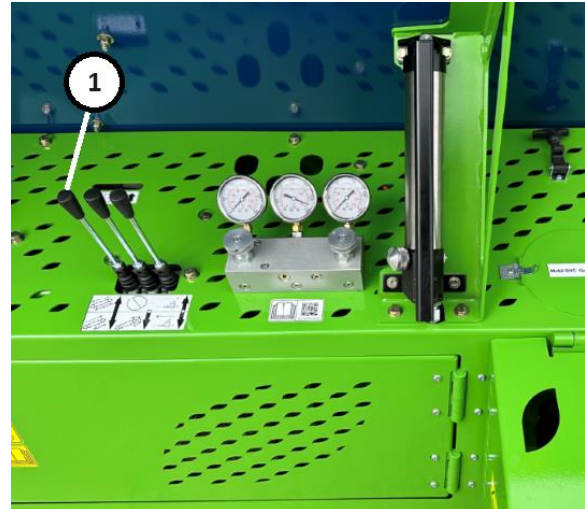

Figure 114. Conveyor Raise and Lower
Key 1 – Control Lever



Figure 115. Conveyor Position
Key 1 – Ruler Decal Key 2 – Marker

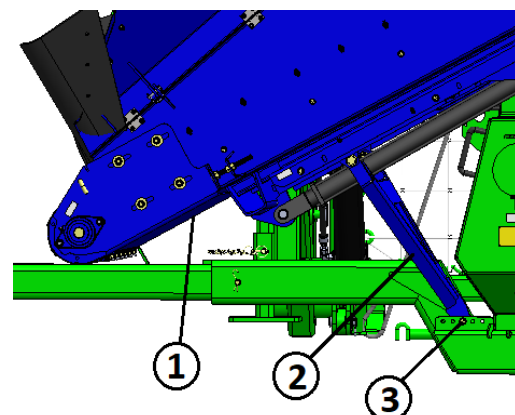

Figure 116. Conveyor Angle
Key 1 – Conveyor Key 2 – A-Arm
Key 3 – Bolt at Main Frame

Conveyor Chain



WARNING:
DO NOT lubricate, adjust and/or service this Ag-Bagger unless the *Power Shut Down Procedure* in the *Safe Operation of Machine* section of this manual has been exercised.

The shingles over the chains at the sides of the conveyor need to be removed for cleaning and for evaluation of the chain tension. Therefore, it is best to perform this work prior to storage at the end of the season, so the unit can be cleaned thoroughly.

A simple check for tension when in use is if the lower shaft is rotating when in use. If it is not rotating, it indicates the chain is rolling around the cast pulleys on the bottom shaft instead of having the roller rotate with the shaft on the bearings at the side. This condition can cause accelerated wear of the cast pulleys. Tension should be increased so the lower idler shaft and bearings turns with the chain.

SPECIFICATION:

Conveyor Chain Tension

At the middle of the conveyor, lift the chain 1.5 to 2 inches (4 to 5 cm) with approximately 75 lbs. (34 kg) of force.

At the lower end of the conveyor, loosen the four retainer nuts on the carriage bolts on each side of the conveyor. Loosen the jam nut on the adjusting bolt on each side of the conveyor.

Turn the adjusting nuts so the adjusting bolts measure the same distance on both sides until the chain reaches proper tension. Once the specification is

achieved, tighten the jam nuts on each adjusting bolts. Tighten the four retainer nuts on the carriage bolts on each side of the conveyor.

Set the shingle and lower guide clearance to 3/16" of clearance to the chain when all components are clean. See Figures 117 through 119.

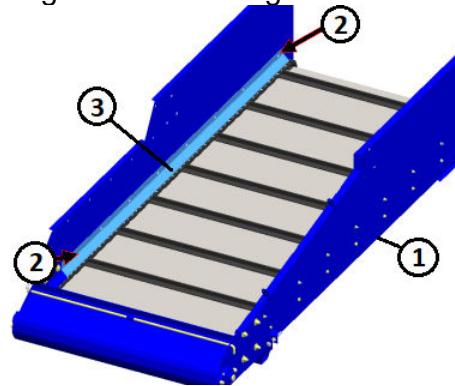

Figure 117. Conveyor Adjustments
 Key 1 – Conveyor Key 2 – Shingle
 Key 3 – Gap Measurement Location

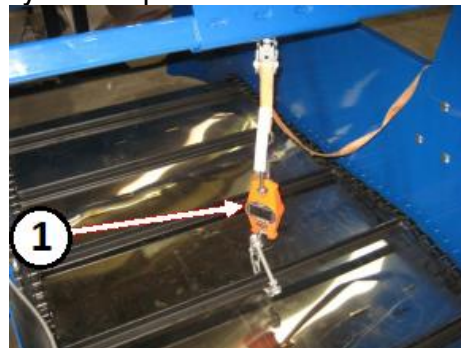

Figure 118. Conveyor Chain Tension
 Key 1 – Location for Measurement

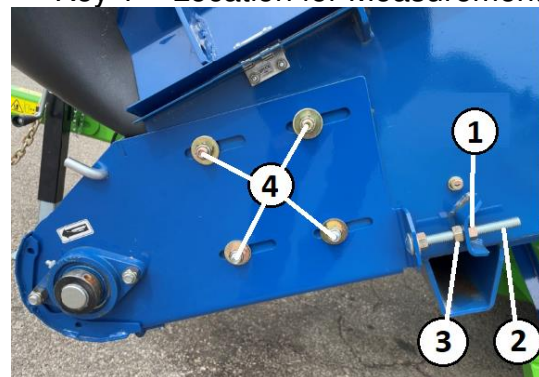

Figure 119. Chain Tension Adjust
 Key 1 – Jam Nut Key 2 – Adjusting Bolt
 Key 3 – Adjust Nut Key 4 – Retainer Nuts

Forage Distributor Position



WARNING:
DO NOT lubricate, adjust and/or service this Ag-Bagger unless the *Power Shut Down Procedure* in the *Safe Operation of Machine* section of this manual has been exercised.

The forage distributor is adjustable as to the clearance height between the distributor and the rotor.

The forage distributor must always remain level and parallel to the rotor.

The factory setting for the forage distributor is in the lowest position.

In general, the forage distributor should not need to be adjusted.

To adjust the distributor, first loosen the bearing lock collar at the drive end behind the oil tank. This is to prevent side-load on the bearings after adjustment.

Loosen the four bolts at each bearing for the distributor.

Move the distributor to the desired location and ensure that it is level and parallel to the rotor.

Tighten the bolts properly. Rotate the distributor by hand a few turns to ensure there is no side load on the shaft.

Reinstall the lock collar with two mallet taps in the same direction as rotation (clockwise from the motor end) and tighten the set screws properly. See Figure 120.

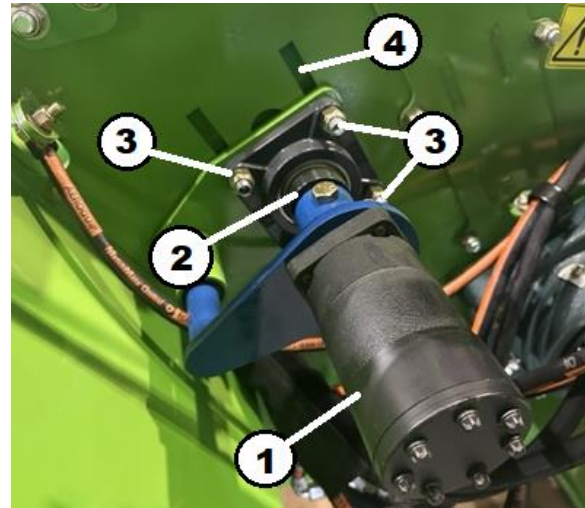

Figure 120. Distributor Adjustment
Key 1 – Motor Key 2 – Lock Collar
Key 3 – Bolts Key 4 – Slots



DANGER:
DO NOT operate the Ag-Bagger unless all guards are in place. Failure to do so may cause serious injury or death.

Rotor Drive Chain



WARNING:
DO NOT lubricate, adjust and/or service this Ag-Bagger unless the *Power Shut Down Procedure* in the *Safe Operation of Machine* section of this manual has been exercised.

The tensioner for the rotor chain is spring loaded.

Check the tensioner is maintaining proper tension on the chain.

Remove the rotor drive chain shield under the conveyor.

Adjust the spring tension to specification.

SPECIFICATION:
 Rotor Drive Chain Spring Tension Gap
 0.040 to 0.060 inch (1 to 1.5 mm)

To adjust the spring tension, loosen the lower jam nut on the threaded rod.

Turn the adjustment nut on the top side of the frame support until the specification is met.

Once set, tighten the lower jam nut properly. See Figure 121.

NOTE:

If a new tensioner is installed, set the spring tension to the high end of the specification, and check the tension after the first Ag-Bag is completed.

The tensioner used is a stationary plastic guide that does not rotate during operation. The chain will wear into this guide quickly until the rollers of the chain contact the plastic.

If the chain “slaps” during operation, increase the tension up to a maximum of 0.080 inch (2 mm) for the crop conditions that are causing the condition.

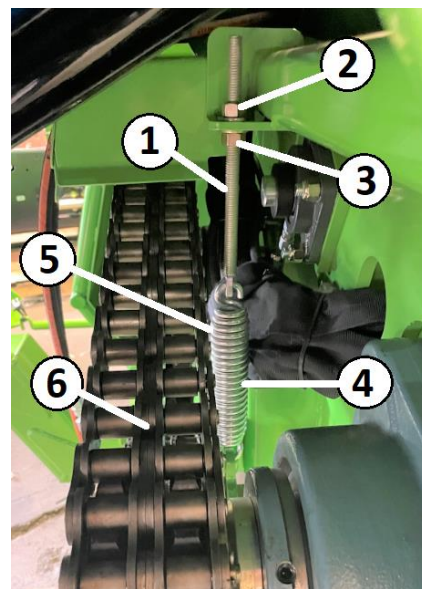

Figure 121. Rotor Drive Chain Tension
 Key 1 – Threaded Rod
 Key 2 – Adjuster Nut Key 3 – Jam Nut
 Key 4 – Spring Gap Location
 Key 5 – Spring Key 6 – Chain
 (Shield removed for clarity.)



DANGER:
DO NOT operate the Ag-Bagger unless all guards are in place. Failure to do so may cause serious injury or death.

Bag Boom



WARNING:
DO NOT lubricate, adjust and/or service this Ag-Bagger unless the *Power Shut Down Procedure* in the *Safe Operation of Machine* section of this manual has been exercised.

The bag boom is adjustable for height, handle position and pulley position. The boom can be adjusted down to rest the tube on top of the bag cradle for transport.

When in use, it can be adjusted up to allow for better handling of the bag cradle and tunnel extension.

Typically, higher bag boom positions will allow for easier handling of attachments.

Adjust the turnbuckle to adjust the bag boom. Do not overextend the turnbuckle in adjustment beyond the specification.

SPECIFICATION:

Bag Boom Turnbuckle Maximum Length
 (Measured pin-center to pin-center,
 Figure 122, Key 2) 31" (78 cm)

The pulley is aligned to the center of the bag cradle when in Ag-Bagging position.

Typically, the pulley will be in the end hole for larger tunnels and the first or second inside. The pulley is adjusted by using the cross pin and selecting a hole.

The handle is also adjustable and serves as a locking device for the bag boom in transport position by locking into a position on the frame. Use the cross pin at the handle to secure the handle up or down.

Always keep the hook of the cable attached to the machine and the cable tensioned for transport. Secure any loose components to the machine properly in transport.

Be aware of bystanders during operation and adjustment of the bag boom.

IMPORTANT:

1. Do not adjust the bag boom under load.
2. Do not overextend the turnbuckle.
3. Do not climb on machine to adjust the bag boom. With the help of an assistant, safely use a step ladder to access the components.
4. When adjust the turnbuckle, lock the part in place with the locking plate.

Failure to do so may result in machine damage or personal injury.

See Figure 122.

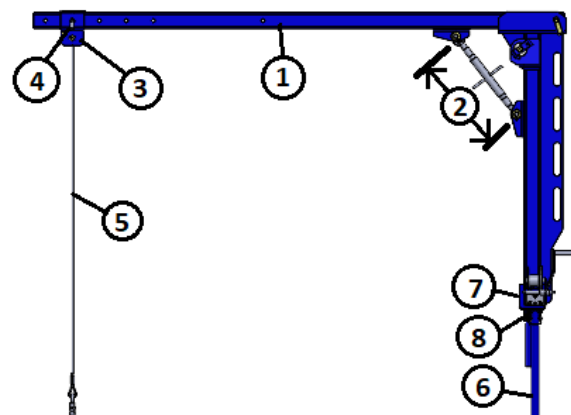

Figure 122. Bag Boom
 Key 1–Boom Key 2–Turnbuckle Length
 Key 3 – Pulley Key 4 – Pulley Cross Pin
 Key 5 – Cable Key 6 – Handle
 Key 7 – Winch Key 8 – Handle Pin

Bag Cradle



WARNING:
DO NOT lubricate, adjust and/or service this Ag-Bagger unless the *Power Shut Down Procedure* in the *Safe Operation of Machine* section of this manual has been exercised.

The bag cradle wings are adjustable for different sizes of tunnels.

The bag cradle performs best when it rests on the curvature of the tunnel when in the storage position.

To adjust the bag cradle, remove the lower bolt of the chain and adjust to take up chain slack when the bag cradle is resting on the tunnel.

When on an extension, the cradle will sit on top of a tube and the wings need to rest on the tunnel extension sheet metal to reach the hook points to move the extensions.

The chain can be moved between different links at the mounting bolt. In addition, two mounting holes are provided to take up the distance of a half link in the chain.

Install the chain with slack removed, but no tension on the chain.

Install the bushing between the chain and the cradle wing.

Tighten all hardware properly.

See Figure 123.

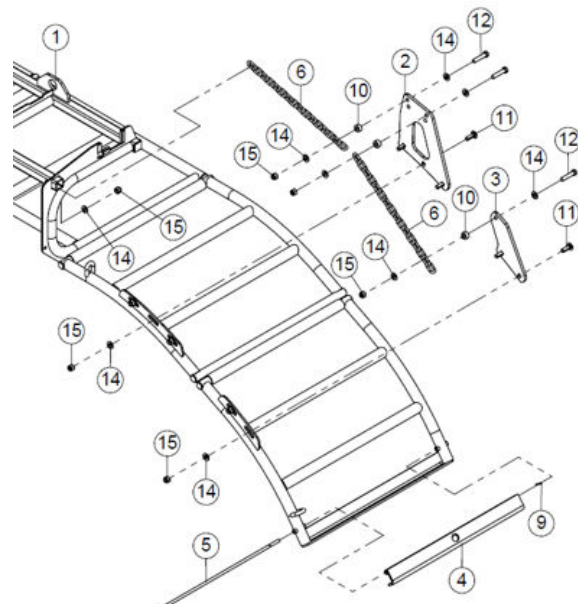

Figure 123. Bag Cradle Adjustment
Key 1 – Cradle Key 2 – Bracket
Key 6 – Chain Key 10 – Bushing
Key 12 – Bolt Key 15 - Nut

Tunnel Cleanout and Stripper Plate



WARNING:

DO NOT lubricate, adjust and/or service this Ag-Bagger unless the *Power Shut Down Procedure* in the *Safe Operation of Machine* section of this manual has been exercised.



DANGER:

DO NOT operate the Ag-Bagger unless all guards are in place. Failure to do so may cause serious injury or death.

The stripper bar plate and cleanout door are accessible when the tunnel cleanout door is in the open position. Refer to *Tunnel Cleanout Operation* section in this manual.

Before performing any work in this area, disconnect the PTO from both the tractor and the gearbox and place it in the storage position near the storage compartment towards the rear of the machine.

Stripper Bar Plate to Rotor Clearance

The stripper bar plate to rotor clearance is adjustable using shims at the cleanout door.

To adjust, loosen the nuts on the carriage bolts that secure the shims to the cleanout and the stripper plate to the cleanout, only at the locations where the shims are positioned.

Add or remove shims to adjust clearance to specification. Adjust all shims evenly.

SPECIFICATION:

Rotor to Stripper Bar Plate Clearance
1/2 inch (13mm) from tooth to tube

See Figure 124 and 125.

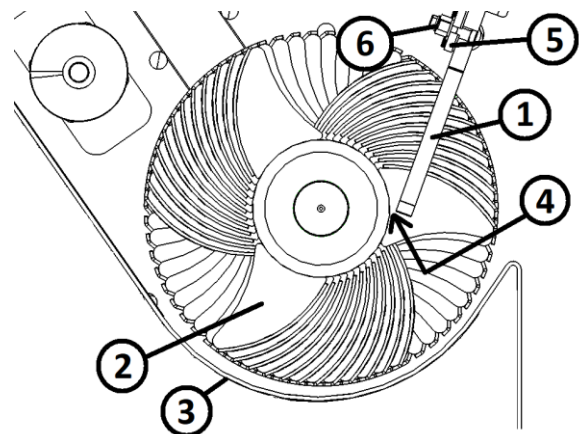

Fig. 124. Stripper Bar Plate Clearance
Key 1–Plate Key 2–Rotor Key 3–Floor
Key 4 – Clearance Location
Key 5 – Shims Key 6 – Nut

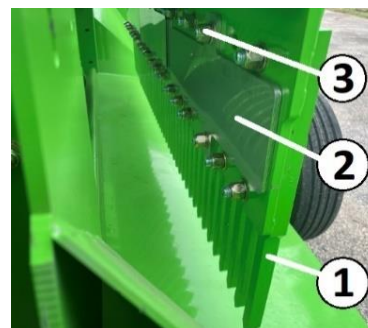

Figure 125. Stripper Bar Plate Shim
Key 1–Plate Key 2–Shim Key 3–Nut

Cleanout Door to Frame Clearance

The cleanout door can be adjusted side-to-side to fit tightly in the frame and to fine-tune the stripper bar plate alignment.

The cleanout door should be adjusted using the provided shims before adjusting the stripper bar plate for tooth alignment. To adjust the cleanout door to the frame, add or remove shims at each end of the door at the guides.

Install shims as needed to have a tight fit at the cleanout door with less than .040" (1mm) lateral movement when in the closed position. See Fig. 126 and 127.

Stripper Bar Plate Tooth Alignment

The stripper bar plate must be aligned relative the rotor to allow for proper tooth clearance.

This adjustment is typically made when replacing the stripper plate or rotor tine caps. The rotor should clear the stripper bar plate without excessive contact that could cause wear or machine damage. Grinding of tine caps may be necessary during replacement to clear the stripper plate.

To adjust the stripper bar plate, loosen the carriage bolts at the plate and adjust the stripper plate side-to-side as needed.

Rotate the rotor by hand slowly (with PTO disconnected as outlined on previous page) and ensure that the rotor clears the stripper bar plate as desired.

Tighten all hardware properly. See Figure 128.

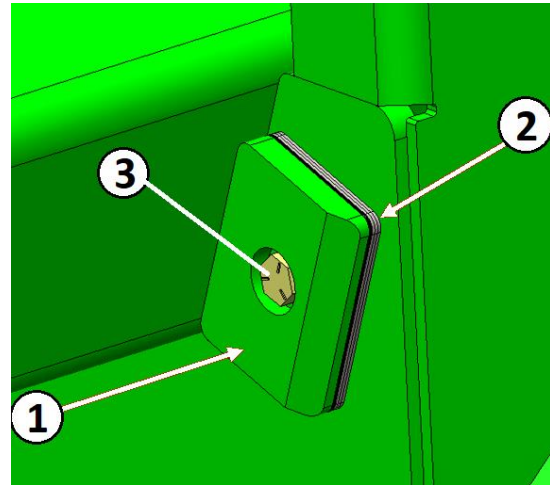

Figure 126. Cleanout Door Guide
Key 1–Guide Key 2-Shim Key 3-Bolt

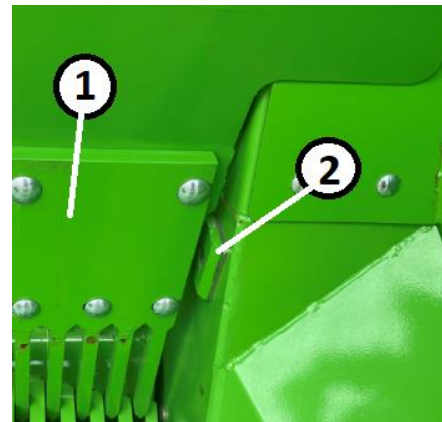

Figure 127. Guide Location
Key 1 – Plate Key 2 – Guide

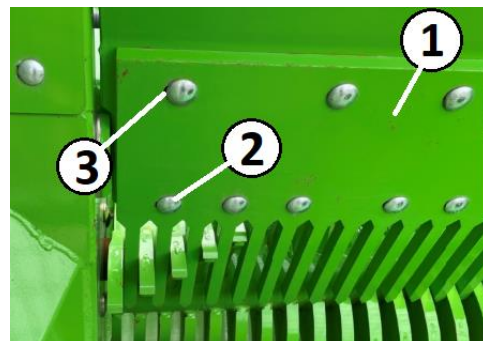

Figure 128. Stripper Plate Adjust
Key 1 – Plate Key 2 – Bolt Key 3 - Slot

Brake System Accumulator Pressure

The brake system features two accumulators to absorb impact loads and thermal expansion effects on the braking system.

The accumulator has a pre-set pressure of 1250 psi (8,620 kPa) at 70 deg F (21 deg C).

The accumulators should only be charged by a dealership using the proper equipment.

Be careful around this accumulator and take precautions when working on the unit around this accumulator.

See Figures 129 and 130.

Changing Tunnels

When changing tunnels, the tunnels must be unbolted from the tunnel cleanout structure.

To access this hardware, remove the access panel inside the tunnel, if equipped.

If not equipped, the bolts are accessible from the outside of the tunnel.

The tunnels also feature fork pockets for ease of removal.

Before operation, ensure all parts are installed and hardware tightened properly.

See Figure 131 and Repair Parts Pages for more information.



Figure 129. Accumulator Location (1)
Key 1 – Accumulator

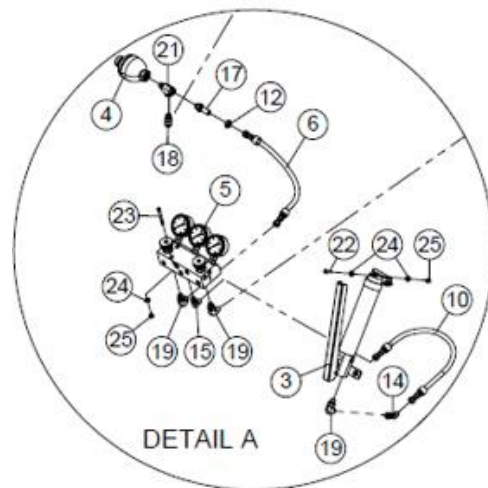

Figure 130. Accumulator Location (2)
Key 4 - Accumulator

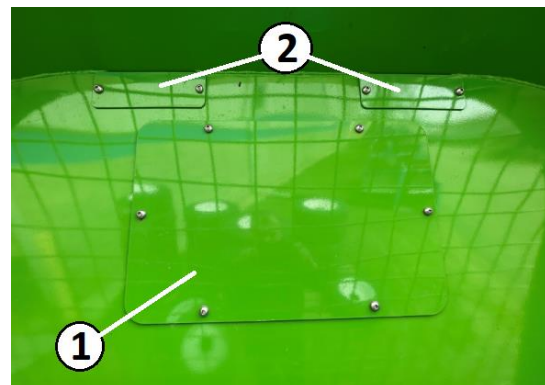

Figure 131. Tunnel Change Access
Key 1 – Cleanout Frame Access
Key 2 – Fork Pocket Covers

11 LUBRICATION AND MAINTENANCE



WARNING:
DO NOT lubricate, adjust and/or service this Ag-Bagger unless the *Power Shut Down Procedure* in the *Safe Operation of Machine* section of this manual has been exercised.



DANGER:
DO NOT operate the Ag-Bagger unless all guards are in place. Failure to do so may cause serious injury or death.

Tire Air Pressure

Interval: Daily

Check and maintain proper tire air pressure. Check pressure daily. Maintain tire air pressure per specification.

SPECIFICATION:

Tire Air Pressure (235/75R17.5)
130 psi (900 kPa) Cold

Tires are rated for 6,000 lbs. (2722 kg).

If alternate tires are used, follow the manufacturer's rating on the sidewall of the tire.

Wheel Lug Nut Torque

Interval: When new, after every 10 miles until torque stabilizes. Then, check monthly. Torque each wheel lug nut per the specification.

SPECIFICATION:

Wheel Lug Nut Torque
5/8" Wheel Studs – 170 ft-lbs.
(230 Nm)

Wheel Bearings - Repack

Interval: Annually for non-highway use. For highway use, check wheel bearings monthly. Repack wheel bearings annually.

Use a premium grade of lithium base wheel bearing grease.

Start with carefully raising and supporting each wheel as repacking is performed.

Remove the hub from the spindle and wipe old grease from all components. Inspect the inner and outer cups in the hub for signs of wear.

Pack the cones with clean grease. A pressure grease packer is recommended.

To hand pack cones, force grease under cage between rollers from large end of rollers until grease shows at the small end.

Fill the hub with clean grease to inner diameter of the cup race.

Place cone into the cup. Be certain that the cone is straight.



WARNING:
Failure to correctly lubricate bearing and maintain proper lubrication may result in bearing damage which could cause the wheel to lock and fail during operation.

Install new grease seal. Support the seal so as not to bend the case during installation.

Use grease to lubricate the seal lip.

Place the hub on the spindle. Rotate the hub while performing this step so that the seal lip does not fold under as the lip is installed on the seat of the spindle.

Fill hub cavity with grease.

Place the outer cone on the spindle and into the cup.

Assembly the nut onto the spindle and tighten the nut to 15-20 ft-lbs. (20-27 Nm) while rotating the hub.

Back off the nut until wheel rotates with a slight drag.

Bend at least one of the washer tabs up and into a slot in the nut.

There should be approximately 0.001 to 0.005 inches (0.0254 to 0.1270 mm) of end play.



WARNING:
Failure to back off adjusting nut may cause bearing to heat during operation and may damage the bearing, which could cause the wheel to lock and fail during operation.

Grease inside of dust cover and install dust cover.

Lower wheel to ground and repeat for other wheel.

IMPORTANT:
When using a battery-operated or air-powered grease gun, use the lowest pressure setting on the gun and take care to not damage the plastic grease lines used between the grease fittings and the bearings.

Wheel Bearings - Greasing

Each set of wheel bearings is greased at the hub.

Interval: Daily if towed on highway. Monthly for on-farm use.

Locate the grease fitting on the wheel hub. See Figure 132.

Use a premium grade of lithium base wheel bearing grease.

Wipe off each fitting before attaching the grease gun. Grease each wheel bearing assembly. Wipe off excess grease when finished.

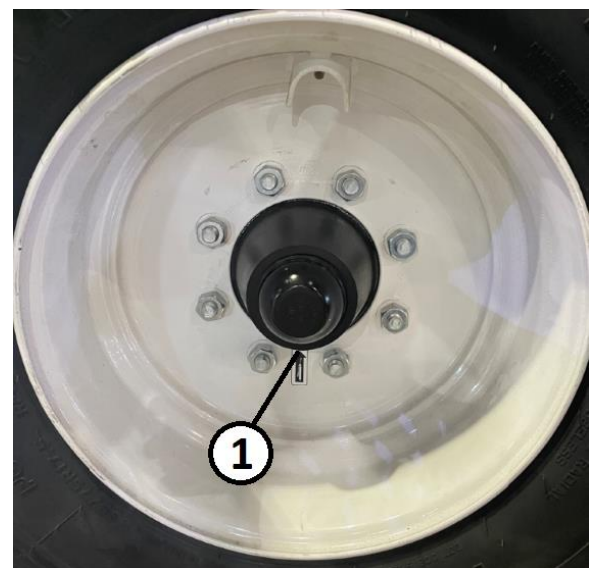

Figure 132. Grease Fitting Location
Key 1 – Grease Fitting

Rotor Bearings

Interval: Every 2 hours of Ag-Bagging.

Each rotor bearing is greased by using a remote mounted grease fitting at the operator station.

The two grease fittings are the first two fittings, numbers 1 and 2, in the row closest to the operator and are indicated with a red circle on the decal to indicate they are a high duty grease cycle.

Wipe off each fitting before attaching the grease gun. Wipe off excess grease when finished.

Grease each rotor bearing with 5 pumps of grease gun from the manual grease gun provided at each interval.

See Figure 133.

Rotor Drive Jackshaft Bearings

Interval: Once per Ag-Bag

Each jackshaft bearing is greased by using a remote mounted grease fitting at the operator station.

The two grease fittings are the middle grease fittings, numbers 3 and 4, in the row and are indicated with an orange circle on the decal to indicate they are a medium duty grease cycle.

Wipe off each fitting before attaching the grease gun. Wipe off excess grease when finished.

Grease each jackshaft bearing with 5 pumps of grease gun from the manual grease gun provided at each interval. See Figure 133.

Forage Distributor Bearings

Interval: Once per Ag-Bag

Each distributor bearing is greased by using a remote mounted grease fitting at the operator station.

The two grease fittings are located the furthest away, numbers 5 and 6, in the row of fittings and are indicated with a yellow circle on the decal to indicate they are a low duty grease cycle.

Wipe off each fitting before attaching the grease gun. Wipe off excess grease when finished.

Grease each distributor bearing with 2 pumps of grease gun from the manual grease gun provided at each interval.

See Figure 133.



Figure 133. Grease Bank
 Key 1 and 2 – Rotor Bearings
 Key 3 and 4 – Jackshaft Bearings
 Key 5 and 6 – Distributor Bearings

Conveyor Bearings

Interval: Daily

The conveyor has four bearings and that require greasing.

Three bearings are greased through a fitting on the bearing housing.

The top inside bearing is greased through a remote mounted grease fitting

Wipe off each fitting before attaching the grease gun.

Wipe off excess grease when finished.

See Figures 134 and 135.

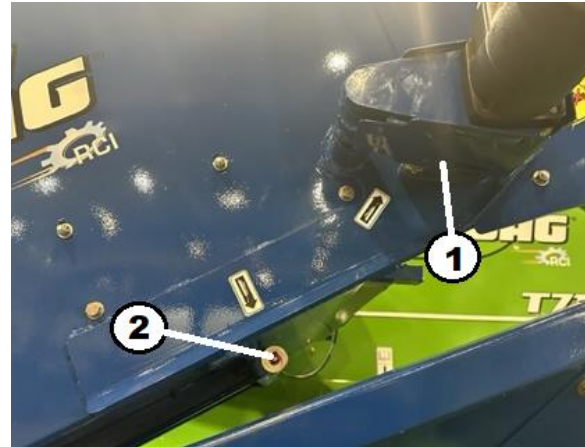

Figure 134. Upper Bearing Greasing
Key 1 – Outer Bearing Grease Fitting
Key 2 – Inner Bearing Grease Fitting

Conveyor Slides

Interval: Annual

The conveyor has four conveyor slide grease fittings and that require greasing.

Two fittings are located at each side of the conveyor.

Wipe off each fitting before attaching the grease gun.

Wipe off excess grease when finished.

See Figure 136.

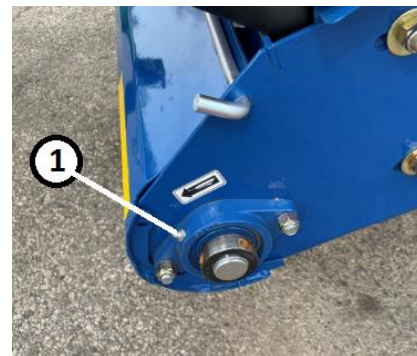

Figure 135. Lower Bearing Greasing
Key 1 – Grease Fitting



Figure 136. Conveyor Slide Greasing
Key 1 – Lower Slide Grease Fitting
Key 2 – Upper Slide Grease Fitting
Note: Outer fittings shown.
See back side for other 2 fittings.

Conveyor Cleanout

Interval: Daily

The conveyor has a lower hopper pan for cleanout to allow the removal of any material accumulated.

Remove the hitch pin clip and the rod to allow the pan to open.

Clean out all accumulated material to prevent damage to components and attraction to rodents.

Close and secure the door with pin and clip before operating.

See Figures 137 and 138.



DANGER:
DO NOT operate the Ag-Bagger unless all guards are in place. Failure to do so may cause serious injury or death.

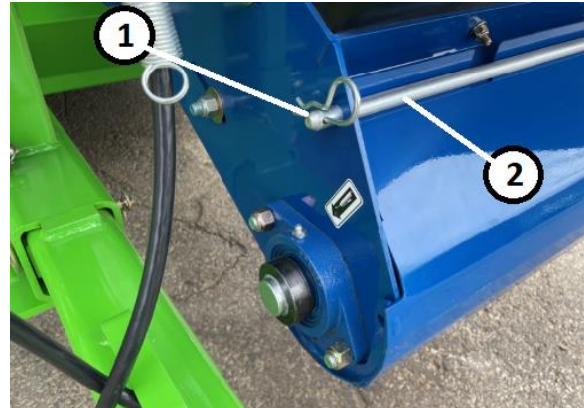

Fig. 137. Conveyor Cleanout Hardware
Key 1 – Hitch Pin Clip Key 2 – Rod



Figure 138. Conveyor Cleanout Open
Key 1 – Conveyor Cleanout Door

Manual Jacks

Interval: Monthly

The two (2) manual jacks are equipped with a grease fitting near the crank.

Wipe off the grease fittings before attaching the grease gun.

Grease each fitting. Wipe off excess grease when finished.

See Figure 139.



Figure 139. Manual Jack
Key 1 – Fitting Location

Rotor Drive Chain

Interval: Every 2 hours of Ag-Bagging.



DANGER:
DO NOT operate the Ag-Bagger unless all guards are in place. Failure to do so may cause serious injury or death.

With the Ag-Bagger idling, oil the rotor drive chain through the oil slot located in the cover over the rotor drive chain.

Oil drive chain well using SAE 30 oil.

Alternatively, if the unit is turned off with the *Power Shut Down Procedure* in the *Safe Operation of Machine* section of this manual, the chain can be lubricated by removing the main shield or through the inspection hole behind the round access cover.

See Figures 140 and 141.

Jackshaft Coupler Chain

Interval: Every 2 hours of Ag-Bagging.



DANGER:
DO NOT operate the Ag-Bagger unless all guards are in place. Failure to do so may cause serious injury or death.

With the Ag-Bagger idling, oil the jackshaft coupler chain through the oil slot located in the cover over jackshaft, nearest the decal. Oil coupler chain well using SAE 30 oil. The oil bottle can be stored in the bracket by the operator station.

See Figure 142.



Figure 140. Rotor Drive Chain Oiling
 Key 1 – Oiling Slot
 Key 2 – Drive Cover
 Key 3 – Inspection Hole

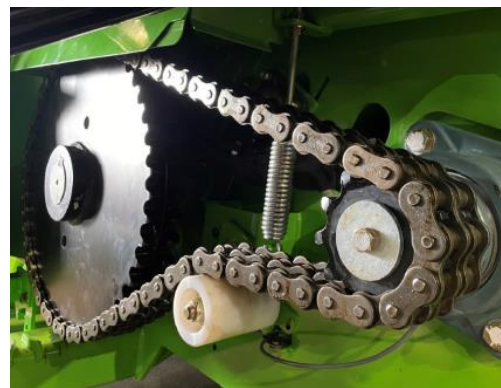

Figure 141. Rotor Chain

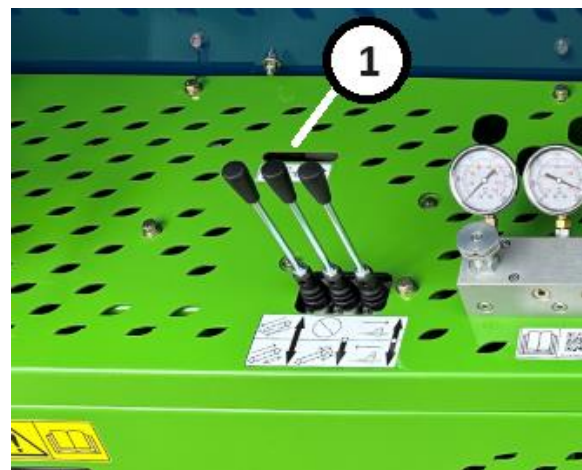

Figure 142. Jackshaft Oiling
 Key 1 – Oil Slot

PTO Shaft



DANGER:
DO NOT operate the Ag-Bagger unless all guards are in place.

Failure to do so may cause serious injury or death.

Interval: Daily

Wipe off the grease fittings before attaching the grease gun.

Grease each u-joint and the shear plates.

Wipe off excess grease when finished.

Apply a coating of grease to the slide tube inside the PTO shaft at a monthly interval.

See Figure 143.

Bag Boom Pivot

Interval: Monthly

Wipe off the grease fittings before attaching the grease gun.

Grease fitting and swing the bag boom side to side to distribute the grease evenly.

Do not over grease as the pivot tube is open to the bottom side.

Wipe off excess grease when finished.

See Figure 144.

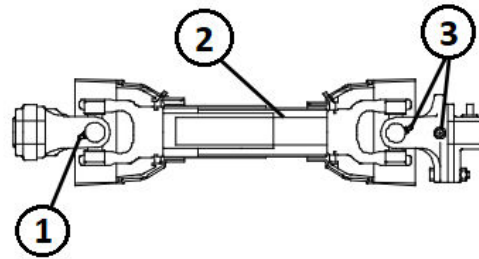

Fig. 143. PTO Shaft Grease Locations
Key 1 – U-Joint Key 2 – Slide Tube
Key 3 – U-Joint and Shear Plate



Figure 144. Boom Pivot Greasing
Key 1 – Grease Fittings

Anchor Position Control

DANGER:

DO NOT operate the Ag-Bagger unless all guards are in place. Failure to do so may cause serious injury or death.

Interval: Monthly

Wipe off the grease fittings before attaching the grease gun.

Note: Early models have grease fittings in the upper location. Later models are located at the bottom of the panel.

See Figures 145 and 146.

Open the access panel to the anchor position control. Locate three (3) grease fittings at the tensioner and pulley on the cylinder. See Figure 147.

At the anchor supports, locate a grease fitting at each of the two (2) pins on each support. See Figure 148.

Grease each fitting. Wipe off excess grease when finished.

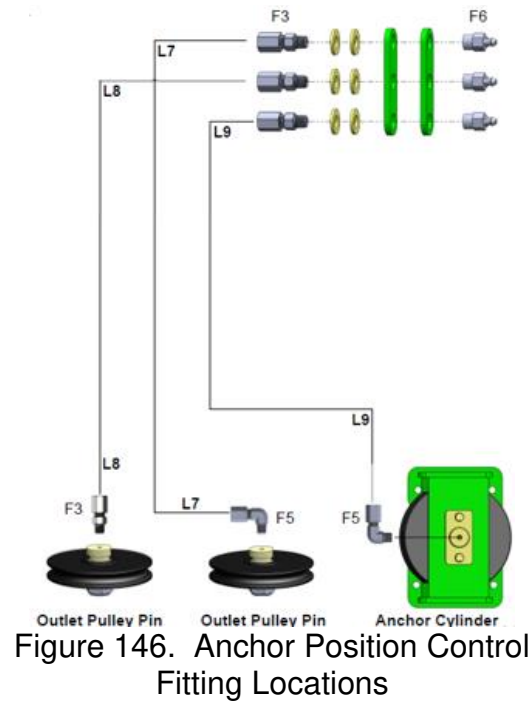

Figure 146. Anchor Position Control Fitting Locations



Figure 147. Cabinet Grease Fittings
Key 1 – Fitting Locations



Figure 145. Anchor Position Control Greasing
Key 1 – Fitting Locations (ref)

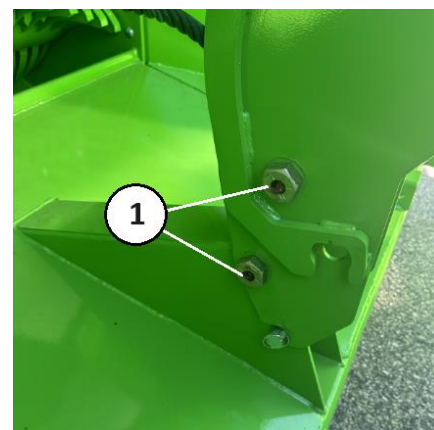

Figure 148. Anchor Support Fittings
Key 1 – Fitting Locations

Hydraulic Oil Level Check

Interval: Daily

Maintain the oil level in the main hydraulic oil reservoir at a point approximately in the middle to 2/3 of the level indicator at the side of the hydraulic reservoir.

The cap for the tank is a breather cap.

To fill the tank, clean the area around the breather cap, remove the cap, and proceed to fill the tank as needed.

The screen beneath the cap should always be used as a safety for large particles to be screened out of new oil. Clean as needed.

Use only oil that matches the specification.

SPECIFICATION:
Hydraulic Oil ISO Grade 68

Factory Fill: John Deere Hy-Gard

Estimated System Capacity:
22 gal (100 L)

See Figures 149 and 150.

NOTE:

The oil level gauge also has a thermometer built into the side.

When operating, normal operating temperature may be as high as 180 deg F (82 deg C).

Do not allow system to heat to over 200 deg F. If over 200 deg F (93 deg C), shut off the system and allow the temperatures to cool.

Keep the hydraulic reservoir clean to maximize the heat transfer from the reservoir for cooling.

Make sure all components are functioning properly and maintain proper adjustments for all areas outlined in this manual.

It is also best to shut off the PTO when waiting for loads to minimize the heat load on the driveline and the hydraulics.



Fig. 149. Hydraulic Oil Reservoir Level
Key 1 – Hyd. Oil Level Gauge



Fig. 150. Vented Hyd. Reservoir Cap
Key 1 - Cap

Hydraulic Oil Change

Interval: Every 250 hours

The most important element in maintaining hydraulic oil is to keep it clean, filtered and do not allow it to overheat.

Clean, filtered oil is tan colored. If properly maintained, it is usable for a long period of time.

Because it is possible to encounter contamination and possible high temperature applications, it is recommended that the oil be changed every 250 hours of operation.

Any time the oil is changed, the hydraulic oil filter should also be changed.

See *Hydraulic Oil Filter Change* in this section.

If the oil color turns dark brown or black, it is burned from overheating.

If it is “milky” in coloring prior to use, it is contaminated or has taken on moisture. Some “milky” appearance can occur during use depending on the operation conditions.

If either of these conditions are observed, the oil and filter must be changed regardless of the time interval.



WARNING:
Allow hydraulic oil and reservoir to cool prior to proceeding.
Hot hydraulic oil can cause severe burns.

Place a suitable container (capable of holding 25 gallons (114 L) under the plug at the bottom of the hydraulic reservoir.

Remove the drain plug from the bottom of the tank to drain the hydraulic reservoir.

Allow the tank to drain completely.

Clean and reassemble the drain plug to the hydraulic reservoir.

See Figure 151.

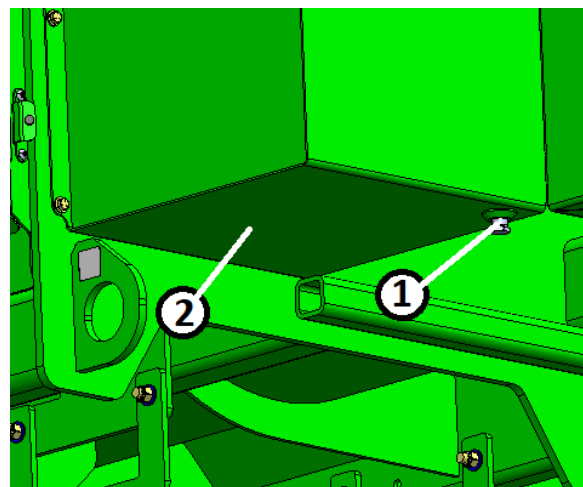

Figure 151. Hydraulic Reservoir Drain
 Key 1 – Drain Key 2 - Reservoir

Hydraulic Oil Filter

Interval: Annually and whenever hydraulic oil is changed

The oil filter is located inside the service compartment, near the hydraulic pump and reservoir.

After the unit is turned off with the *Power Shut Down Procedure* in the *Safe Operation of Machine* section of this manual, the system should be allowed to cool.

Open the service door near the storage compartment side of the machine.

Thoroughly clean the area around the hydraulic oil filter head.

Remove the oil filter from the filter head.

Clean the sealing surface of the filter head.

Lightly oil the gasket on the new filter.

Fill the filter with new hydraulic oil and spin on to the filter head.

Hand-tighten the filter to initial contact, then tighten an additional $\frac{3}{4}$ turn.

Replacement oil filters are available from your Ag-Bag dealer by ordering part number AA1540167.

See Figure 152.

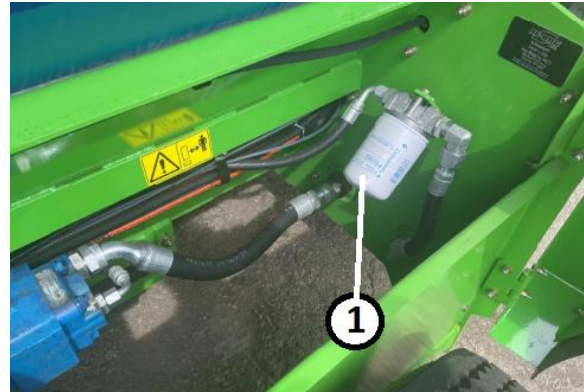

Figure 152. Oil Filter Location
Key 1 – Oil Filter

Gearbox and Planetary Oil

Interval: Annual or whenever hydraulic oil is changed



WARNING:
DO NOT lubricate, adjust and/or service the Ag-Bagger unless the *Power Shut Down*

***Procedure in the Safe Operation of Machine* section of this manual has been exercised.**

IMPORTANT:

The Planetary gearbox is filled with Mobil SHC Gear 220 Synthetic Oil from the factory. The approximate capacity of the gearbox is approximately 1.85 gal. (7 L). Always fill to the center of the sight glass at the right-angle gearbox after running to normalize oil levels. DO NOT mix different oils.

SPECIFICATION:

Gearbox Oil

Mobile SHC Gear 220 Synthetic Oil
Approx. 1.85 Gal (7 L)

The right-angle gearbox and planetary share a common sump and are open between them through a bearing on a shaft only. Therefore, whenever filling with oil, it is very important to allow the oil level to normalize between the two after running and warm, and to verify the resulting oil level before applying a load to the machine.

This fill procedure is based on the idea of adding oil to each side of the assembly and then verifying the resulting oil level using the single sight glass on the right-angle gearbox.

Rotate the cover over the top of the gearbox to expose the fill port and breather on top.

Place a suitable container under the drain plugs located on the bottom of the gearbox and planetary.

Remove the plugs and allow all oil to drain from the gearbox and planetary. See Figure 153.

After all oil is drained, replace the drain plugs and tighten securely.

The fill holes are indicated in Figure 153.

Only one fill plug is needed to be used on the planetary and one at the top for the gearbox.

Remove any one fill plug of the planetary. Using a small hose on the oil bottle, add oil to the planetary AND gearbox as outlined below.

Fill the planetary first with approximately 1 gallon (4 L) of the specified gear oil. Install the plug and tighten properly. The remaining oil will be added to the right-angle gearbox.

On the top side of the right angle gearbox, locate the fill plug as indicated and remove.

Fill the right angle gearbox with approximately $\frac{3}{4}$ gallon (3 L) of the specified gear oil. Install the plug.

Close all shields and run the machine at idle for 5 minutes. Follow all safety precautions in this manual and in the tractor manual.

Shut off the unit following the *Power Shut Down Procedure* in the *Safe Operation of Machine* section in this manual. Wait 5 minutes for the oil in the system to settle.

Inspect the oil level at the sight glass. If low, top off the oil in the right-angle gearbox to the top of the sight glass and repeat the process. The planetary side does not need to be topped off.

Repeat the operation of the machine for 5 minutes and repeat the process until the oil level is in the middle of the sight glass after settling.

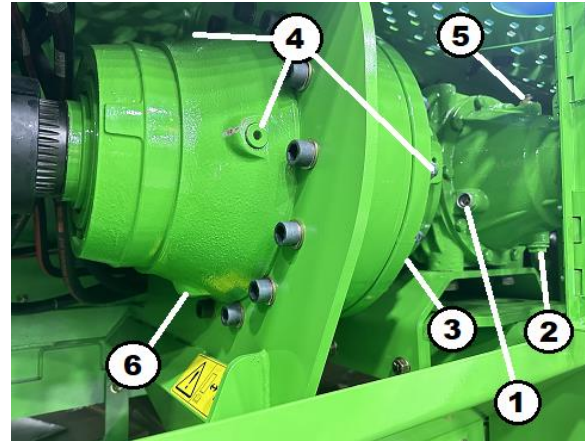

Figure 153. Gearbox and Planetary Oil

- Key 1 – Sight Glass
- Key 2 – Right-Angle Gearbox Drain
- Key 3 – Planetary Drain
- Key 4 – Planetary Fill (Use any)
- Key 5 – Right-Angle Gearbox Fill
- Key 6 – Do Not Use

Brake Pads

The brake pads can be removed without removing the wheel, or brakes. There is a pin at the pad that can be removed to allow the pads to be slipped out of the assembly on the machine, while pressure is released.

See repair parts pages for more information.

Cables



WARNING:
DO NOT lubricate, adjust and/or service the Ag-Bagger unless the *Power Shut Down Procedure* in the *Safe Operation of Machine* section of this manual has been exercised.

Interval: Once Per Ag-Bag

IMPORTANT:
ALWAYS wear gloves when handling or working with cables.

Check the cables at the end of each Ag-Bag when the cables are visible in the cabinet with the door open.

Check each cable for frayed spots, kinks, broken strands, or thin spots.

Check the cable ends making sure the cable is not pulled from the sleeve.

If any damage to a cable is found, replace the cable before using the machine again.

IMPORTANT:
Only use Genuine Ag-Bag parts. Failure to do so may result in unintended consequences.

PTO Shear Bolts

Interval: As Required

IMPORTANT:
NEVER replace a shear bolt with one that is a different size or grade.

If the shear bolt in the PTO shaft should break, spare shear bolts are stored under the cover for the storage compartment.

When installing a new shear bolt, tighten the shear bolts properly.

Always close and secure the cover over the storage compartment before using the Ag-Bagger.

See Figure 154.

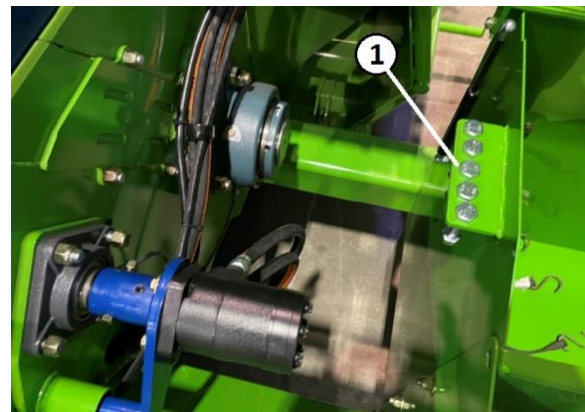

Figure 154. Shear Bolt Storage Location
Key 1 – Shear Bolt Storage

Brake System Oil

Interval: As Required

If the hand pump is low on oil and does not maintain the ability to pump correct pressure, the reservoir on the pump needs to be refilled.

IMPORTANT:

Only use hydraulic jack oil in the hand pump. DO NOT use brake fluid in this system. Brake fluid will cause the seals to deteriorate and the hand pump to fail.

Before refilling, release any pressure in the brake system by opening the needle valves. Remove the filler plug.

Fill the pump with hydraulic jack oil to within approximately 1" (25 mm) of the bottom edge of the filler hole.

It may be easiest to use a camera phone to take a picture of inside of the hand pump. Alternatively, use a clean object as a dipstick to check the oil level due to location. Take care to keep foreign material out of the pump.

Install the fill plug. Bleed air from the pump chamber by opening pump valve (turning knob counterclockwise) and pumping the handle about 20 times.

Bleed the air from the brake system using the bleeders at the calipers.

Close the pump valve, open the needle valve, open the bleeders, and operate the pump until all air is purged from the system. Close the bleeders and the valves.

Check the oil level in the pump reservoir.

NOTE: As the brake pads wear, the oil level in the hand pump will decrease.

When new brake pads are installed and the calipers compressed to fit the new brake pads, hydraulic jack oil may need to be removed from the reservoir of the hand pump.

NOTE:

Do not overfill the hand pump. An air pocket is required for the pump to work properly.

Apply a quality grade of grease to all pivot and rubbing points on the pump. Do not use dry lubricants.

NOTE:

The braking system uses two accumulators to allow the brake system pressure to be more stable with fluctuations of temperature. Pumping to increase pressure on systems with an accumulator will take more hand pumps to increase the pressure compared to other models without accumulators.

See Figure 155.

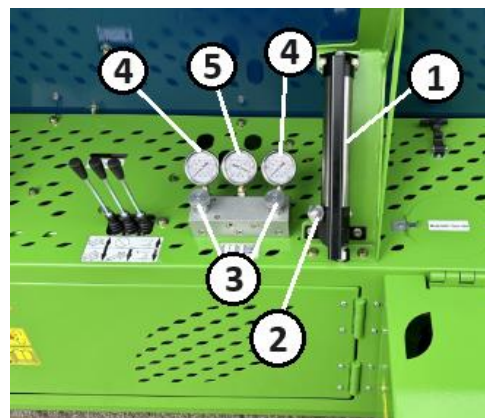

Figure 155. Brake System Control
 Key 1 – Hand Pump
 Key 2 – Pump Release
 Key 3 – Needle Valves and Lock Rings
 Key 4 – Brake Pressure Gauges

Rotor Tooth Tine Caps

Interval: As Required



WARNING:
DO NOT lubricate, adjust and/or service the Ag-Bagger unless the **Power Shut Down Procedure** in the **Safe Operation of Machine** section of this manual has been exercised.

Shut off tractor, place in Park, remove the key and remove the PTO shaft from the tractor AND the gearbox. Place PTO shaft into storage position near the storage compartment.

Periodically check the wear of the rotor tine caps.

Replace the caps if they show any of the following signs of wear:

- Cap is worn and pointed.
- Sides of cap are worn to leave more than 1/8" (3mm) gap between cap and stripper bar.
- Cap is bent or torn.
- Cap is missing.

To replace the cap, rotate the rotor by hand until the damaged or worn rotor cap is accessible from the tunnel side of the stripper bar.

Remove the existing rotor cap from the rotor tooth.

Clean up the rotor tooth.

Place the new rotor tooth cap on top of the rotor tooth. The cap should be centered in the space between the two stripper bars.

Check to ensure the cap is straight with the tooth and weld across both ends and in the slots of the cap.

NOTE:

If the space on either side of the new rotor tooth cap exceeds 1/8" (3mm), the stripper bar plate may need replacement. Contact your Ag-Bag dealer.

NOTE:

For removal of the caps, it may be easier to open the tunnel cleanout or to remove the stripper plate prior to beginning the work. Follow the appropriate sections of this manual for operation of the tunnel cleanout and stripper plate removal.

See Figure 156.



Figure 156. Rotor Tooth Tine Cap
 Key 1 – Cap Installed
 Key 2 – Stripper Bar Plate

Stripper Bar Plate

Interval: As Required

The stripper bar plate should be replaced whenever the gap between a new tine cap and the stripper bar plate exceeds 1/8" (3mm).

To replace the stripper bar plate, it is best to open the tunnel cleanout and remove the bolts of the stripper bar plate.

See the *Cleanout Operation* section of this manual for information regarding the operation of the tunnel cleanout.

When installing a new stripper bar plate, the cleanout guides, and the stripper bar plate must be properly adjusted for proper operation.

Refer to the *Tunnel Cleanout and Stripper Bar Plate* section in the *Adjustments* section of this manual.

NOTE:

Sections of the stripper bar plate can be replaced if needed. See parts pages for more details on the components. Worn or damaged sections can be cut out of the plate and a smaller section can be bolted in the assembly.

When installing a new stripper bar plate and adjusting, always tighten hardware properly and check clearance of the stripper bar plate to the rotor before Ag-Bagging.

See Figures 157 through 159.

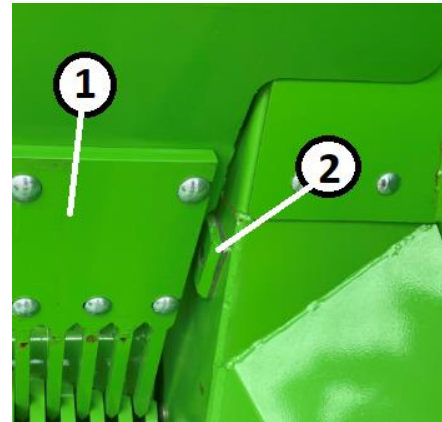

Figure 157. Guide Location
Key 1 – Plate Key 2 – Guide

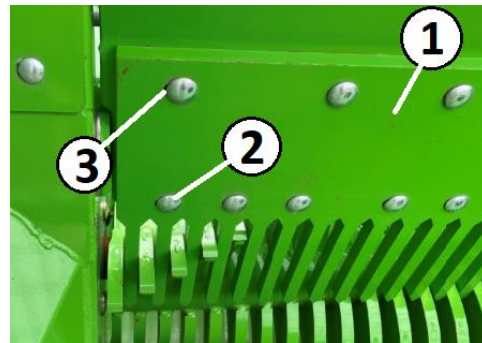

Figure 158. Stripper Bar Plate Adjust
Key 1 – Plate Key 2 – Bolt Key 3 – Slot

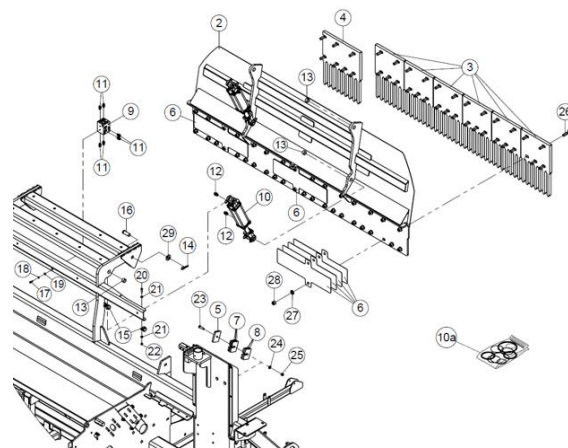

Figure 159. Stripper Bar Plate Parts

12 SERVICE

Torque Specifications

NOTE: Use these torque values when tightening hardware, excluding lock nuts, self-tapping screws, thread forming screws, and sheet metal screws unless otherwise specified. All torque values are in lb-ft except those marked with an (*) which are lb-in.

For metric torque value Nm, multiply lb-ft by 1.355 or for lb-in multiply by 0.113).







Unified National Thread	Grade 2 		Grade 5 		Grade 8 	
	Dry	Lubed	Dry	Lubed	Dry	Lubed
8-32	19*	14*	30*	22*	41*	31*
8-36	20*	15*	31*	23*	43*	32*
10-24	27*	21*	43*	32*	60*	45*
10-32	31*	23*	49*	36*	68*	51*
1/4-20	66*	50*	9	75*	12	9
1/4-28	76*	56*	10	86*	14	10
5/16-18	11	9	17	13	25	18
5/16-24	12	9	19	14	25	20
3/8-16	20	15	30	23	45	35
3/8-24	23	17	35	25	50	35
7/16-14	32	24	50	35	70	55
7/16-20	36	27	55	40	80	60
1/2-13	50	35	75	55	110	80
1/2-20	55	40	90	65	120	90
9/16-12	70	55	110	80	150	110
9/16-18	80	60	120	90	170	130
5/8-11	100	75	150	110	220	170
5/8-18	110	85	180	130	240	180
3/4-10	175	130	260	200	380	280
3/4-16	200	150	300	220	420	320
7/8-9	170	125	430	320	600	460
7/8-14	180	140	470	360	660	500
1-8	250	190	640	480	900	680
1-14	270	210	710	530	1000	740
Metric Course Thread	Grade 8.8 		Grade 10.9 		Grade 12.9 	
	Dry	Lubed	Dry	Lubed	Dry	Lubed
M6-1	8	6	11	8	13.5	10
M8-1.25	19	14	27	20	32.5	24
M10-1.5	37.5	28	53	39	64	47
M12-1.75	65	48	91.5	67.5	111.5	82
M14-2	103.5	76.5	145.5	108	176.5	131
M16-2	158.5	117.5	223.5	165.5	271	200

Figure 160. Torque Specification Chart

Hydraulic Fittings



WARNING:
Escaping fluid under pressure can penetrate the skin causing serious injury. Relieve pressure before disconnecting hydraulic or other lines. Tighten all connections before applying pressure. Keep hands and body away from pin holes and nozzles which eject fluids under high pressure. Use a piece of cardboard or paper to search for leaks. **DO NOT** use your hand to search for leaks.

Tightening O-Ring Fittings*

Inspect O-ring and seat for dirt or defects.

On angle fittings, loosen the lock nut until the washer bottoms out at top of groove.

Hand-tighten fitting until backstop washer or washer face (if straight fitting) bottoms on face and O-ring is seated properly.

Position angle fittings by unscrewing less than one turn.

Tighten straight fittings to torque indicated in the provided chart.

Tightening Flare-Type Fittings*

Check flare and flare seat for defects.

Align hose end with fitting prior to tightening.

Lubricate connection and hand tighten swivel nut until snug.

To prevent twisting the hose, use two wrenches. Place one wrench on the hose end body. With the second wrench, tighten the swivel nut to the torque indicated in the chart provided.

*Torque values shown are based on lubricated connections in reassembly.

Thread Size (In.)	Nut Size Across Flats (In.)	Torque Value*		Recommended Turns To Tighten (After Finger Tightening)	
		(Nm)	(lb-ft)	(Flats)	(Turns)
3/8	1/2	8	6	2	1/3
7/16	9/16	12	9	2	1/3
1/2	5/8	16	12	2	1/3
9/16	11/16	24	18	2	1/3
3/4	7/8	46	34	2	1/3
7/8	1	62	46	1-1/2	1/4
1-1/16	1-1/4	102	75	1	1/6
1-3/16	1-3/8	122	90	1	1/6
1-5/16	1-1/2	142	105	3/4	1/8
1-5/8	1-7/8	190	140	3/4	1/8
1-7/8	2-1/8	217	160	1/2	1/12

Figure 161. O-Ring Fitting Torque Chart

Tube Size OD (In.)	Nut Size Across Flats (In.)	Torque Value*		Recommended Turns To Tighten (After Finger Tightening)	
		(Nm)	(lb-ft)	(Flats)	(Turns)
3/16	7/16	8	6	1	1/6
1/4	9/16	12	9	1	1/6
5/16	5/8	16	12	1	1/6
3/8	11/16	24	18	1	1/6
1/2	7/8	46	34	1	1/6
5/8	1	62	46	1	1/6
3/4	1-1/4	102	75	3/4	1/8
7/8	1-3/8	122	90	3/4	1/8

Fig. 162. Flare-Type Fitting Torque Chart

Hydraulic System Pressure

SPECIFICATION

System Relief Pressure:
3,000 psi (20,685 kPa) maximum

Hand Control Manifold Pressure Relief Adjustment:

1. Locate the pressure relief cartridge on the control valve at the operator station (next to hand pump)

Note: The control valve at the tunnel cleanout and jack control has a relief valve as well, but it is set higher than the main relief valve to avoid confusion on the adjustment.

2. Use a 13mm wrench to remove the jam nut.
3. Use a 4mm Allen wrench to turn the adjustment screw.
 - a. As viewed from the front:
 - i. CW (turns screw in) increases the press.
 - ii. CCW (turns screw out) decreases the pressure
 - b. $\frac{1}{4}$ turn = approximately 100 PSI at rated speed
 - c. Pressure relief is set to 3000 PSI from the factory
4. Reinstall the jam nut

Make sure oil is above 100 deg F before testing pressure.

See Figures 163 and 164.

Test relief pressure by installing a pressure gauge on the pressure line from the pump and by bottoming out one of the hydraulic functions.

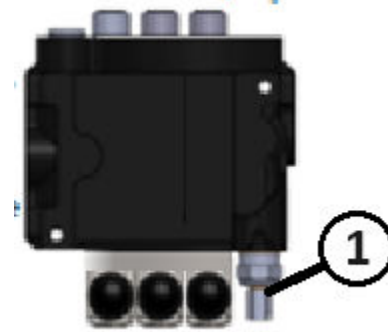

Figure 163. Pressure Adjustment
Key 1 – Relief Cartridge



Figure 164. Relief Valve Location
Key 1 – End of Valve

Lubrication Specifications

Planetary and Gearbox

Type: Mobile SHC Gear 220 Syn.
Capacity Approx. 1.85 Gal (7 L)

Hydraulic System

Type of Oil ISO Gr 68 Hyd. Oil
Capacity 22 gal (100 L)
Factory Fill John Deere Hy-Gard

Hand Pump

Type of Oil Hydraulic Jack Oil

Grease

Type: Gr. 2 Lithium Complex EP

Wheel Bearings

Type: Gr. 2 Lithium Complex EP

Rotor Chain

Type of Oil SAE 30

Jackshaft Coupler Chain

Type of Oil SAE 30

Hydraulic Pump Drive Chain

Type of Oil SAE 30

Anchor Cable Tension Lockout

The anchor position control system has a built-in tensioner to keep a light load on the cables when they are not under load from forage.

This tensioner can be locked out for service.

IMPORTANT:

The machine should never be operated for bagging with the anchor cable tensioner locked out. Machine damage may result.

Also, cables may become entangled if the tensioner is not operational, so it is

important to inspect the cables regularly.

Before moving the anchor position control, make sure the tunnel cleanout is closed and the cables are not in the storage position.

Follow procedures in this manual for operating these functions.

To lock out the cable, make sure the tunnel cleanout is closed and set the anchors to the Home position.

Remove the pin, slide the handle to the inside position, and reinstall the pin.

Extend the anchors out to Position 3 to remove the tension on the cables.

If extending to Position 6, take care that the cables do not bind in the control cabinet as the tension is not present to keep them aligned.

Follow procedures in this manual for operating these functions.

See Figure 165.

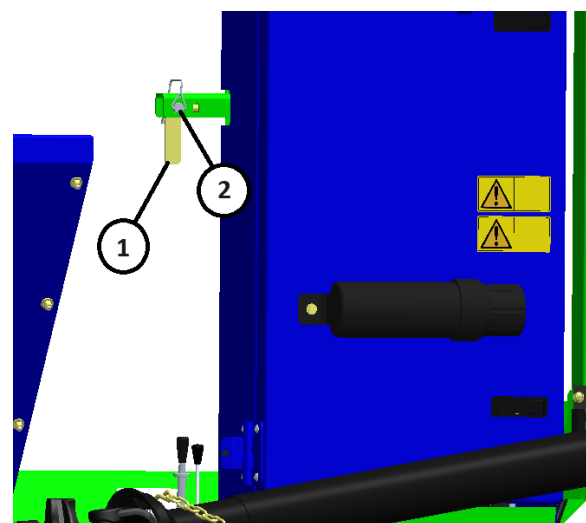

Figure 165. Tensioner Lockout
Key 1 – Handle Key 2 – Lock Pin

13 THEORY OF OPERATION

Hydraulic System

The hydraulic system is self-contained and open-center.

The PTO drives a pump drive through the gearbox. The pump pressurizes the control manifold.

System pressure is protected by a relief valve built in the control manifold.

The brake system is independent of the hydraulic system and is powered by a hand pump.

SPECIFICATIONS:

System Relief Pressure:
3,000 psi (20,685 kPa)

Brake Accumulator Pressure:
1,250 psi at 70 deg F
8,620 kPa at 21 deg C

The forage distributor motor is in series with the conveyor circuit. This is to protect the system from overload.

If the forage distributor slows or stops, the conveyor will also slow and stop.

In this event, stop the conveyor and allow the hopper to empty. Then start and stop the forage distributor to release any lodged material. Allow the hopper to clean out before continuing.

See Figures 166 and 167 for manifold functional schematics.

The functional hydraulic schematic for the machine is found on the following page in Figure 168.

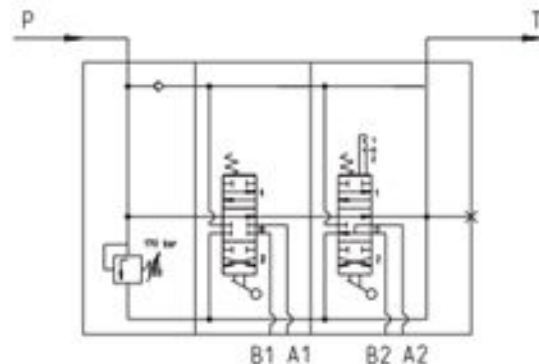

Fig. 166. 2-Bank Manifold Functional Schematic

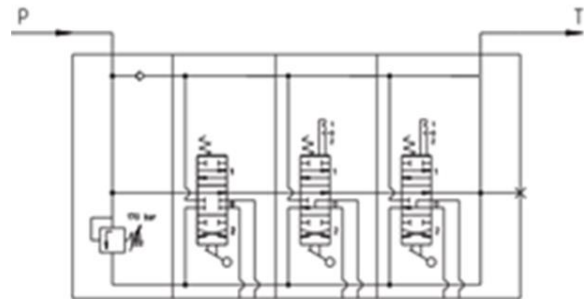

Figure 167. 3-Bank Manifold Functional Schematic

THIS PAGE INTENTIONALLY LEFT BLANK



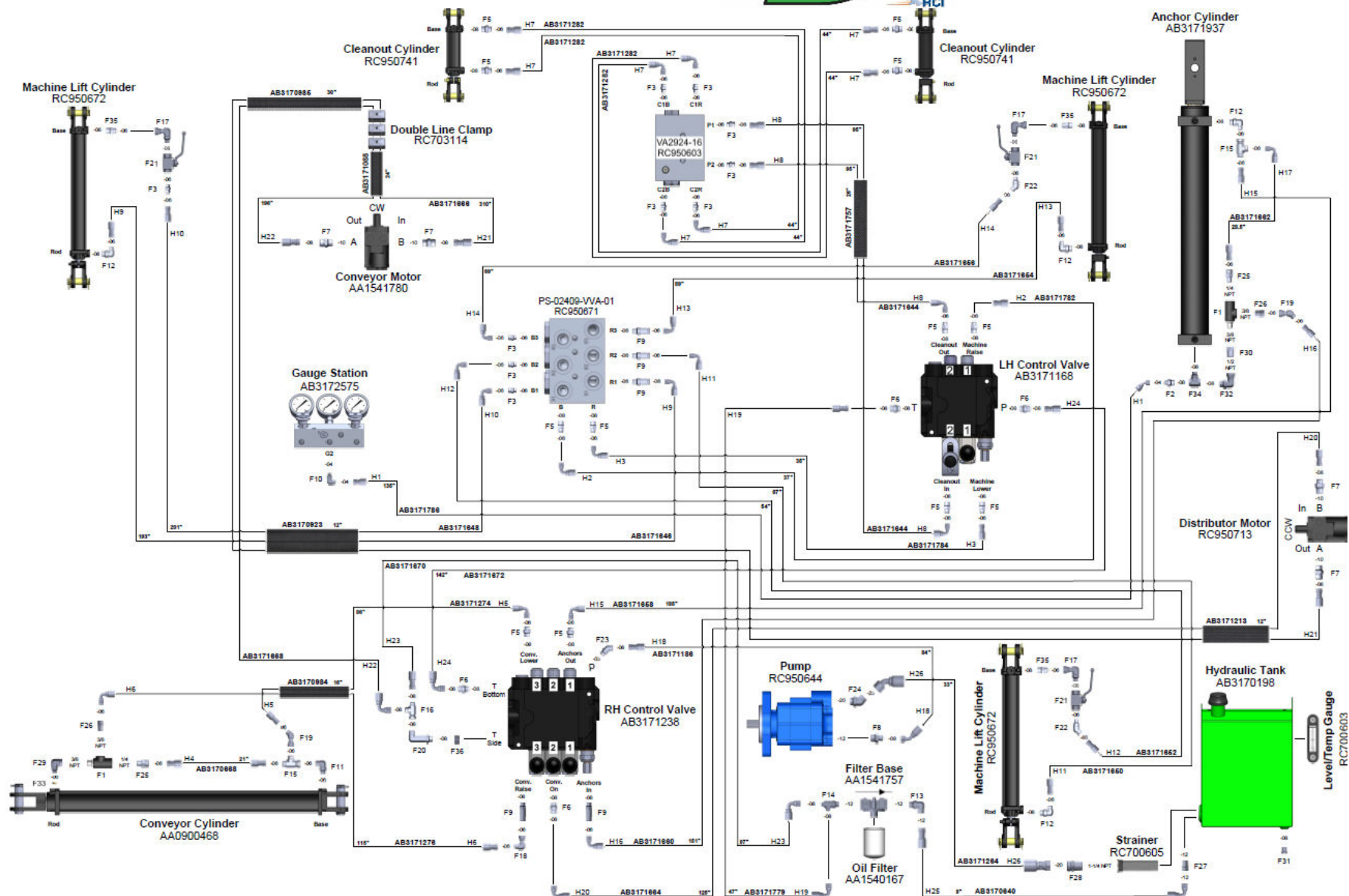

Figure 168. T8088 Hydraulic Functional Schematic

Download PDF version of manual from website to enlarge schematic for ease of component identification.

Electrical System

The T8088 may have an electrical harness for the inoculant system and a separate harness for transport lighting.

For the inoculant system, refer to the manual provided with the system.

For the transport lighting harness, the following is a description of wiring functions.

<u>Wire Color</u>	<u>FX Color</u>	<u>Function</u>
WHT	Ground	Ground
YEL	Br. Amber	LH Turn + FL
RED	Br. Red	Stop
GRN	Br. Amber	RH Turn + FL
BRN	Dim Red	Tail Lamps

14 Troubleshooting

Symptom	Cause	Solution
Rotor stops rotating. PTO shaft continues to turn.	Shear bolt on PTO shaft broken.	Replace shear bolt.
		Check and remove obstruction from hopper.
		Check for further damage.
Conveyor apron slows down or stops.	Forage distributor is overloaded.	Check that conveyor is centered on hopper.
	Conveyor is not centered on hopper.	Center conveyor on hopper.
	Build-up of product around lower apron shaft.	Open cleanout door and remove product from shaft.
	Hydraulic drive motor worn or seals leaking	Repair or replace hydraulic drive motor.
	Conveyor apron out of adjustment.	Adjust apron as required.
Brakes fail to hold wheels.	Brake pads worn.	Replace brake pads.
	Hand pump low on hydraulic jack oil.	Refill hand pump with hydraulic jack oil.
	Brake pad contact area on drum rotor rusty or corroded.	Clean rust or corrosion from drum rotor area.
	Air in brake lines.	Bleed air from system.
Conveyor fails to move down to operating position.	Dirt build-up on conveyor slides.	Clean and re-apply grease to slides.
Ag-Bag damage while Ag-Bagging.	Bag pan not properly set.	Check clearance to tunnel.
		Check folds of bag in bag pan.
	Sharp objects on tunnel.	File or remove sharp corners or objects.
	Tunnel extension lifting loop stuck in the up position.	Place tunnel extension loop in lowered position (flat against extension).
Multiple folds of Ag-Bag are sliding off tunnel.	Bungee cord does not have proper tension.	Tie knots in the bungee cords until proper tension is obtained.
	Tunnel bungee cord not properly installed.	Check bungee installation. Ensure bungee is still hooked at both ends and that all tie strings are still in place.
Brake pressure will not increase while operating hand pump.	Too much oil in hand pump.	Loosen fill plug and operate hand pump. If this corrects symptom, drain some oil from hand pump.
	Hand pump low on hydraulic jack oil.	Refill with hydraulic jack oil.

15 Storage

Before placing the Ag-Bagger into storage, prepare the unit properly.

1. Remove any product or acidic juices which will cause corrosion.
2. Open the cleanout door at the lower end of the conveyor and thoroughly clean out any product. Close the cleanout door when complete.
3. Clean out the inoculant applicator (if so equipped). Drain all liquid from unit.
4. Thoroughly wash and clean the entire Ag-Bagger.
5. After washing and prior to placing the Ag-Bagger into storage, grease and lubricate all moving parts on the Ag-Bagger. Use only oils and lubricants recommended in this manual.
6. With the Ag-Bagger running at low idle, grease both rotor bearings 20 pumps each to purge the bearings of old grease and any acidic juices that might still be present in or around the bearing.
7. Remove the rotor chain guard and remove the rotor chain from the sprockets. Soak the rotor chain in diesel fuel to clean the entire chain. When the chain is clean, soak the entire chain in oil to lubricate all the rollers.
8. Check the sprockets on the Ag-Bagger for any signs of wear. Repair or replace as needed.
9. Install the rotor chain on the sprockets. Install the rotor chain guard on the Ag-Bagger.
10. Drain the gearbox and refill with new oil. Use only oil recommended in this manual.
11. Check for wear on the rotor tooth tine caps. Replace if worn down or sharp. Also replace if there is more than 1/8" (3mm) spacing between the rotor tine caps and the stripper bar.
12. Remove all bungee cords from the Ag-Bagger and store them in the storage compartment. Use a ratchet strap or other device to hold the bag pan up during storage.
13. Release all pressure from the drum brake system. Place the pump handle in the lowered position and close the needle valves.
14. Apply a light coating of oil to the cables to prevent rusting during storage.
15. Store the Ag-Bagger inside to keep out of the weather during storage.

16 SET-UP AND ASSEMBLY

This product is shipped in a narrow configuration and requires minimal setup for field use. Once set-up is complete, review all adjustments in the *Adjustments* section of this manual and adjust as needed.

Inspect the Unit for Damage

When the unit arrives on the truck, it is important to inspect it fully for damage from transport. Any damage must be recorded, photographed, and reported to the trucking company and to Ag-Bag prior to removal from the truck.

Remove Unit from Truck

The Ag-Bagger is loaded to the truck at the factory with a large forklift.

The unit can be removed from the delivery truck in two different ways. The simplest method is to tow the unit off of the trailer by means of a dock ramp.

If this process is used, extreme care must be taken to ensure the bag pan does not contact any other object during removal. The bag pan should always be in the highest setting, both for transport and for use.

Another method is to use an appropriately sized forklift (18,000 lb. / 8,165 kg mast or greater) to lift the unit using the provided fork pockets.

The forks can only enter from the tunnel-side of the machine, under the bag pan. The unit can sit on the jack stands if needed.

Raise the green jack stand at the hitch end to the highest position. See Figures 169 through 171.



Figure 169. Forklift Moving



Figure 170. Truck Loading

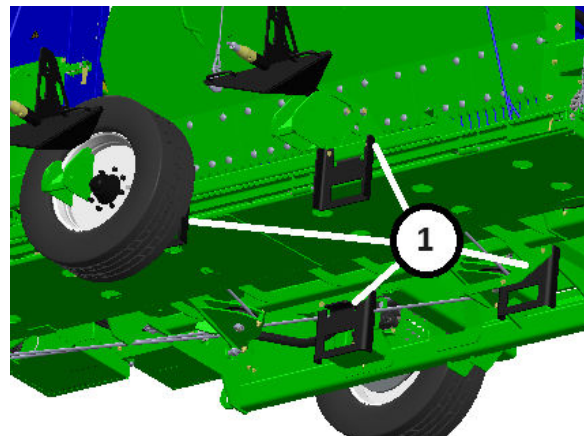

Figure 171. Bottom View from Bag Pan
Key 1 – Fork Pockets

Remove Fork Pockets

Remove the fork pockets from under the machine.

Stack the brackets and tighten the hardware in the stack of parts.

Place all components in storage compartment for the customer.

See Figure 172.

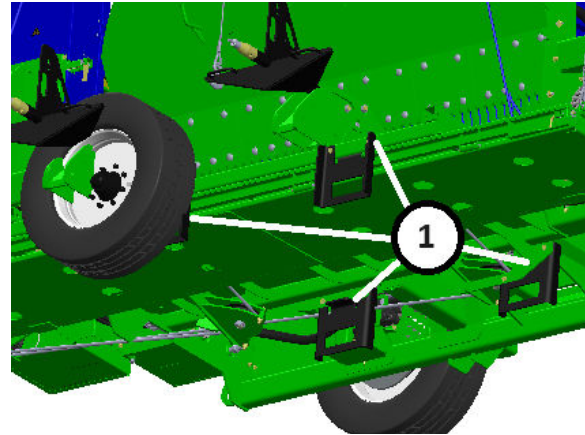

Figure 172. Bottom View from Bag Pan
Key 1 – Fork Pockets

Set Bag Pan

The Bag Pan should be in the lower holes for the highest operation.

Verify the holes and gap at the tunnel to the bag pan.

The bag pan raised position is adjustable using the stop bolts at the hinge point for the bag pan and the turn buckles at the chains on each end.

Measure the bag pan clearance to the tunnel floor. Adjust the stop bolts as needed to achieve the specification.

SPECIFICATION:

Bag Pan Clearance to Tunnel Floor
(Raised position) 3/4 in. (19mm)

See Figures 173 and 174.

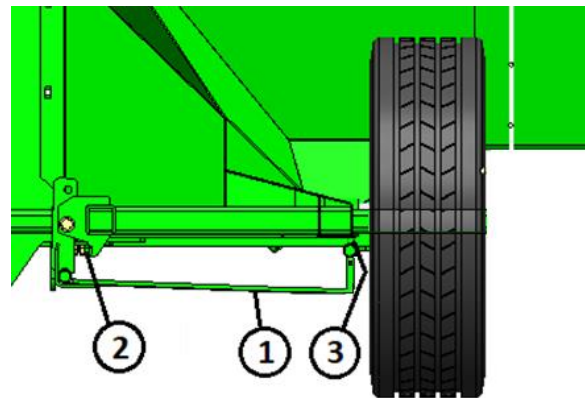

Figure 173. Bag Pan Adjust Location
Key 1 – Bag Pan Key 2 – Adjustment
Key 3 – Specified Gap

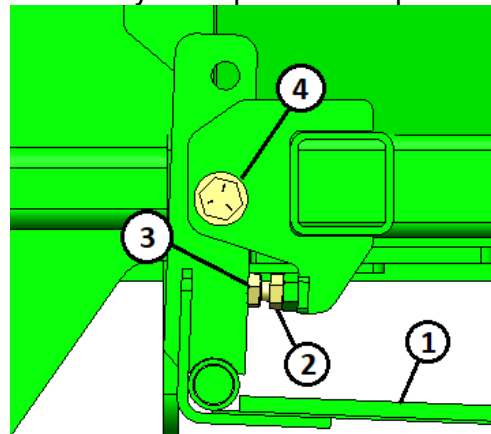

Figure 174. Bag Pan Adjustment
Key 1 – Bag Pan Key 2 – Jam Nut
Key 3 – Stop Bolt Key 4 – Hinge Point

Install the SMV Sign

The SMV sign is installed backwards or inside the storage compartment for shipping to avoid confusion for traffic during trucking to the destination.

Remove the hardware securing the SMV sign in place. Install SMV sign properly and secure with provided hardware. Tighten all hardware properly. See Figure 175.

Install Inoculant System

Install the inoculant system if customer desires. Follow instructions in the manual for the inoculant system.

Check All Fluid Levels

Check the hydraulic oil level. See *Hydraulic Oil Level Check* in the *Lubrication and Maintenance* section of this manual.

Check the gearbox and/or planetary oil level. See *Gearbox Oil* in the *Lubrication and Maintenance* section of this manual.

Check the brake system oil. See *Brake System Oil* in the *Lubrication and Maintenance* section of this manual.

Check Tire Air Pressure

Check tire air pressure. See *Tire Air Pressure* in the *Lubrication and Maintenance* section of this manual.

Check Wheel Lug Nut Torque

Check wheel lug nut torque. See *Wheel Lug Nut Torque* in the *Lubrication and Maintenance* section of this manual.

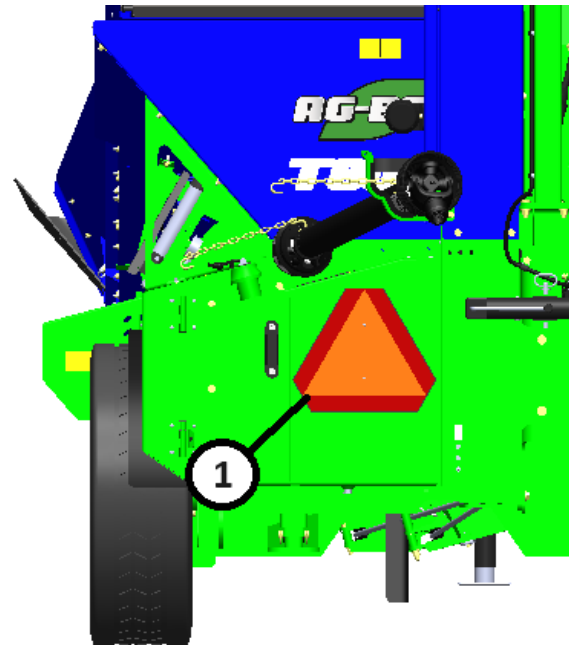

Figure 175. SMV Installation
Key 1 – SMV Sign

Grease All Functions

Use Grade 2 Lithium Complex EP Grease.

Grease the entire machine as outlined in the *Lubrication and Maintenance* section of this manual.

Oil the Chains

Oil all chains as outlined in the *Lubrication and Maintenance* section of this manual.

Pre-Operation Checklist

Complete the *Pre-Operation Checklist* in the *Operating the Unit* section of this manual.

Run The Unit

Operate the unit per the instructions in the *Operating the Unit* section of this manual to test all functions.

Make any adjustments as outlined in this manual.

Complete Documentation

Complete the *Pre-Delivery Checklist* at the end of this manual. Keep a copy for the dealership and send a copy to Ag-Bag by RCI.

Complete the *Delivery Checklist* and *Owner Registration* at the end of this manual upon final delivery. Keep a copy for the dealership and send a copy to Ag-Bag by RCI.

Ag-Bag by RCI firmly believes in continuous improvement and would appreciate any feedback available. Please contact us with any changes you would like to see in this manual.

Verify Operator Manual Returned to Unit

Upon completion of all documentation, ensure that the operator manual is placed into the holder on the machine at the storage compartment.

17 REPAIR PARTS

General Comments

The following includes information regarding parts for the T8088 Ag-Bagger.

Right- or left-hand parts are determined by sitting in the operator's seat facing forward.

The abbreviation "A.R." in the "USED" column indicates "As Required." This is because a different number of the specific component may be needed for proper assembly depending on the tolerance of the individual machine.

All parts listed are available through your local dealer.

Attention: Dealer – Contact Ag-Bag by RCI directly for all part orders for this unit.

Please include a serial number and model of the attachment when placing a parts order. The serial number plate is located near the oil filter in the service compartment.

Replacement Hardware

The use of improper hardware in any location can result in the failure of the component fastened with the hardware or related structures, and can cause personal injury, further damage to the product, or loss of property.

Replacement Parts

Replacement parts may have occasional differences to the parts being replaced. This difference is typically providing the benefit of a design change made after the release of this publication.

Repair Parts Index

Section 1 - Drive Assembly, Rotor & Forage Distributor

1.1 - Drive Assembly.....	98
1.2 - Rotor.....	102
1.3 - Forage Distributor.....	104

Section 2 - Conveyor & Hopper

2.1 - Conveyor Drive.....	106
2.2 - Conveyor Bolt-Ons.....	110
2.3 - Conveyor Lift.....	112
2.4 - Conveyor Mounting.....	114
2.5 - Hopper.....	116

Section 3 - Tunnel Cleanout

3.1 - Tunnel Cleanout.....	118
----------------------------	-----

Section 4 - Tunnels, Tunnel Mounting, Bag Boom & Cradle

4.1 - 10' Tunnel.....	120
4.2 - 12' Tunnel.....	120
4.3 - Tunnel Mounting.....	124
4.4 - Bag Boom.....	126
4.5 - Cradle.....	128

Section 5 - Anchor System

5.1 - Anchors.....	130
5.2 - Anchor Cylinder.....	132
5.3 - Anchor Take-up.....	134
5.4 - Anchor Cylinder & Take-up Enclosure.....	136

Section 6 - Bag Pan

6.1 - Bag Pan.....	138
--------------------	-----

Section 7 - Shields & Storage Compartment

7.1 - Shields.....	140
7.2 - Storage Compartment.....	144

Section 8 - Transportation Components, Brakes, Machine Lift & Decals

8.1 - Transport.....	146
8.2 - Brake System - S/N up to 401098.....	148
8.3 - Brake System - S/N 401099 – X.....	152
8.4 - Hitch.....	156
8.5 - Light Bar.....	158
8.6 - Hydraulic Machine Lift.....	160
8.7 - Machine Decals.....	162
8.8 - Conveyor Decals.....	164

Section 9 - Control Valve Fittings & Hydraulic Tank

9.1 - RH Control Valve Fittings.....	166
9.2 - LH Control Valve Fittings.....	168
9.3 - Hydraulic Tank.....	170

Section 10 - Component Breakdowns

10.1 - Planetary Gearbox.....	172
10.2 - 1000 PTO.....	174
10.3 - RH Control Valve.....	176
10.4 - LH Control Valve.....	178
10.5 - Hand Pump.....	180
10.6 - Brake Caliper.....	182
10.7 - Spindle.....	184
10.8 - 2-Way Flow Divider.....	186
10.9 - 3-Way Flow Divider.....	188
10.10 - Gauge Station Assembly.....	190

Section 11 - Options

11.1 - Gandy Option.....	192
11.2 - Gandy Dry Inoculator.....	194
11.3 - Miscellaneous Items.....	196

Section 12 – Grease & Hydraulic Schematics

12.1 - Grease Schematic.....	198
12.2 - Hydraulic Schematic - S/N up to 401098.....	200
12.3 - Hydraulic Schematic - S/N 401099 – X.....	206

1.1 – Drive Assembly

Key	Part Number	Description	Qty	Comments
1	AB3171358	Frame, T8088 Main	1	
2	AB3170939	Gearbox, Planetary	1	See breakdown on Parts Page 10.1
3	AB3171214	Oil, Mobil SHC Gear 220 - 1.75 gal.	1	Oil for Gearbox
4	AB3171098	PTO, 1000 RPM	1	See breakdown on Parts Page 10.2
5	AB3170174	Support, Gearbox	1	
6	AB3171503	Shaft, T8088 Intermediate	1	
7	RC950644	Pump, 2100 Series Gear	1	
7a	RC950665	Kit, Seal	1	
8	AB3171699	Brace, Bearing Mount	1	
9	AA0900372	Bearing, 3-7/16" - 4 Bolt Flange Spherical Roller	2	
10	AB3170938	Chain, 120-2 XDO x 71 Pitches + Split Cotter Connector Link	1	
10a	AA1520068	Link, 120-2 XDO Split Cotter Connector	1	
11	AB3170994	Arm, Chain Tensioner	1	
12	AA6002007	Tensioner, Rtr Chn Cable Mod	1	
13	AB3170500	Spacer, YZ Sprocket	1	
14	AB3170512	Spacer, YZ Shaft	1	
15	AB3170935	Sprocket, Planetary Coupler	1	
16	AB3170934	Sprocket, Planetary Shaft Coupler	1	
17	AB3170936	Sprocket, 120-2A12 70X64 Spline	1	
18	AA0900377	Sprocket, 120-2B48 3-7/16B 7/8K	1	
19	AB3170937	Chain, 120-2 XDO x 15 Pitches + Split Cotter Connector Link	1	
19a	AA1520068	Link, 120-2 XDO Split Cotter Connector	1	
20	AA1500483	Spring, #661 Extension	1	
21	AB3170501	Rod, Chain Tensioner	1	
22	AB3170315	Rest, PTO	1	
23	AA0900559	Lock, PTO Cradle	1	
24	AB3170685	Trim, 14" C.L. PTO Holder Edge	1	
25	RC950571	Chain, PTO Shield Safety	2	
26	AB3171023	Washer, Planetary Shaft	1	
27	RC902780	Carabiner, 3/8 x 3-3/16 CZ	1	
28	AB3170624	Wrap, 36" C.L. -06 Ballistic	1	
29	RC950638	Chain, 1/4 CZ Grade 43 x 34 Links	1	
30	AB3170485	Support, Conveyor	1	
31	AB3171773	Shim, 060 Bearing	AR	
32	AB3171774	Shim, 036 Bearing	AR	
33	AB3171777	Plate, Bearing Stop	1	

1.1 – Drive Assembly - Continued

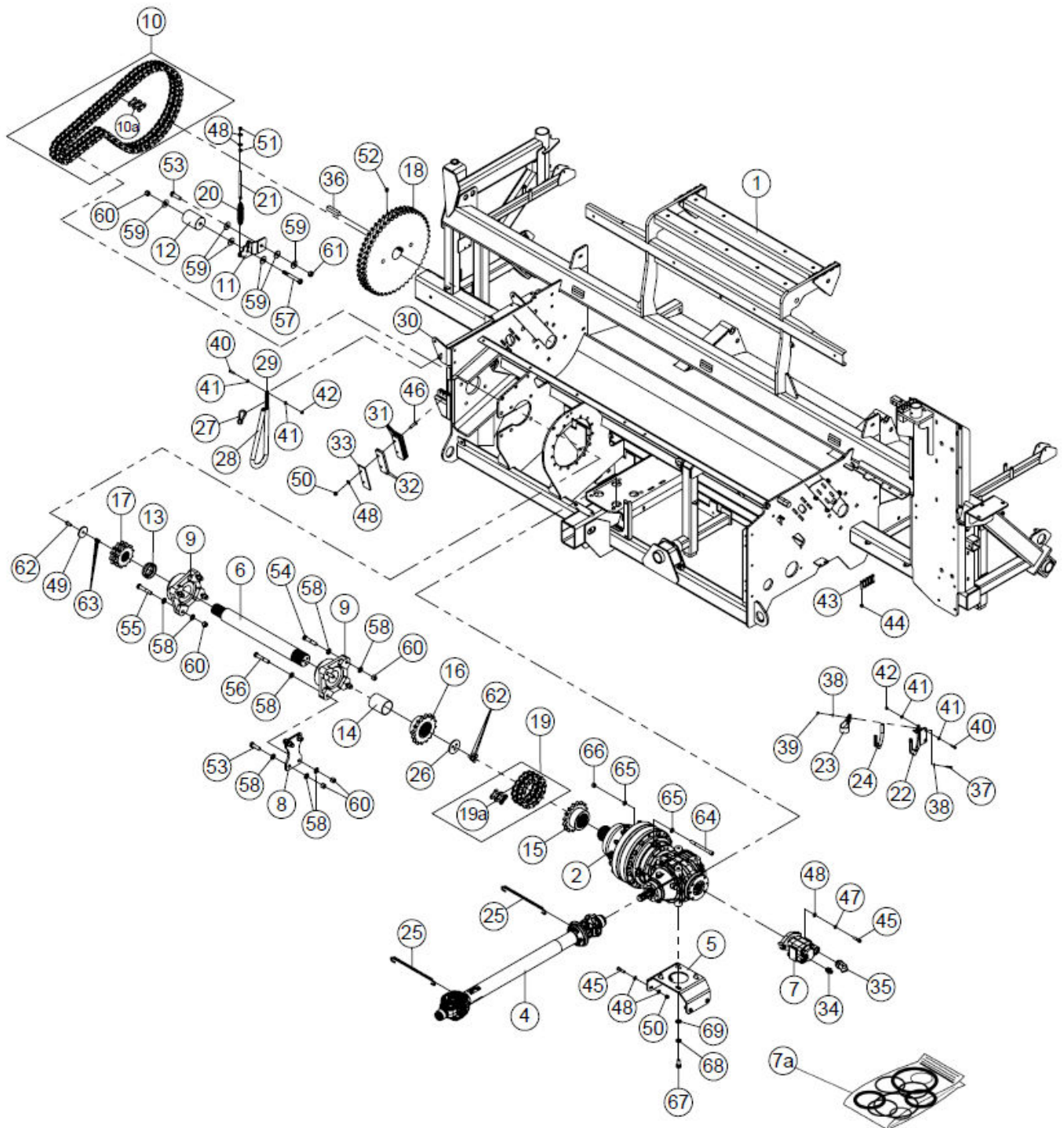

1.1 – Drive Assembly – Continued

Key	Part Number	Description	Qty	Comments
34	RC700085	Adapter, -08 MORFS -12 MORB Straight	1	
35	RC700898	Elbow, -20 MORFS -20 MORB 45°	1	
36	AA907688	Key, 7/8 x 7/8 x 4.00 1018	1	
37	RC900064	Bolt, 5/16-18 x 1-1/4 Gr5 YZ Hex	2	
38	RC902162	Washer, 5/16 SAE YZ Hard Flat	4	
39	RC900579	Nut, 5/16-18 YZ Nylock	2	
40	RC900091	Bolt, 3/8-16 x 1-1/4 Gr 5 YZ Hex	3	
41	RC900677	Washer, 3/8 SAE YZ Hard Flat	6	
42	RC900583	Nut, 3/8-16 YZ Nylock	3	
43	RC901476	Bolt, 7/16-14 x 2 Gr 5 CZ Hex	5	Spare PTO Hardware
44	RC901581	Nut, 7/16-14 CZ Top Lock	5	Spare PTO Hardware
45	RC900137	Bolt, 1/2-13 x 2 Gr 5 YZ Hex	6	
46	RC900431	Bolt, 1/2-13 x 2 Gr 5 CZ Carriage	2	
47	RC900731	Washer, 1/2 YZ Lock	2	
48	RC900691	Washer, 1/2 SAE YZ Hard Flat	14	
49	RC902776	Washer, 1/2 CZ Extra-Thick Fender (3 O.D.)	1	
50	RC900588	Nut, 1/2-13 YZ Nylock	6	
51	RC900529	Nut, 1/2-13 YZ Hex	2	
52	RC902719	Screw, 3/4-10 x 3/4 Socket Cup Point Set	2	
53	RC900204	Bolt, 3/4-10 x 2-1/2 Gr 5 YZ Hex	3	
54	RC900210	Bolt, 3/4-10 x 3-3/4 Gr 5 YZ Hex	2	
55	RC900212	Bolt, 3/4-10 x 4 Gr 5 YZ Hex	4	
56	RC902863	Bolt, 3/4-10 x 4-1/4 Gr 5 YZ Hex	2	
57	RC902733	Bolt, 3/4-10 x 5-3/4 Gr 8 YZ Hex	1	
58	RC902416	Washer, 3/4 SAE YZ Hard Flat	20	
59	RC902587	Washer, 3/4 USS YZ Hard Flat	6	
60	RC900597	Nut, 3/4-10 YZ Nylock	11	
61	RC902717	Nut, 3/4-10 Gr 8 YZ Center Lock	1	
62	RC901211	Bolt, M14-2.0 x 30mm Gr 10.9 YZ Hex	4	
63	RC902762	Washer, 14mm x 1mm SS Shim	AR	
64	RC902807	Screw, M16-2.0 x 180mm BO Socket Head Cap	15	
65	RC901945	Washer, M16 YZ Flat	30	
66	RC901789	Nut, M16-2.0 Gr 10 CZ Nylock	15	
67	RC902775	Bolt, M20-2.5 x 40mm Gr 10.9 YZ Hex	4	
68	RC901299	Washer, M20 CZ Lock	4	
69	RC901356	Washer, M20 YZ Flat	4	

1.2 – Rotor

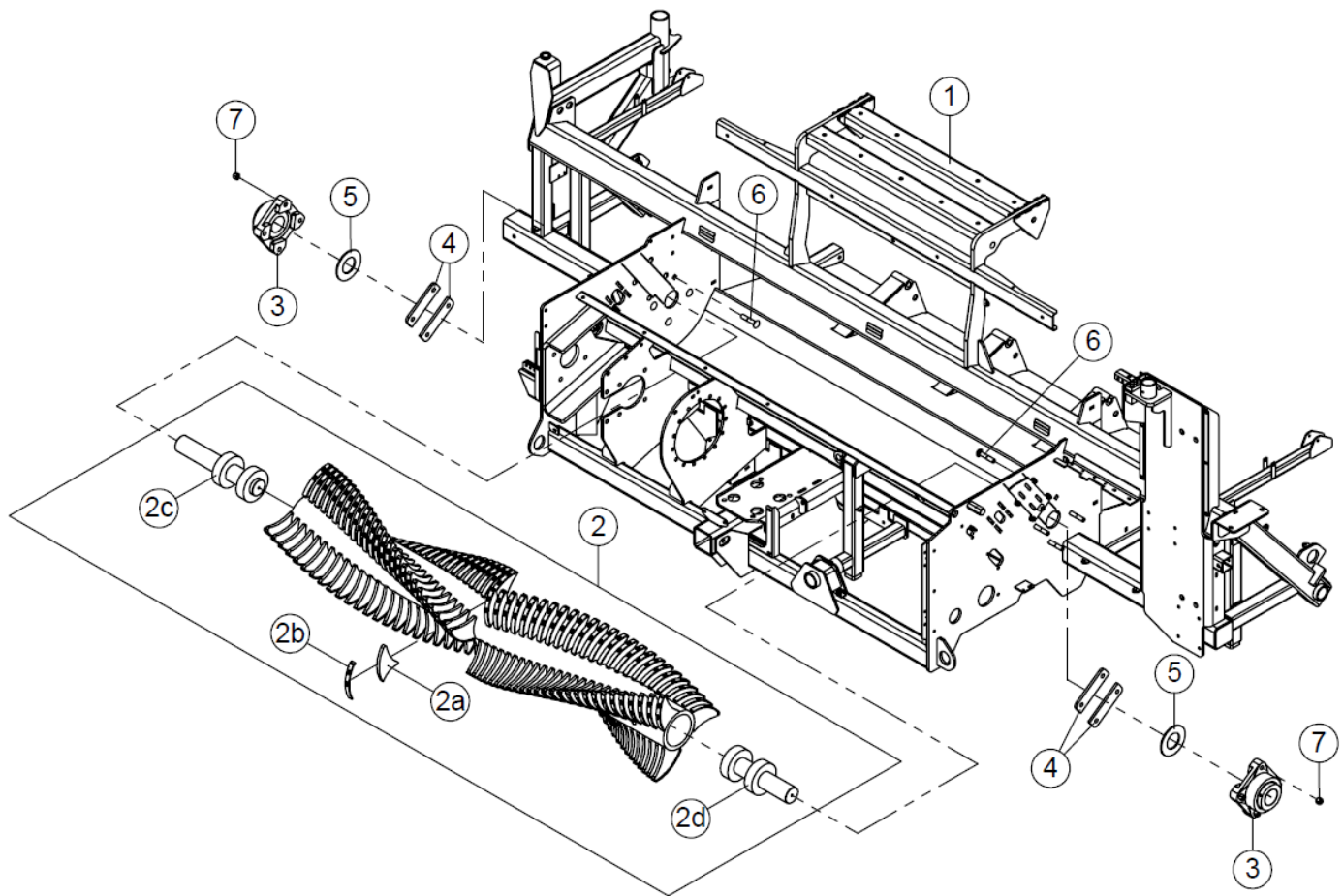

1.2 – Rotor

Key	Part Number	Description	Qty	Comments
1	AB3171358	Frame, T8088 Main	1	
2	AB3171021	Rotor, 104"	1	
2a	AB3170904	Tooth, Rotor	156	
2b	AA1020001	Cap, 1 X 3/16 X 8-13/16 Tine	156	
2c	AB3171701	Shaft, T8088 Rotor Drive	1	
2d	AB3170306	Shaft, T8088 Rotor Idle	1	
3	AA0900372	Bearing, 3-7/16" - 4 Bolt Flange Roller	2	
4	AB3170280	Spacer, Rotor Bearing	4	
5	AB3170999	Ring, Rotor Shaft	2	
6	RC902771	Bolt, 3/4 x 4 Gr 5 CZ Carriage	8	
7	RC900597	Nut, 3/4-10 YZ Nylock	8	

1.3 – Forage Distributor

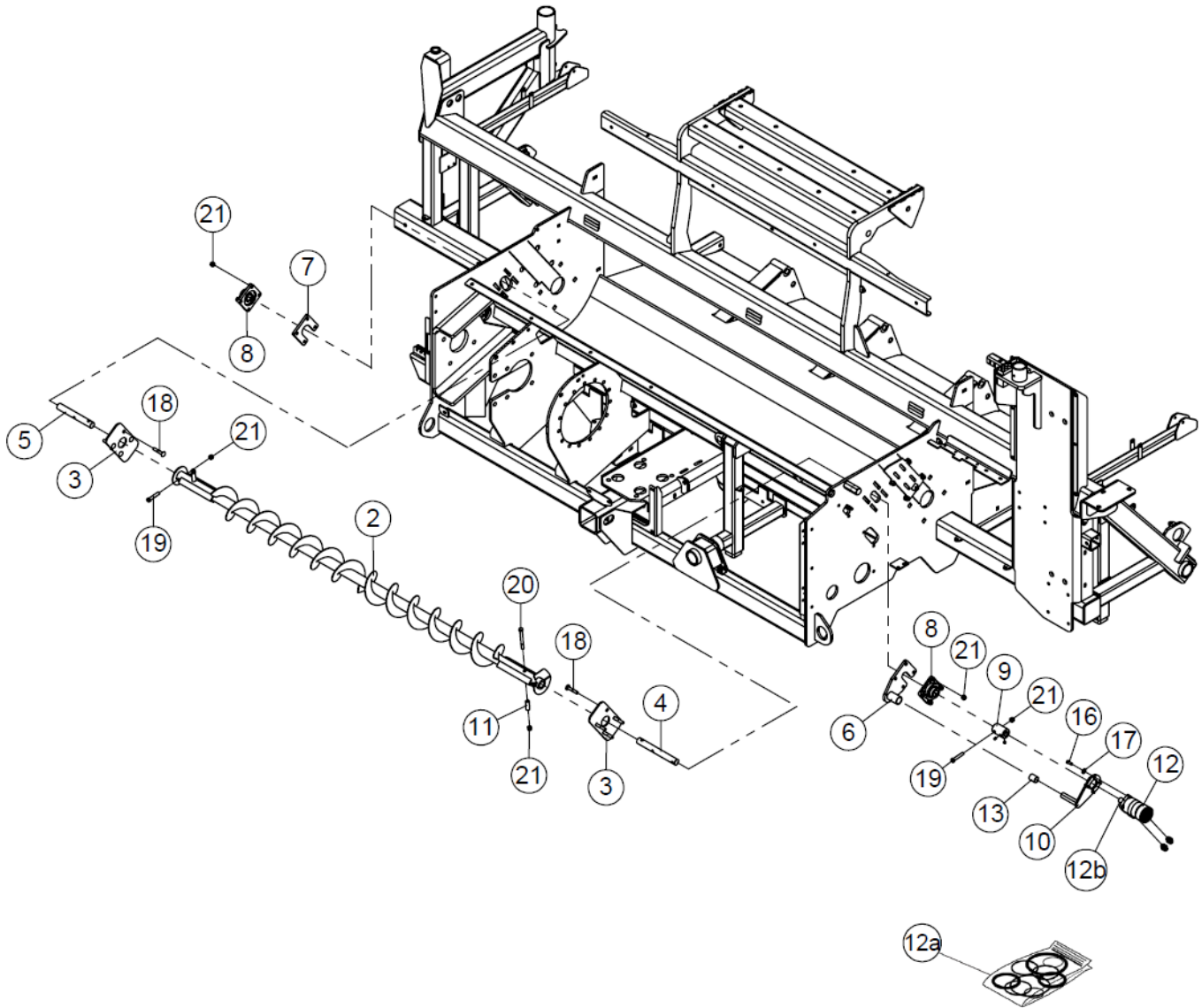

1.3 – Forage Distributor

Key	Part Number	Description	Qty	Comments
1	AB3171358	Frame, T8088 Main	1	
2	AB3171682	Distributor, T8088 Forage	1	
3	AB3170521	Plate, Adjuster Filler	2	
4	AB3171707	Shaft, Distributor Drive	1	
5	AA3160365	Shaft, Auger	1	
6	AB3170519	Spacer, Motor Bearing	1	
7	AB3170515	Plate, Bearing Spacer	1	
8	RC950580	Bearing, 1-1/4" Bore w/ 4-Bolt Flange	2	
9	AB3171709	Coupler, Distributor Motor	1	
10	AA6008011	Mount, Motor	1	
11	AB3171705	Spacer, Distributor	2	
12	RC950713	Motor, Hydraulic	1	
12a	RC950721	Kit, High Pressure Seal	1	
12b	AA0901800	Key, Conveyor Motor	1	
13	AA1501477	Tubing, 1-1/4" OD x 1" ID x 1-1/2" Black Vinyl	1	
14	RC700084	Adapter, -08 MORFS -10 MORB Straight	2	
15	RC902255	Screw, 3/8-16 x 1/2 Socket Knurled Cup Set	2	
16	RC900088	Bolt, 3/8-16 x 1 Gr 5 YZ Hex	4	
17	RC902699	Washer, 3/8 USS YZ Hard Flat	4	
18	RC901674	Bolt, 1/2-13 x 2-3/4 Gr 5 CZ Carriage	8	
19	RC900141	Bolt, 1/2-13 x 2-3/4 Gr 5 YZ Hex	3	
20	RC902865	Bolt, 1/2-13 x 4-3/4 Gr 5 YZ Hex	2	
21	RC900588	Nut, 1/2-13 YZ Nylock	13	

2.1 – Conveyor Drive

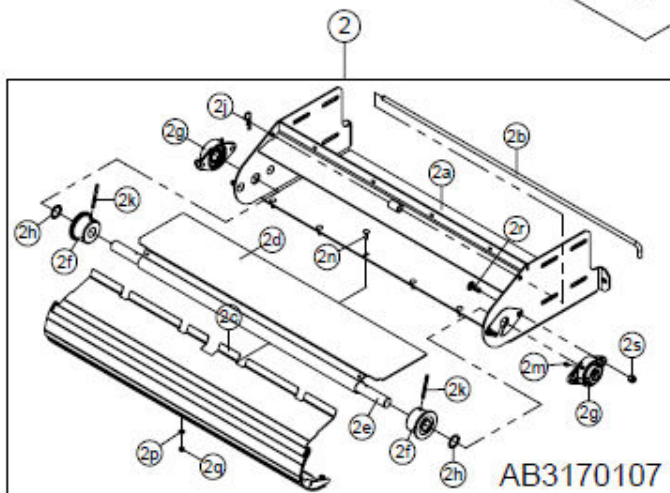
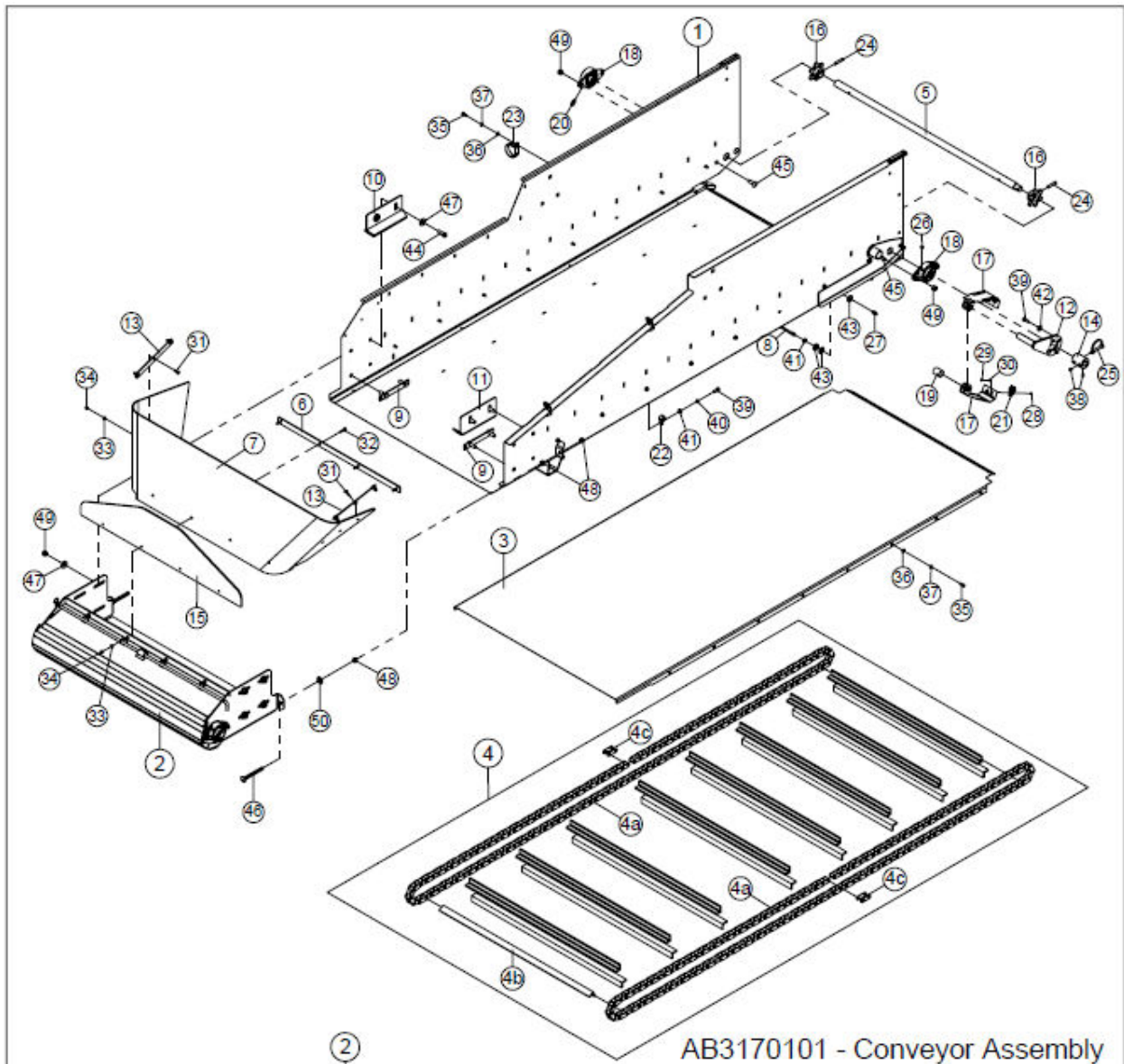

2.1 – Conveyor Drive

Key	Part Number	Description	Qty	Comments
1	AB3170104	Frame, Wide Single Conveyor	1	
2	AB3170107	Assembly, Wide Single Conveyor End	1	
2a	AB3170106	End, Wide Single Conveyor	1	
2b	AB3170117	Pin, Wide YZ Latch	1	
2c	AB3170112	Door, Wide Single Conveyor Clean Out	1	
2d	AB3170976	Transition, Conveyor	1	
2e	AB3170119	Shaft, 1-1/4 x 46-3/4 YZ Idler	1	
2f	AA0900987	Roller, 1.250 Bore Conveyor	2	
2g	AB3171279	Bearing, 1-1/4" Bore 2-Bolt Flange Eccentric	2	
2h	RC902818	Shim, 1-1/4 x .048 SS Shim	2	
2j	RC900895	Hairpin, .148 x 2-11/16 CZ	1	
2k	RC900869	Pin, 5/16 x 3 Plain Roll	1	
2m	RC901873	Zerk, 1/8 NPT Straight Grease	2	
2n	RC901668	Bolt, 5/16-18 x 1 Gr 5 CZ Carriage	6	
2p	RC902162	Washer, 5/16 SAE YZ Hard Flat	6	
2q	RC900579	Nut, 5/16-18 YZ Nylock	6	
2r	RC902769	Bolt, 1/2-13 x 1-1/2 Gr 5 CZ Carriage	4	
2s	RC900588	Nut, 1/2-13 YZ Nylock	4	
3	AB3170132	Weldment, Wide Conveyor Pan	1	
4	AB3170127	Chain, Wide Single Conveyor	1	
4a	AA3160454	Chain, Single Conveyor Side	2	
4b	AB3170128	Angle, Wide Conveyor Chain	17	
4c	AA900703	Link, CA550 Chain Connecting	2	
5	AB3170130	Shaft, 1-1/4 YZ Wide Conveyor Drive	1	
6	AB3170143	Strip, Wide Conveyor Skirting Center	1	
7	AB3170144	Skirt, Wide Conveyor	1	
8	AB3170410	Hose, 1/8" x 52" Grease	1	
9	AA6008104	Bracket, Conveyor Nose Cone	2	
10	AA6008072	Guide, Conveyor Chain - Top LH	1	
11	AA6008073	Guide, Conveyor Chain - Top RH	1	
12	AA6008011	Mount, Motor	1	
13	AA6008021	Strip, Conveyor Skirting Side	2	
14	AB3170987	Coupler, Motor	1	
15	AB3170977	Brace, UHMW Conveyor Skirt	1	
16	AA1520773	Sprocket, 6 Tooth 1-1/4 Bore	2	
17	AB3171286	Shield, Motor Coupler	2	
18	AB3171279	Bearing, 1-1/4" Bore 2-Bolt Flange Eccentric	2	

2.1 – Conveyor Drive - Continued

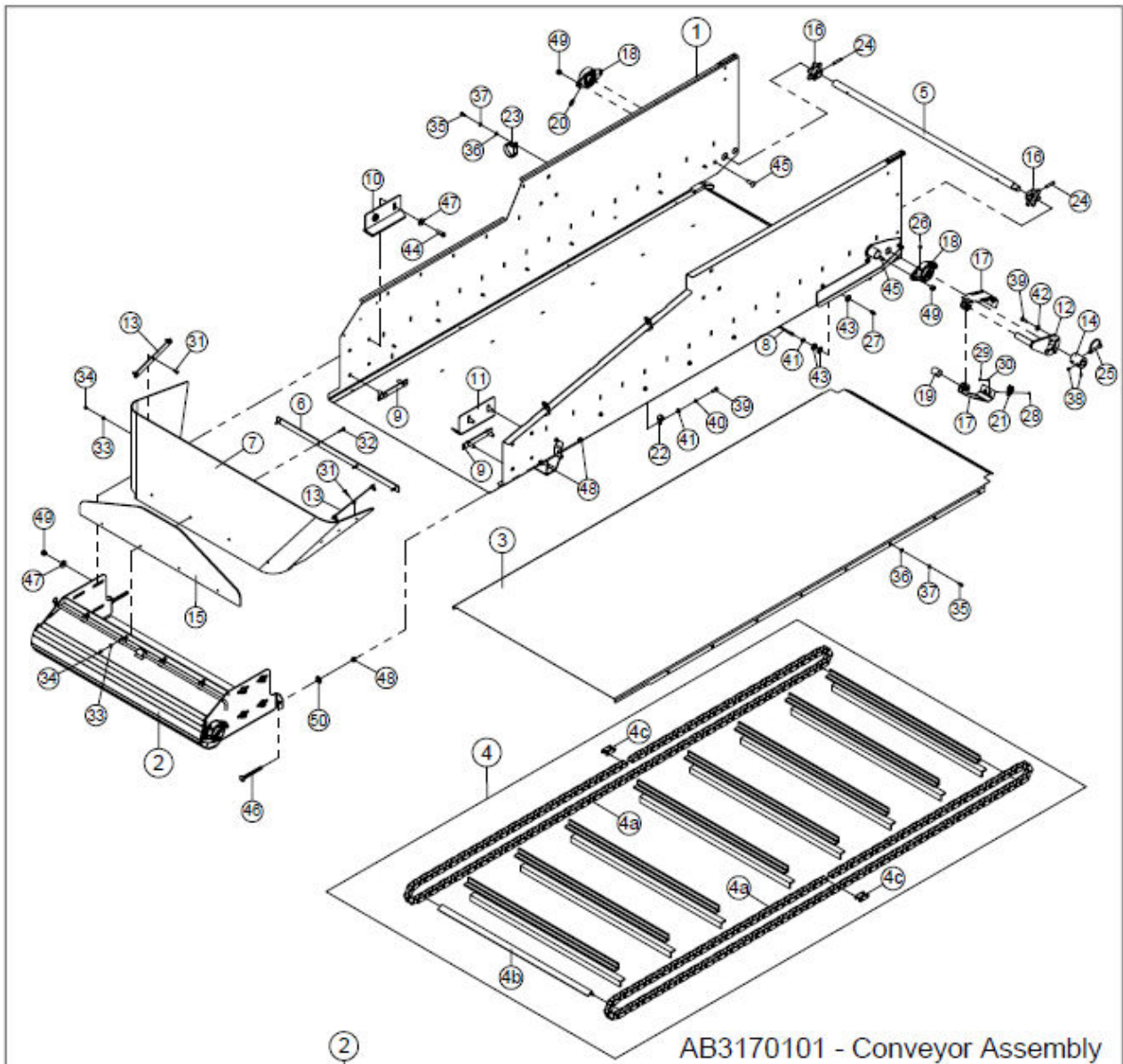

AB3170101 - Conveyor Assembly

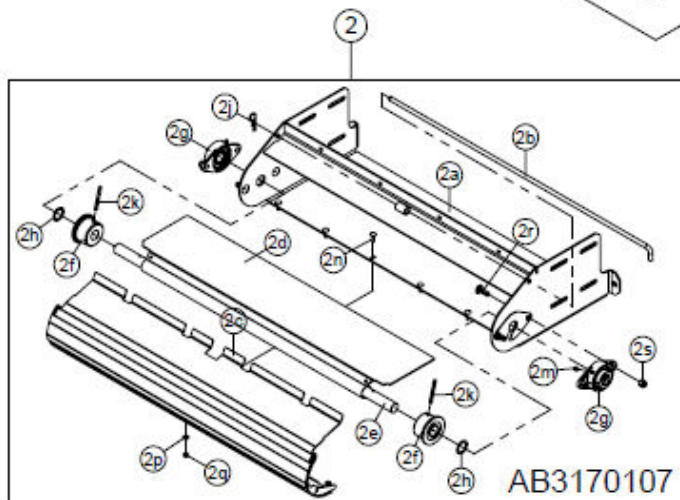

AB3170107

2.1 – Conveyor Drive - Continued

Key	Part Number	Description	Qty	Comments
19	AA1501477	Tubing, 1-1/4" OD x 1" ID x 1-1/2" Black Vinyl	1	
20	RC701534	Adapter, 1/8 NPT 1/8 NPSM Straight Swivel	1	
21	RC950703	Latch, Tight-Hold Draw	1	
22	RC902616	P-Clamp, 5/8 Cushion	4	
23	RC902067	P-Clamp, 2-1/2 Cushion	1	
24	RC902724	Pin, 3/8 x 2 Plain Roll	2	
25	RC902857	Pin, 3/8 x 2-1/4 YZ Locking Round Retainer	1	
26	RC901873	Zerk, 1/8 NPT Straight Grease	1	
27	RC901968	Zerk, 1/8-27 FPT Straight Grease	1	
28	RC902850	Screw, #5-40 x 3/8 CZ Ph Pan Hd	4	
29	RC902136	Nut, #5-40 CZ Nylock	4	
30	RC902272	Washer, #5 CZ SAE Flat	4	
31	RC901557	Bolt, 1/4-20 x 1 CZ Carriage	6	
32	RC902310	Bolt, 1/4-20 x 1-1/4 CZ Carriage	4	
33	RC902696	Washer, 1/4 SAE YZ Hard Flat	10	
34	RC900575	Nut, 1/4-20 YZ Nylock	10	
35	RC900084	Bolt, 5/16-18 x 3/4 Gr 5 YZ Hex	16	
36	RC902162	Washer, 5/16 SAE YZ Hard Flat	16	
37	RC900726	Washer, 5/16 YZ Lock	16	
38	RC902255	Screw, 3/8-16 x 1/2 Socket Knurled Cup Set	2	
39	RC900088	Bolt, 3/8-16 x 1 Gr 5 YZ Hex	8	
40	RC900728	Washer, 3/8 YZ Lock	4	
41	RC900677	Washer, 3/8 SAE YZ Hard Flat	5	
42	RC902699	Washer, 3/8 USS YZ Hard Flat	4	
43	RC901760	Washer, 7/16 USS YZ Hard Flat	3	
44	RC900135	Bolt, 1/2-13 x 1-1/2 Gr 5 YZ Hex	4	
45	RC902769	Bolt, 1/2-13 x 1-1/2 Gr 5 CZ Carriage	4	
46	RC902728	Bolt, 1/2-13 x 5 Gr 5 CZ FT Carriage	2	
47	RC900689	Washer, 1/2 USS YZ Hard Flat	12	
48	RC900529	Nut, 1/2-13 YZ Hex	6	
49	RC900588	Nut, 1/2-13 YZ Nylock	12	
50	RC900694	Washer, 5/8 SAE YZ Hard Flat	2	
	AB3170416	Kit, Conveyor Decal	1	Spare Part
	RC901939	Reflector, Yellow 2 x 9	1	Spare Part

2.2 – Conveyor Bolt-Ons

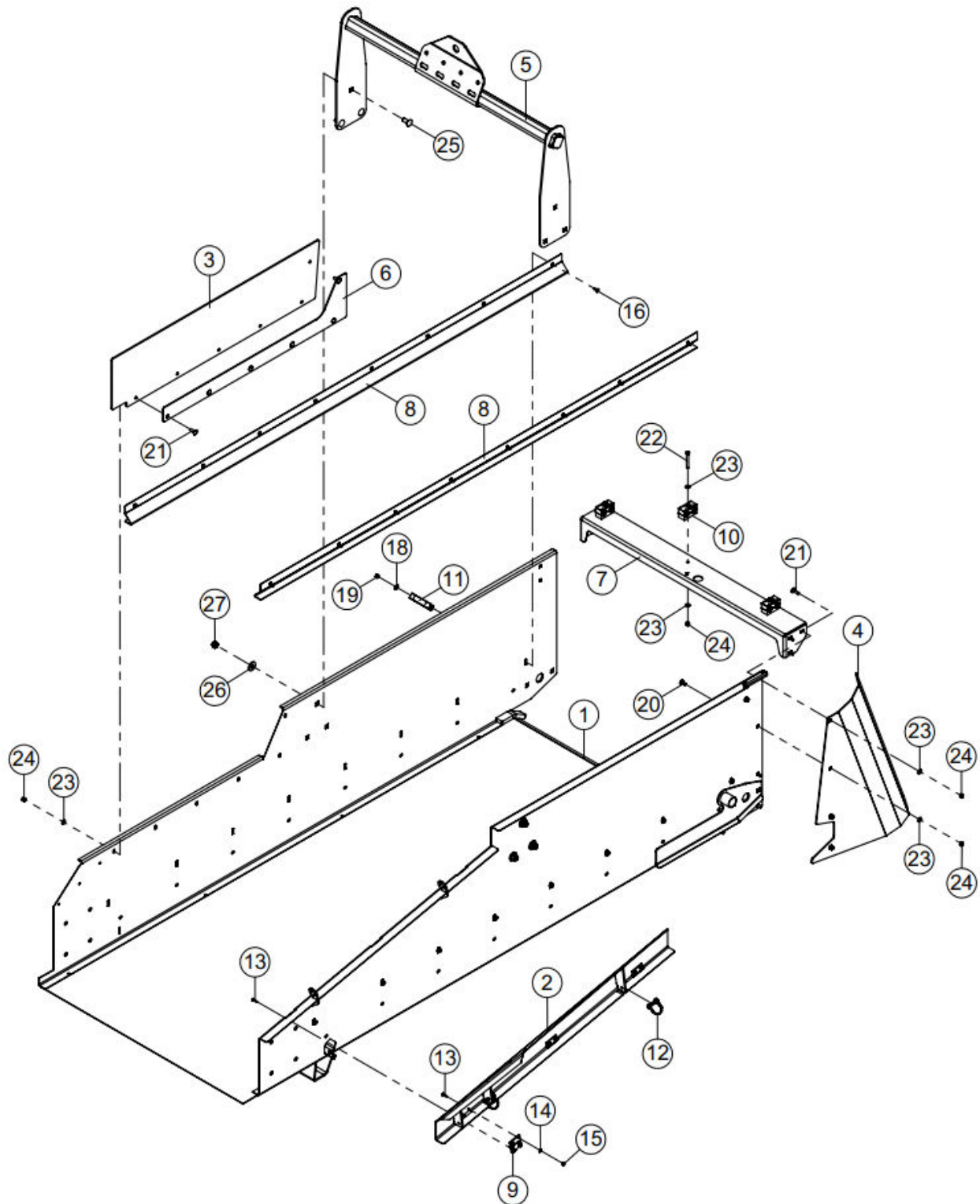

2.2 – Conveyor Bolt-Ons

Key	Part Number	Description	Qty	Comments
1	AB3170104	Frame, Wide Single Conveyor	1	
2	AB3170141	Panel, Hinged Side	1	
3	AB3170632	Skirt, 10" x 42.5" Rubber Side	1	
4	AB3170146	Deflector, Wide Conveyor	1	
5	AB3170206	Bracket, Gandy Lift	1	
6	AB3170201	Strip, Wide Conveyor Side Skirt	1	
7	AB3170916	Brace, Conveyor Side	1	
8	AB3170982	Shingle, Conveyor	2	
9	RC902148	Hinge, 2 x 2 SS Door	3	
10	RC703114	Clamp, Double Line .84" ID	3	
11	RC902067	P-Clamp, 2-1/2 Cushion	1	
12	RC902827	Pin, 3/8 x 1-1/8 CZ Locking Round Retainer	2	
13	RC901775	Screw, #10-24 x 3/4 CZ Ph Pan Hd	12	
14	RC900667	Washer, #10 SAE YZ Flat	12	
15	RC902420	Nut, #10-24 YZ Nylock	12	
16	RC902377	Bolt, 1/4-20 x 3/4 CZ Gr 5 Carriage	16	
17	RC902696	Washer, 1/4 SAE YZ Hard Flat	15	
18	RC902697	Washer, 1/4 USS YZ Hard Flat	1	
19	RC900575	Nut, 1/4-20 YZ Nylock	16	
20	RC901753	Bolt, 5/16-18 x 3/4 Gr 5 CZ Carriage	7	
21	RC901668	Bolt, 5/16-18 x 1 Gr 5 CZ Carriage	7	
22	RC900071	Bolt, 5/16-18 x 2-1/2 Gr 5 YZ Hex	3	
23	RC902162	Washer, 5/16 SAE YZ Hard Flat	20	
24	RC900579	Nut, 5/16-18 YZ Nylock	17	
25	RC900426	Bolt, 1/2-13 x 1-1/4 Gr 5 CZ Carriage	6	
26	RC900689	Washer, 1/2 USS YZ Hard Flat	6	
27	RC900588	Nut, 1/2-13 YZ Nylock	6	

2.3 – Conveyor Lift

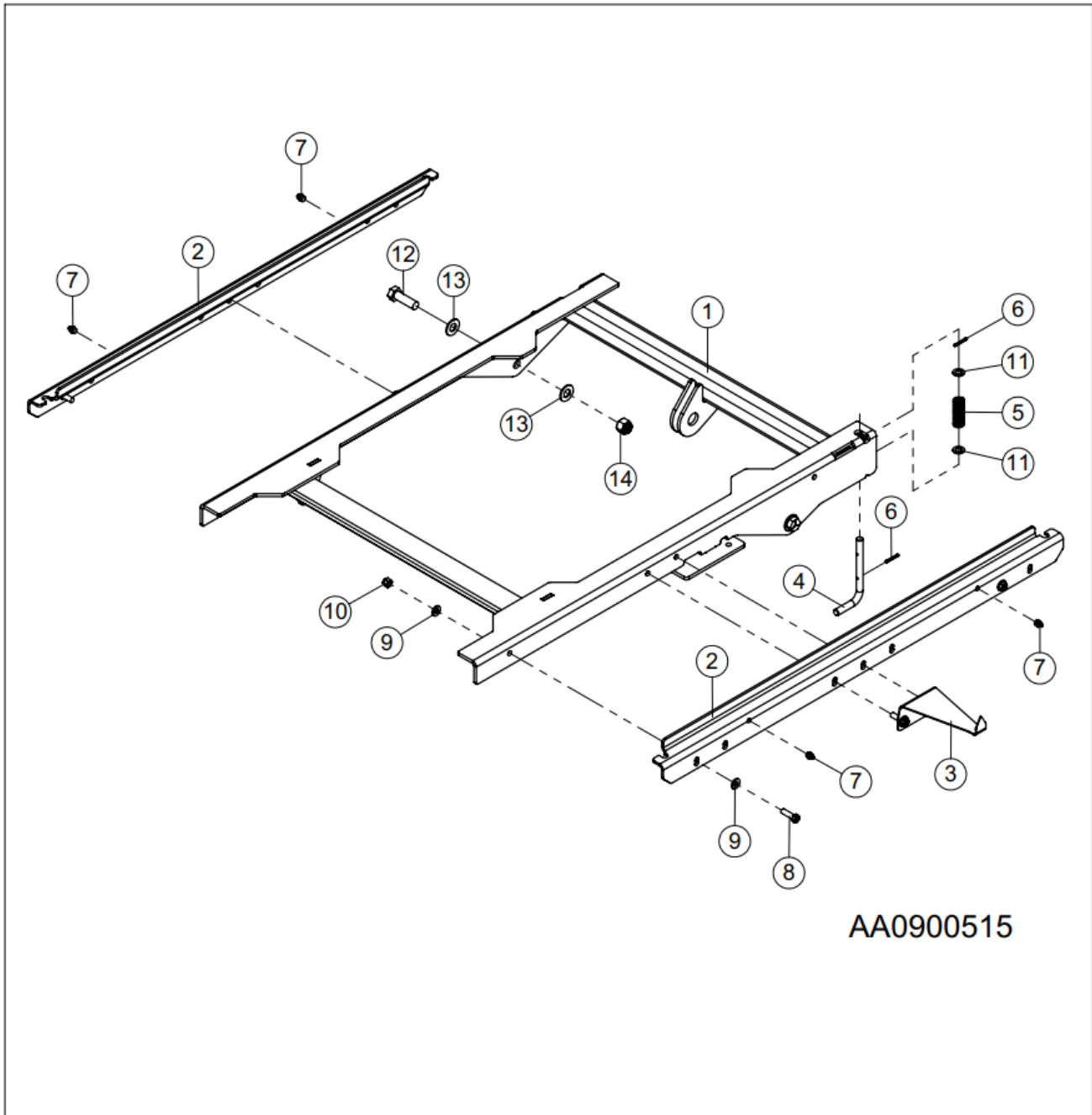

2.3 – Conveyor Lift

Key	Part Number	Description	Qty	Comments
1	AA0900441	Frame, Conveyor Slide	1	
2	AA0900484	Hold Down, Conveyor	2	
3	AB3171727	Indicator, Conveyor Position	1	
4	AA1700750	Pin, Cam Lever	1	
5	AA0717764	Spring	1	
6	RC902761	Pin, 5/32 x 1-1/4 CZ Roll	2	
7	RC901873	Zerk, 1/8 NPT Straight Grease	4	
8	RC900091	Bolt, 3/8-16 x 1-1/4 Gr 5 YZ Hex	6	
9	RC900677	Washer, 3/8 SAE YZ Hard Flat	12	
10	RC900583	Nut, 3/8-16 YZ Nylock	6	
11	RC902770	Washer, 1/2 x 14 Ga CZ Machinery Bushing	2	
12	RC900168	Bolt, 5/8 x 2 Gr 5 YZ Hex	4	
13	RC900694	Washer, 5/8 SAE YZ Hard Flat	8	
14	RC900593	Nut, 5/8-11 YZ Nylock	4	

2.4 – Conveyor Mounting

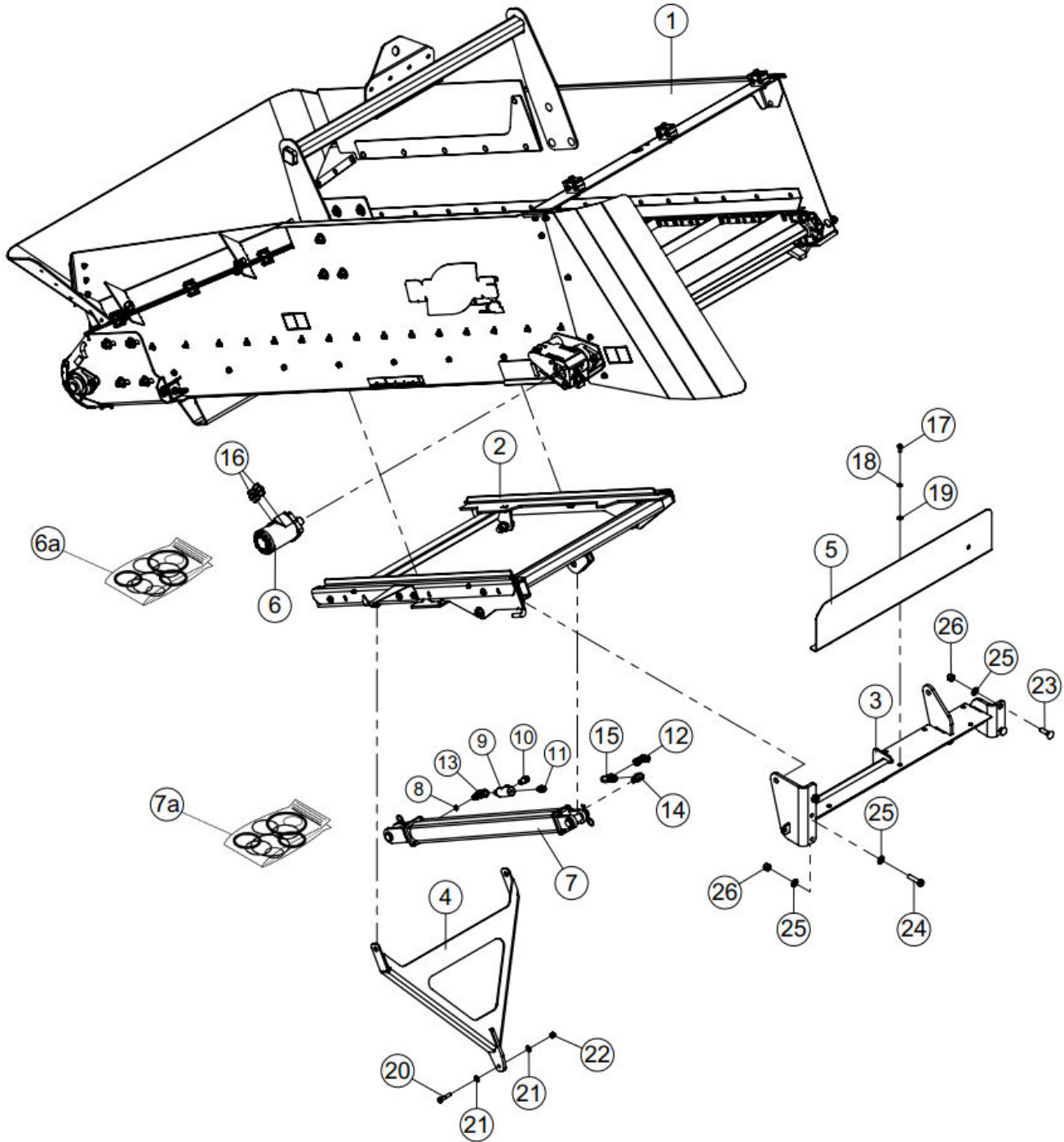

2.4 – Conveyor Mounting

Key	Part Number	Description	Qty	Comments
1	AB3170101	Assembly, Wide Single Chain Conveyor	1	
2	AA0900515	Assembly, Conveyor Slide	1	
3	AB3170485	Support, Conveyor	1	
4	AB3170489	Brace, Conveyor	1	
5	AB3171721	Panel, Conveyor Hopper	1	
6	AA1541780	Motor, 6070 Conveyor Hydraulic	1	
6a	AA1621179	Kit, Hydraulic Motor Seal	1	
6b	AA0901800	Key, Conveyor Motor	1	
7	AA0900468	Cylinder, 2 x 28 x 1.125 Hydraulic	1	
7a	AA2148205	Kit, 2.0 x 1.13 Nitrotec Seal	1	
8	RC702605	Orifice, -06 SAE x 0.049" Hole Disc	1	
9	AA1700863	Valve, Pilot Check	1	
10	RC700979	Adapter, -06 MORFS, -06 MPT Straight	1	
11	RC700978	Adapter, -06 MORFS 1/4-18 MPT Straight	1	
12	RC700195	Elbow, -06 FORFS -06 MORFS 45°	1	
13	RC701027	Fitting, -06 MORB 3/8 FPT 90°	1	
14	RC700118	Elbow, -06 MORFS -06 MORB 90°	1	
15	RC700156	Tee, -06 ORFS Run Thru	1	
16	RC700084	Adapter, -08 MORFS -10 MORB Straight	2	
17	RC900084	Bolt, 5/16-18 x 3/4 Gr 5 YZ Hex	3	
18	RC900726	Washer, 5/16 YZ Lock	3	
19	RC902162	Washer, 5/16 SAE YZ Hard Flat	3	
20	RC900096	Bolt, 3/8-16 x 1-3/4 Gr 5 YZ Hex	1	
21	RC900677	Washer, 3/8 SAE YZ Hard Flat	2	
22	RC900583	Nut, 3/8-16 YZ Nylock	1	
23	RC901882	Bolt, 1/2-13 x 1-3/4 Gr 5 CZ Carriage	2	
24	RC900137	Bolt, 1/2-13 x 2 Gr 5 YZ Hex	2	
25	RC900691	Washer, 1/2 SAE YZ Hard Flat	6	
26	RC900588	Nut, 1/2-13 YZ Nylock	4	

2.5 – Hopper

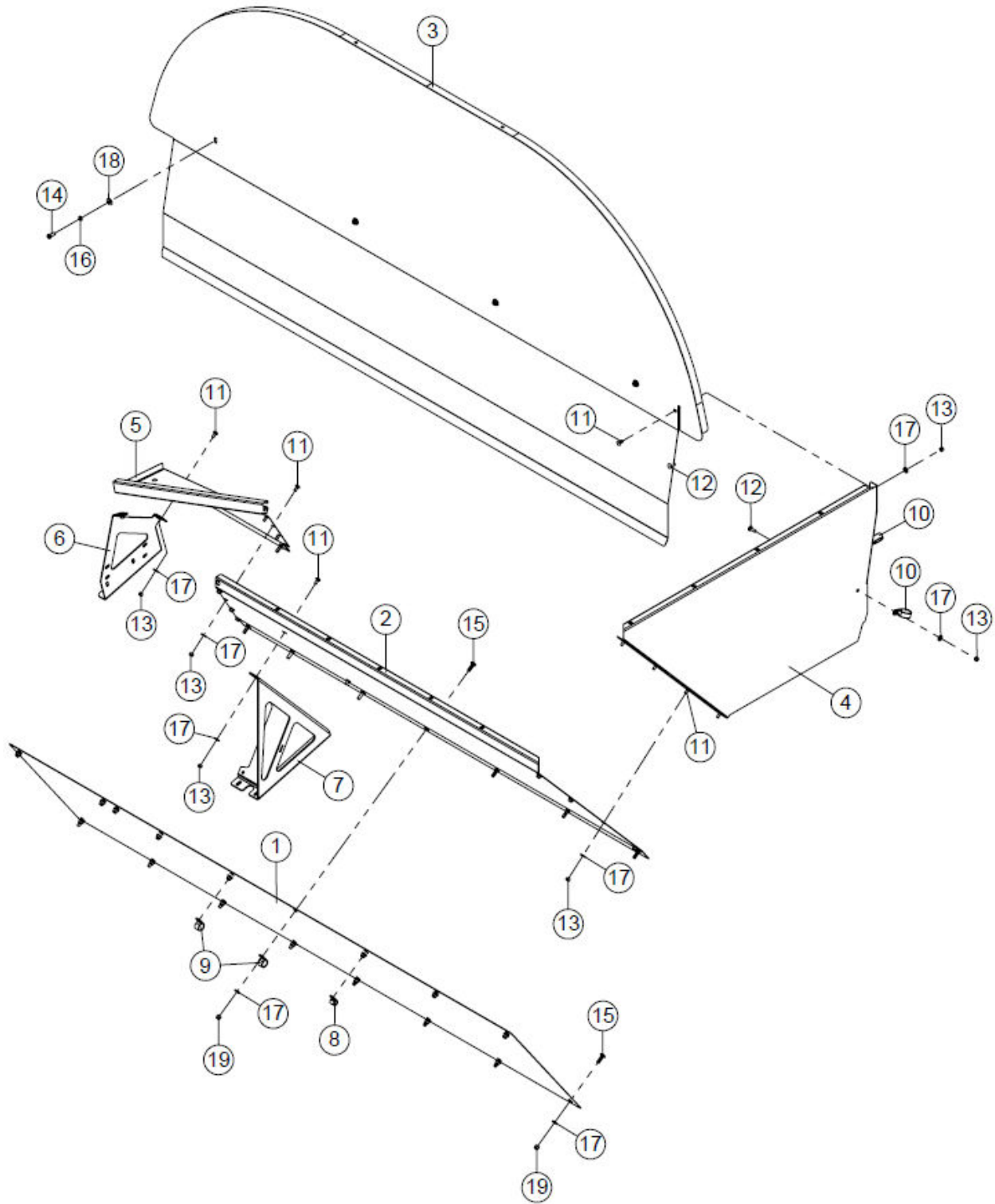

2.5 – Hopper

Key	Part Number	Description	Qty	Comments
1	AB3171484	Liner, T8088 Rotor Pan	1	
2	AB3171483	Panel, T8088 Front Left Hopper	1	
3	AB3172091	Panel, T8088 Rear Hopper	1	
4	AB3172088	Panel, T8088 LH Hopper	1	
5	AB3171724	Sheet, Hopper Filler	1	
6	AB3171715	Support, Hopper	1	
7	AB3172698	Brace, Hand Pump and Hopper	1	
8	RC902616	P-Clamp, 5/8 Cushion	1	
9	RC902064	P-Clamp, 1 Cushion	2	
10	RC901689	P-Clamp, 1-1/2 Cushion	2	
11	RC901023	Bolt, 5/16-18 x 3/4 SS Carriage	14	
12	RC900381	Bolt, 5/16-18 x 1 SS Carriage	2	
13	RC900579	Nut, 5/16-18 YZ Nylock	16	
14	RC900088	Bolt, 3/8-16 x 1 Gr 5 YZ Hex	4	
15	RC901032	Bolt, 3/8-16 x 1-1/4 SS Carriage	17	
16	RC900728	Washer, 3/8 YZ Lock	4	
17	RC900677	Washer, 3/8 SAE YZ Hard Flat	33	
18	RC902699	Washer, 3/8 USS YZ Hard Flat	4	
19	RC900583	Nut, 3/8-16 YZ Nylock	17	

3.1 – Tunnel Cleanout

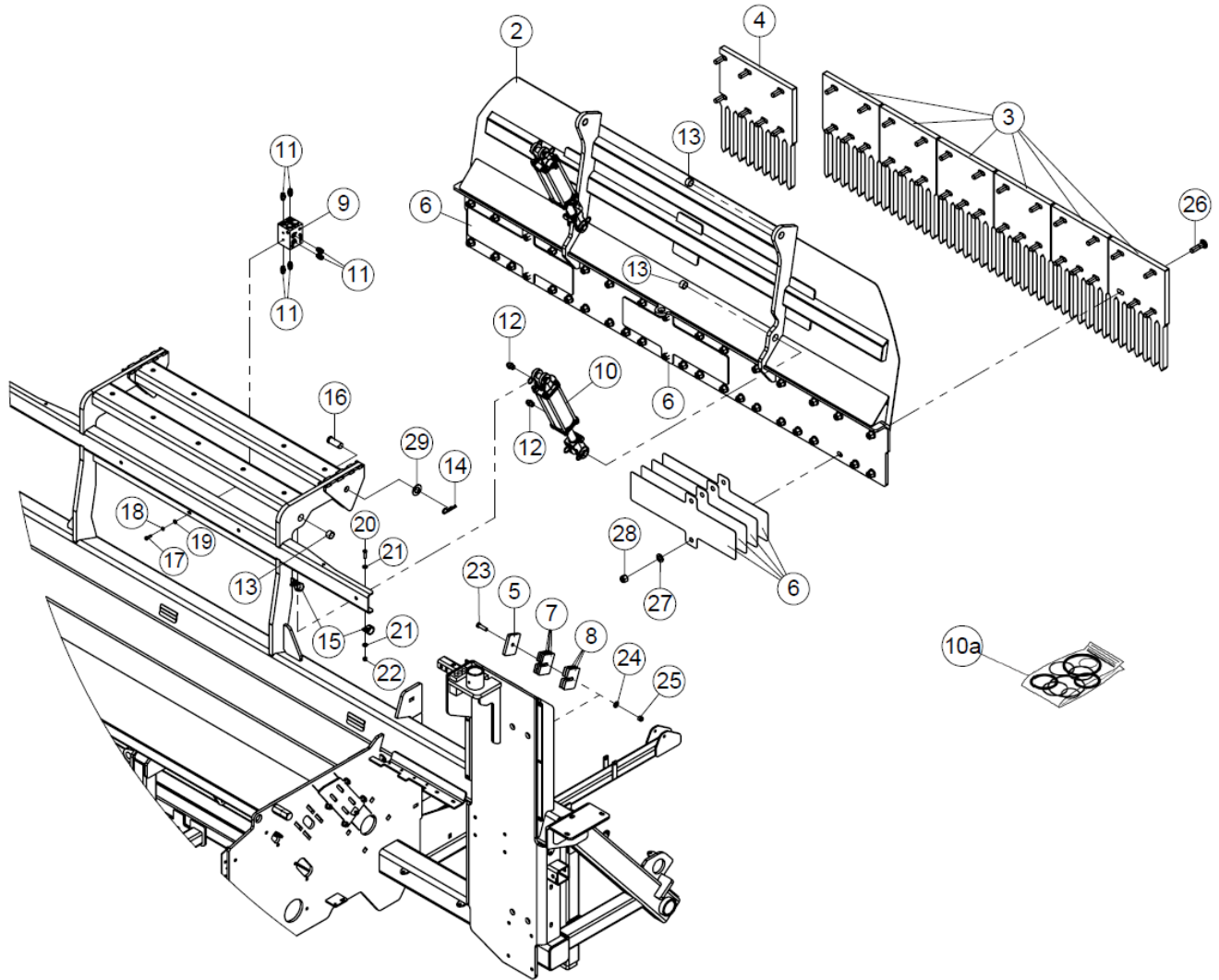

3.1 – Tunnel Cleanout

Key	Part Number	Description	Qty	Comments
1	AB3171358	Frame, T8088 Main	1	
2	AB3172094	Door, T8088 Cleanout	1	S/N 401096 - X
2a	AB3171386	Door, T8088 Cleanout	1	S/N up to 401095
3	AB3170626	Replacement, LH Stripper Bar Plate	6	
4	AB3171389	Plate, T8088 Stripper Bar	1	
5	AB3170264	Guide, Stripper Bar	2	
6	AB3170913	Shim, Stripper Bar	12	
7	AB3170265	Shim, Stripper Bar Guide	8	
8	AB3170912	Shim, .060" Stripper Bar Guide	6	
9	RC950603	Assembly, #06 ORB x 2 Flow Divider	1	See breakdown on Parts Page 10.8
10	RC950741	Cylinder, 3" x 8" Tie Rod	2	S/N 401096 - X
10a	RC950643	Kit, Cylinder Seal	1	S/N 401096 - X
10	RC950502	Cylinder, 3" x 4" Tie Rod	2	S/N up to 401095
10a	RC950643	Kit, Cylinder Seal	1	S/N up to 401095
11	RC700077	Adapter, -06 MORFS -06 MORB Straight	6	
12	RC700078	Adapter, -06 MORFS -08 MORB Straight	4	
13	RC950611	Bearing, 1" ID x 3/4" High Load Bronze Sleeve	6	
14	RC900897	Hairpin, .177 x 3-1/4 CZ	2	
15	RC902785	P-Clamp, 1-1/4 Cushion	2	
16	RC901610	Pin, 1 x 2-1/2 CZ Clevis	2	
17	RC900063	Bolt, 5/16-18 x 1 Gr 5 YZ Hex	2	
18	RC900726	Washer, 5/16 YZ Lock	2	
19	RC902162	Washer, 5/16 SAE YZ Hard Flat	2	
20	RC900091	Bolt, 3/8-16 x 1-1/4 Gr 5 YZ Hex	2	
21	RC900677	Washer, 3/8 SAE YZ Hard Flat	4	
22	RC900583	Nut, 3/8-16 YZ Nylock	2	
23	RC900136	Bolt, 1/2-13 x 1 3/4 Gr 5 YZ Hex	2	
24	RC900691	Washer, 1/2 SAE YZ Hard Flat	2	
25	RC900588	Nut, 1/2-13 YZ Nylock	2	
26	RC902766	Bolt, 3/4 x 3 Gr 5 CZ Carriage	37	
27	RC902416	Washer, 3/4 SAE YZ Hard Flat	37	
28	RC900597	Nut, 3/4-10 YZ Nylock	37	
29	RC900708	Washer, 1 SAE YZ Hard Flat	2	

4.1 – 10' Tunnel

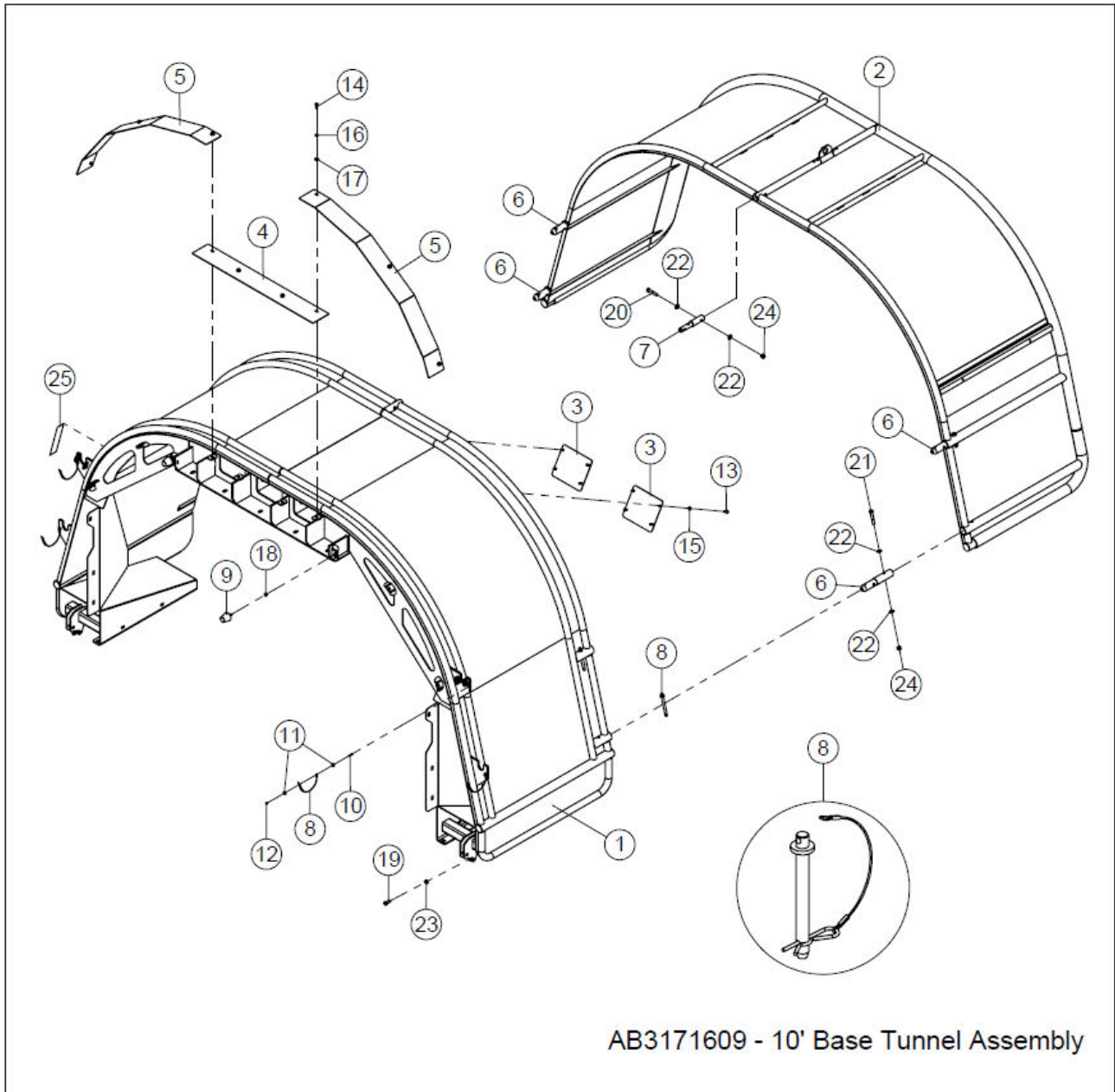

4.1 – 10' Tunnel

Key	Part Number	Description	Qty	Comments
1	AB3171598	Tunnel, 10' Base	1	
2	AB3171606	Extension, 10' End	1	
3	AB3171608	Plate, Tunnel Access	2	
4	AB3172105	Cover, Upper Cleanout	1	
5	AB3172107	Cover, 10' Tunnel Side	2	
6	AB3171570	Pin, YZ Tunnel	4	
7	AB3171074	Pin, YZ Extension	1	
8	AB3170998	Pin/Lanyard, Tunnel	4	Pins come with lanyard
9	RC902805	Bumper, 3/8-16 x 1-1/4 Black Threaded Stud	2	
10	RC900474	Screw, #10-24 x 1 CZ Hex	4	
11	RC902870	Washer, #10 CZ Fender	8	
12	RC902420	Nut, #10-24 YZ Nylock	4	
13	RC901091	Screw, 3/8-16 x 1 SS Button Head Socket	8	
14	RC900088	Bolt, 3/8-16 x 1 Gr 5 YZ Hex	8	
15	RC901166	Washer, 3/8 SS Lock	8	
16	RC900728	Washer, 3/8 YZ Lock	8	
17	RC900677	Washer, 3/8 SAE YZ Hard Flat	8	
18	RC900524	Nut, 3/8-16 YZ Hex	2	
19	RC900133	Bolt, 1/2-13 x 1-1/4 Gr 5 YZ Hex	2	
20	RC900284	Bolt, 1/2-13 x 2-1/2 Gr 8 YZ Hex	1	
21	RC901743	Bolt, 1/2-13 x 3 Gr 8 YZ Hex	4	
22	RC900691	Washer, 1/2 SAE YZ Hard Flat	10	
23	RC900612	Nut, 1/2-13 YZ Hex Jam	2	
24	RC900588	Nut, 1/2-13 YZ Nylock	5	
25	RC901939	Reflector, Yellow 2 x 9	1	

4.2 – 12' Tunnel

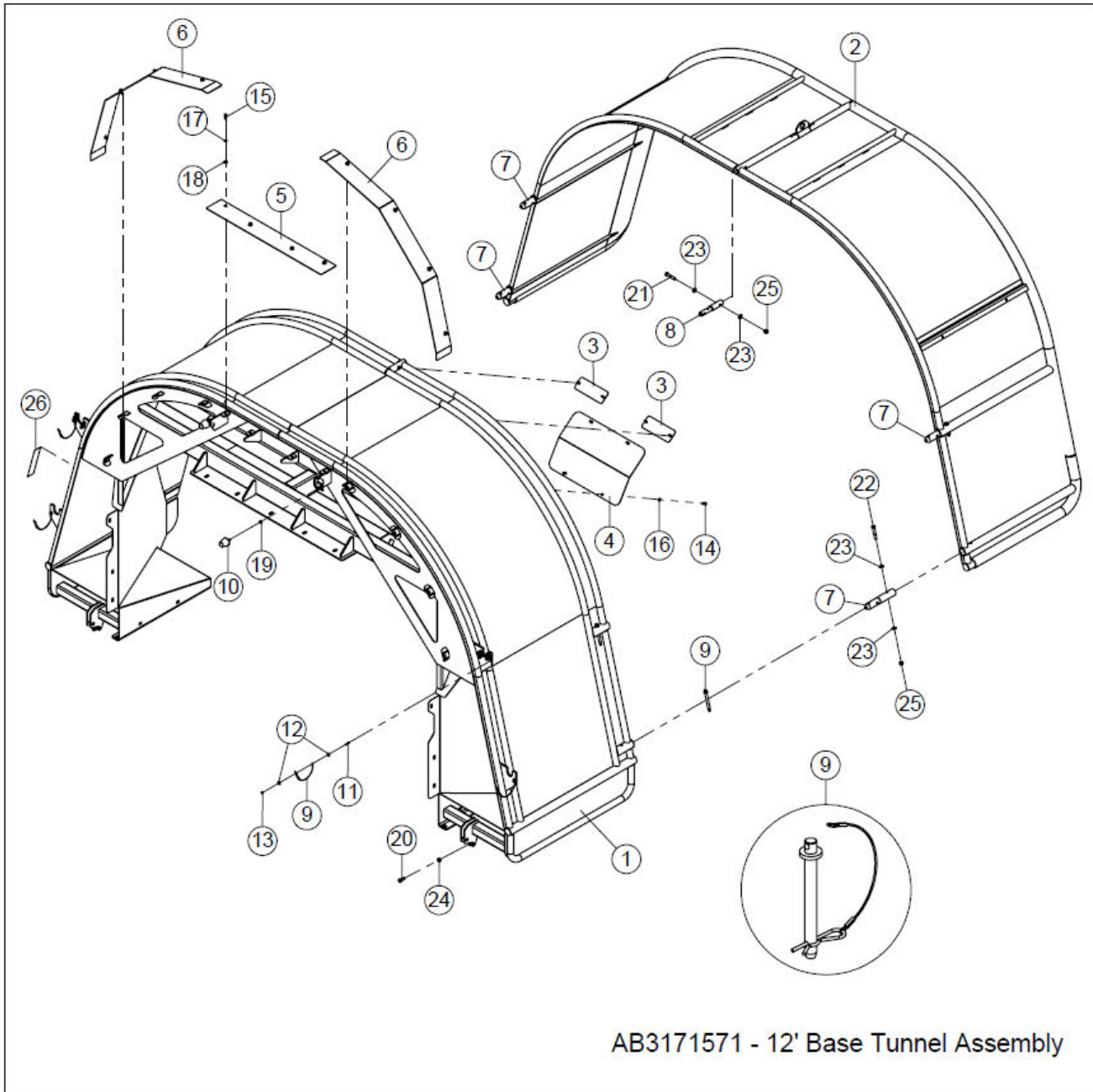

4.2 – 12' Tunnel

Key	Part Number	Description	Qty	Comments
1	AB3171550	Tunnel, 12' Base	1	
2	AB3171568	Extension, 12' End	1	
3	AB3170554	Plate, Fork Access Door	2	
4	AB3171552	Cover, Tunnel Access	1	
5	AB3172105	Cover, Upper Cleanout	1	
6	AB3172114	Cover, 12' Tunnel Side	2	
7	AB3171570	Pin, YZ Tunnel	4	
8	AB3171074	Pin, YZ Extension	1	
9	AB3170998	Pin/Lanyard, Tunnel	4	Pins come with lanyard
10	RC902805	Bumper, 3/8-16 x 1-1/4 Black Threaded Stud	2	
11	RC900474	Screw, #10-24 x 1 CZ Hex	4	
12	RC902870	Washer, #10 CZ Fender	8	
13	RC902420	Nut, #10-24 YZ Nylock	4	
14	RC901091	Screw, 3/8-16 x 1 SS Button Head Socket	8	
15	RC900088	Bolt, 3/8-16 x 1 Gr 5 YZ Hex	12	
16	RC901166	Washer, 3/8 SS Lock	8	
17	RC900728	Washer, 3/8 YZ Lock	12	
18	RC900677	Washer, 3/8 SAE YZ Hard Flat	12	
19	RC900524	Nut, 3/8-16 YZ Hex	2	
20	RC900133	Bolt, 1/2-13 x 1-1/4 Gr 5 YZ Hex	2	
21	RC900284	Bolt, 1/2-13 x 2-1/2 Gr 8 YZ Hex	1	
22	RC901743	Bolt, 1/2-13 x 3 Gr 8 YZ Hex	4	
23	RC900691	Washer, 1/2 SAE YZ Hard Flat	10	
24	RC900612	Nut, 1/2-13 YZ Hex Jam	2	
25	RC900588	Nut, 1/2-13 YZ Nylock	5	
26	RC901939	Reflector, Yellow 2 x 9	1	

4.3 – Tunnel Mounting

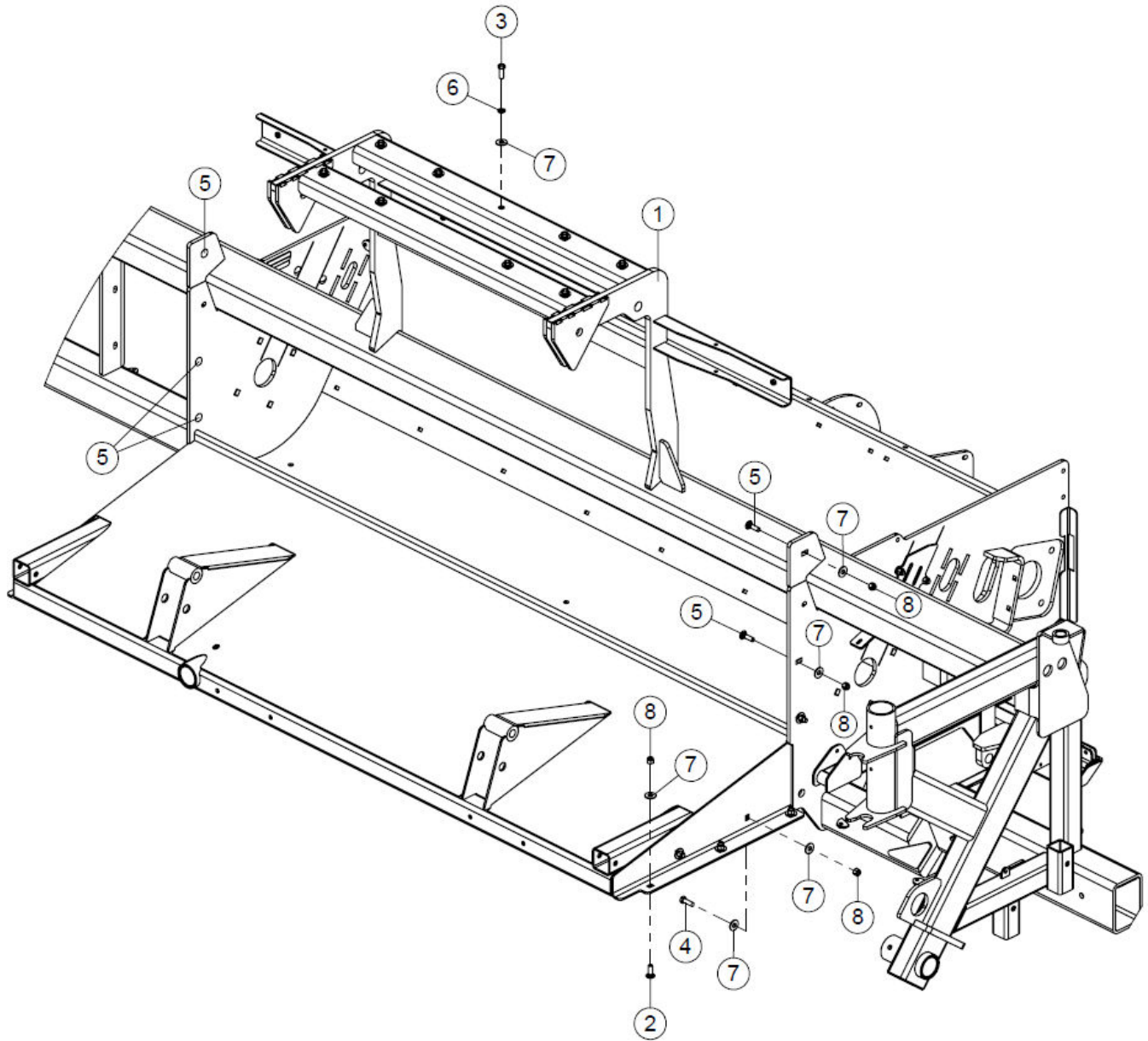

4.3 – Tunnel Mounting

Key	Part Number	Description	Qty	Comments
1	AB3171358	Frame, T8088 Main	1	
2	RC902769	Bolt, 1/2-13 x 1-1/2 Gr 5 CZ Carriage	6	
3	RC900135	Bolt, 1/2-13 x 1-1/2 Gr 5 YZ Hex	9	
4	RC900282	Bolt, 1/2-13 x 1-1/2 Gr 8 YZ Hex	4	
5	RC901882	Bolt, 1/2-13 x 1-3/4 Gr 5 CZ Carriage	6	
6	RC900731	Washer, 1/2 YZ Lock	9	
7	RC900689	Washer, 1/2 USS YZ Hard Flat	29	
8	RC900588	Nut, 1/2-13 YZ Nylock	16	

4.4 – Bag Boom

Key	Part Number	Description	Qty	Comments
1	AB3170438	Vertical Frame, Bag Boom	1	
2	AB3170440	Horizontal Frame, Bag Boom	1	
3	AA0900397	Winch, Brake DLB1500A	1	
4	AA2121349	Top Link, Cat 2 Hitch	1	
5	AB3170436	Pulley Mount, Bag Boom	1	
6	AA1060036	Pulley, Bag Boom 3 in.	2	
7	AA1501691	Cable, 1/4 X 30 ft w/Hook	1	
8	AB3170442	Handle, Boom	1	
9	AB3170618	Bushing, Boom	1	
10	RC950190	Bushing, 1" ID x 1" Sleeve	2	
11	RC901679	Bushing, 1 x 14 Ga YZ Machinery	1	
12	AB3170606	Pin, Pivot Crane	1	
13	RC901875	Ring, 1 BP HD External Snap	1	
14	RC900834	Pin, 3/16 x 2 CZ Cotter	2	
15	RC902595	Pin, 3/8 x 2-1/2 CZ Square Retainer	1	
16	RC902779	Pin, 3/4 x 5 CZ Bent Pull Hitch	1	
17	RC902648	Pin, 1 x 3-1/2 CZ Clevis	2	
18	RC900091	Bolt, 3/8-16 x 1-1/4 Gr 5 YZ Hex	3	
19	RC900100	Bolt, 3/8-16 x 2-1/4 Gr5 YZ Hex	1	
20	RC900104	Bolt, 3/8-16 x 3 Gr 5 YZ Hex	1	
21	RC900677	Washer, 3/8 SAE YZ Hard Flat	10	
22	RC900583	Nut, 3/8-16 YZ Nylock	5	
23	RC900174	Bolt, 5/8-11 x 2-3/4 Gr 5 YZ Hex	1	
24	RC900175	Bolt, 5/8-11 x 3 Gr 5 YZ Hex	1	
25	RC900694	Washer, 5/8 SAE YZ Hard Flat	4	
26	RC900593	Nut, 5/8-11 YZ Nylock	2	
27	RC900708	Washer, 1 SAE YZ Hard Flat	2	

4.5 – Cradle

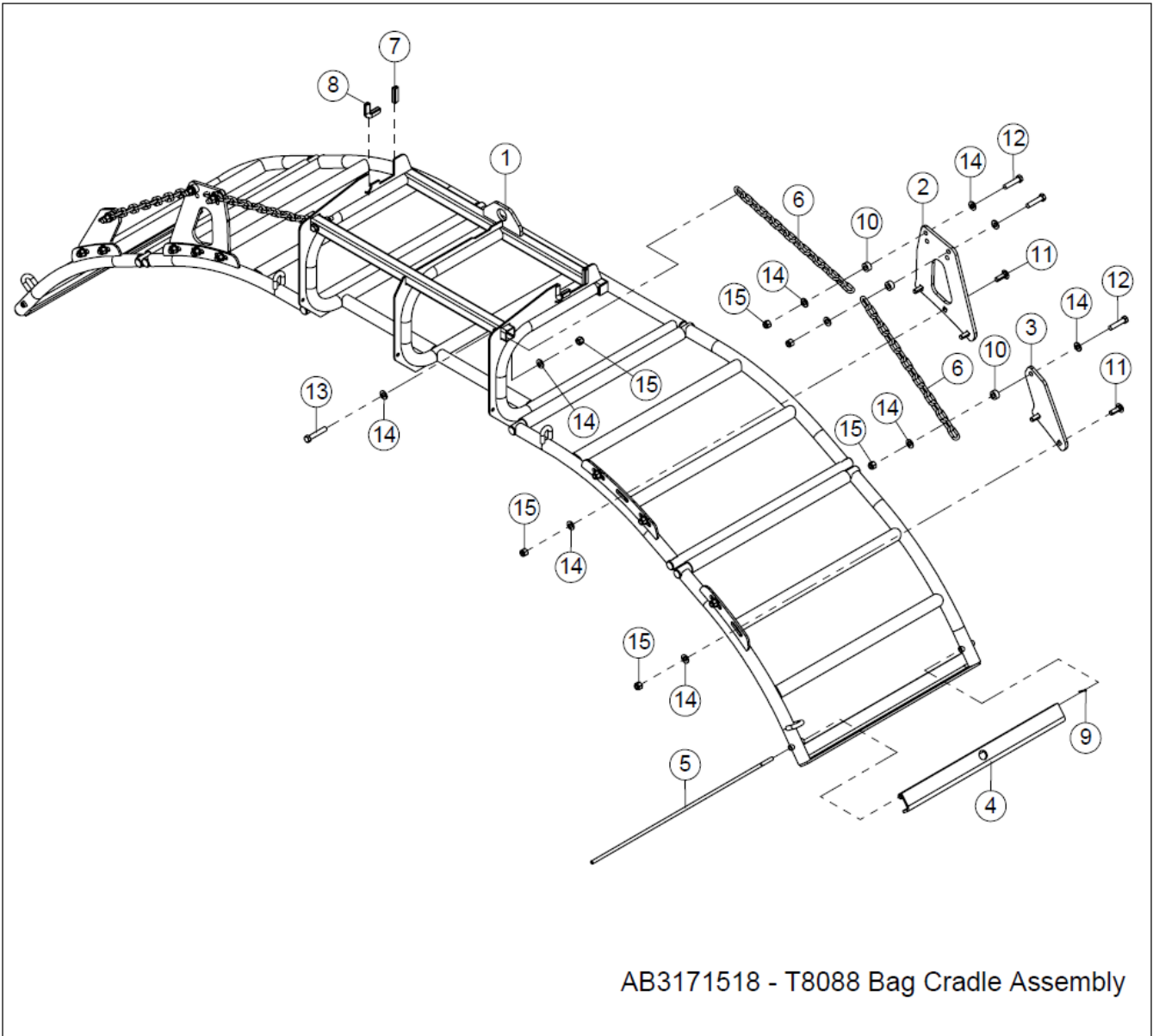

4.5 – Cradle

Key	Part Number	Description	Qty	Comments
1	AB3171517	Cradle, T8088 Bag	1	
2	AB3171505	Bracket, Upper Cradle Chain	2	
3	AB3171506	Bracket, Lower Cradle Chain	2	
4	AB3171934	Hook, Cradle	2	
5	AB3171936	Rod, Cradle Hinge	2	
6	RC950712	Chain, 1/4 Grade 43 x 15 Links	4	
7	AB3170989	Trim, 2" C.L. Edge	2	
8	AB3170997	Trim, 3" C.L. Edge	2	
9	RC900839	Pin, 1/8 x 1 YZ Cotter	2	
10	RC902481	Spacer, .505" ID x 1.00" OD x 1/2" CZ	6	
11	RC902769	Bolt, 1/2-13 x 1-1/2 Gr 5 CZ Carriage	10	
12	RC900139	Bolt, 1/2-13 x 2-1/4 Gr 5 YZ Hex	6	
13	RC900141	Bolt, 1/2-13 x 2-3/4 Gr 5 YZ Hex	2	
14	RC900691	Washer, 1/2 SAE YZ Hard Flat	26	
15	RC900588	Nut, 1/2-13 YZ Nylock	18	

5.1 – Anchors

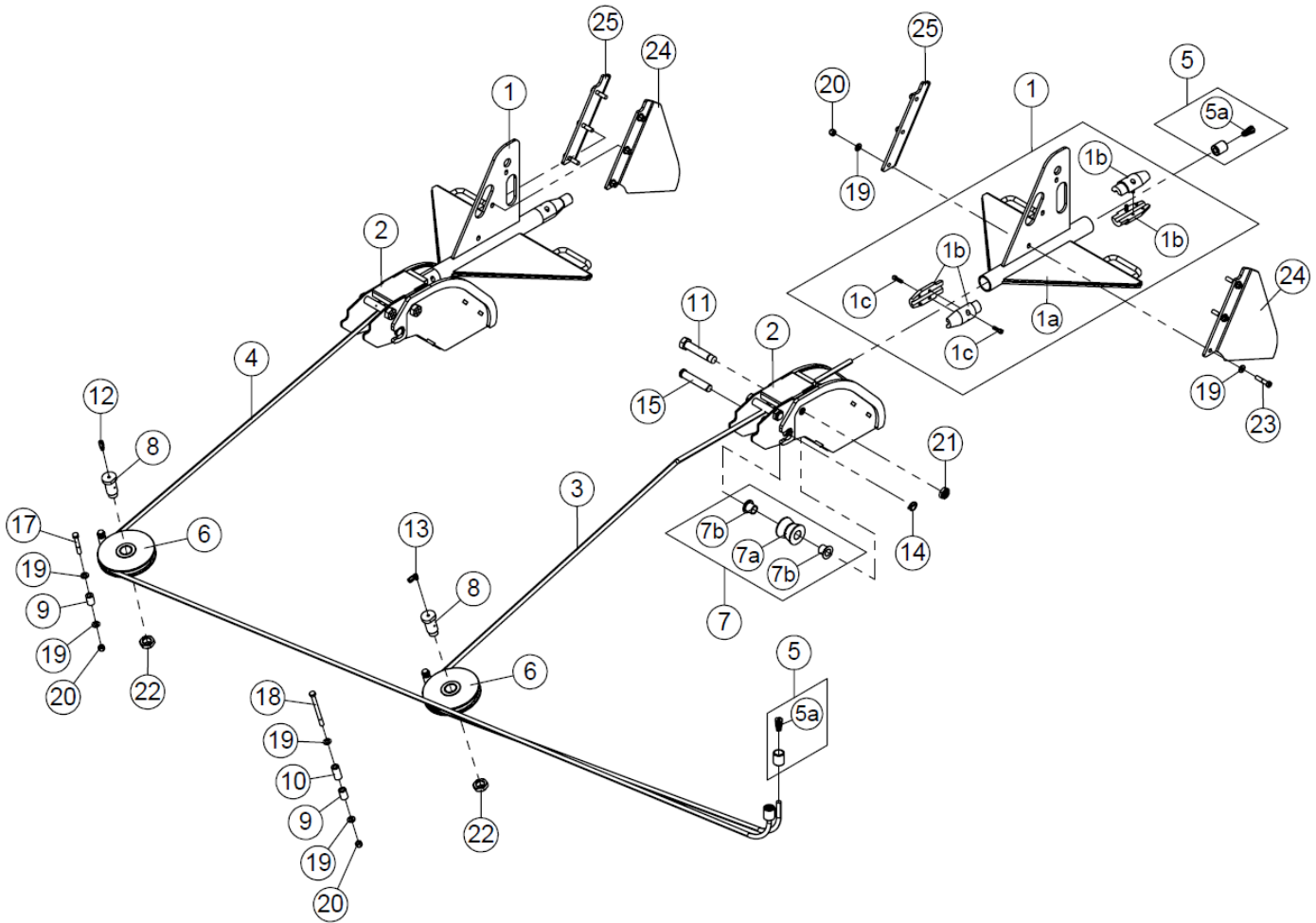

5.1 – Anchors

Key	Part Number	Description	Qty	Comments
1	AA3160105	Kit, Compaction Anchor	2	
1a	AA0803265	Anchor, Compaction	1	
1b	AA0802129	Stop, Cable Half	4	
1c	RC902705	Screw, 3/8-16 x 1-1/4 BO SH Cap	4	
2	AB3171859	Support, Anchor	2	
3	AA1590059	Cable, 5/8" X 30' Blank Ends	1	
4	AA1590058	Cable, 5/8" X 35' Blank Ends	1	
5	AA1501401	Knob, Quick D5	4	
5a	AA1501766	Wedge, D5 Quick Knob	1	
6	AA1060156	Pulley, Anchor Large 1-1/2	2	
7	AA0802304	Roller, Anchor w/Bushing	2	
7a	AA0901318	Roller, YZ Anchor Cable	1	
7b	AA900695	Bearing, 1.253 X 1.25 X 1.001 ID Sleeve	2	
8	AA1060163	Pin, Anchor Cylinder Outlet Pulley	2	
9	AB3171685	Spacer, Pulley Mount	4	
10	AB3171885	Spacer, Upper Pulley	1	
11	AA1206076	Bolt, Anchor Fairlead 1"	4	
12	RC702704	Adapter, Straight 1/4" Tube to 1/8"-27 MPT	1	
13	RC703162	Adapter, 1/4" Tube to 1/8" MPT 90 Deg	1	
14	RC902889	Pin, 3/16 x 1 CZ Linch	2	
15	RC902627	Pin, 1 x 5 CZ Clevis	2	
16	RC902080	Zerk, 1/4-28 UNF Straight Grease	4	
17	RC900144	Bolt, 1/2-13 x 3-1/4 Gr 5 YZ Hex	3	
18	RC900153	Bolt, 1/2-13 x 6 Gr5 YZ Hex	1	
19	RC900691	Washer, 1/2 SAE YZ Hard Flat	20	
20	RC900588	Nut, 1/2-13 YZ Nylock	10	
21	RC902817	Nut, 1-8 CZ Nylock Jam	4	
22	RC902747	Nut, 1 1/4-7 CZ Hex Jam	2	
23	RC900283	Bolt, 1/2-13 x 2-1/4 Gr 8 YZ Hex	6	<u>Optional</u> - See Operating the Unit Section
24	AB3172712	Fin, LH Anchor	2	<u>Optional</u> - See Operating the Unit Section
25	AB3172713	Fin, RH Anchor	2	<u>Optional</u> - See Operating the Unit Section

5.2 – Anchor Cylinder

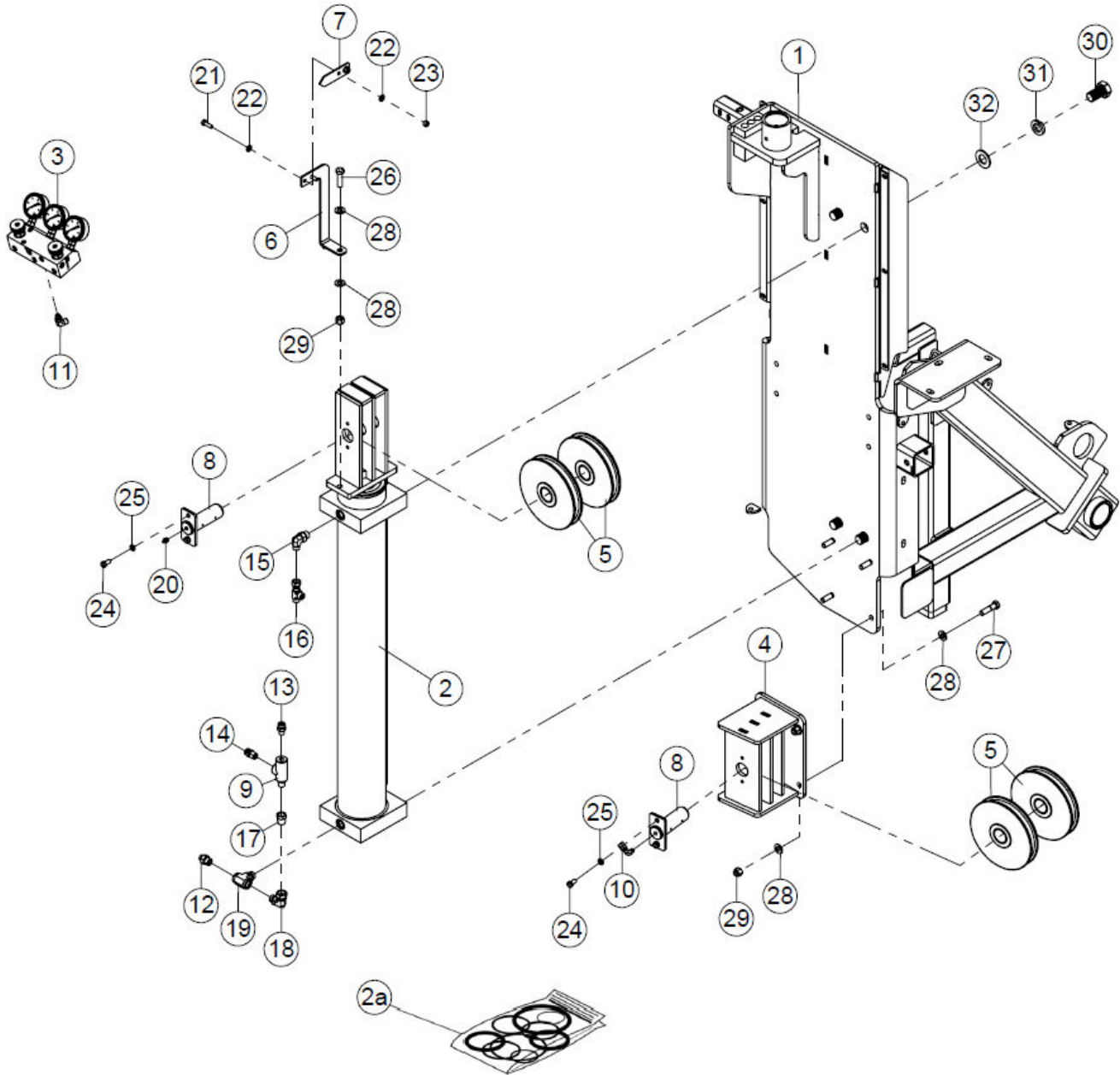

5.2 – Anchor Cylinder

Key	Part Number	Description	Qty	Comments
1	AB3171358	Frame, T8088 Main	1	
2	AB3171937	Cylinder, Dual Anchor	1	
2a	AB3172135	Kit, Cylinder Seal	1	
3	AB3172575	Assembly, Brake Hand Pump Gauge Station	1	See breakdown on Parts Page 10.10
4	AB3171870	Bracket, Pulley	1	
5	AA1060156	Pulley, Anchor Large 1-1/2	4	
6	AB3171492	Indicator, Anchor Position	1	
7	AB3171898	Arrow, Anchor Cylinder Depth Indicator	1	
8	AA1030091	Pin, Short Anchor Cyl	2	
9	AA1700863	Valve, Pilot Check	1	
10	RC703162	Adapter, 1/4" Tube to 1/8" MPT 90 Deg	1	
11	RC700114	Elbow, -04 MORFS -04 MORB 90°	1	
12	RC700075	Adapter, -04 MORFS -08 MORB Straight	1	
13	RC700978	Adapter, -06 MORFS 1/4-18 MPT Straight	1	
14	RC700979	Adapter, -06 MORFS, -06 MPT Straight	1	
15	RC700119	Elbow, -06 MORFS -08 MORB 90°	1	
16	RC700156	Tee, -06 ORFS Run Thru	1	
17	RC701272	Bushing, 1/2 MPT 3/8 FPT Reducer	1	
18	RC701516	Elbow, -08 MORB 1/2 FPT Swivel 90°	1	
19	RC702612	Tee, -08 MORB Branch	1	
20	RC901873	Zerk, 1/8 NPT Straight Grease	1	
21	RC900063	Bolt, 5/16-18 x 1 Gr 5 YZ Hex	2	
22	RC902162	Washer, 5/16 SAE YZ Hard Flat	4	
23	RC900579	Nut, 5/16-18 YZ Nylock	2	
24	RC900119	Bolt, 3/8-16 x 3/4 Gr 5 YZ Hex	4	
25	RC900728	Washer, 3/8 YZ Lock	4	
26	RC900136	Bolt, 1/2-13 x 1 3/4 Gr 5 YZ Hex	1	
27	RC901364	Bolt, 1/2-13 x 2 Gr 8 YZ Hex	4	
28	RC900691	Washer, 1/2 SAE YZ Hard Flat	10	
29	RC900588	Nut, 1/2-13 YZ Nylock	5	
30	RC902892	Bolt, 1-14 x 1-3/4 Gr 8 YZ Hex	4	
31	RC900738	Washer, 1 YZ Lock	4	
32	RC900708	Washer, 1 SAE YZ Hard Flat	4	

5.3 – Anchor Take-up

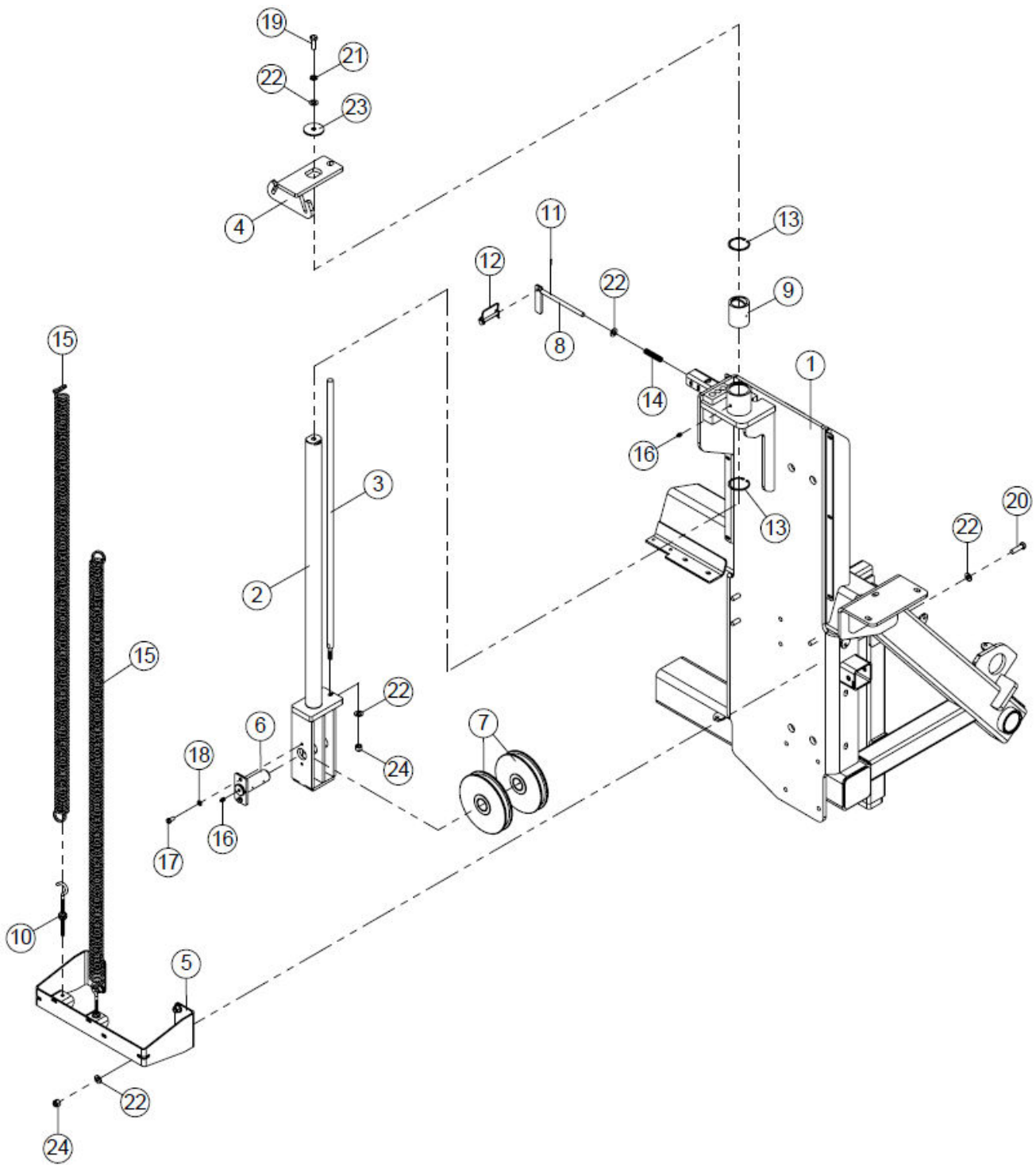

5.3 – Anchor Take-up

Key	Part Number	Description	Qty	Comments
1	AB3171358	Frame, T8088 Main	1	
2	AB3171920	Take-up, Dual Anchor	1	
3	AB3171642	Rod, Take-up Guide	1	
4	AB3171640	Mount, Take-up Spring	1	
5	AB3171889	Bracket, Spring Tension	1	
6	AA1030091	Pin, Short Anchor Cylinder	1	
7	AA1060156	Pulley, Anchor Large 1-1/2	2	
8	AB3171973	Handle, YZ Lockout	1	
9	RC950705	Bearing, 2" ID x 3" Bronze Sleeve	1	
10	RC902856	Hook, 3/8-16 x 8 CZ Screw-In	2	
11	RC902852	Pin, 1/8 x 3/4 Plain Roll	1	
12	RC902595	Pin, 3/8 x 2-1/2 CZ Locking Square Retainer	1	
13	RC902854	Ring, 2-1/2 YZ Internal Snap	2	
14	RC950733	Spring, 5/8 OD x 2-3/4 Compression	1	
15	RC950711	Spring, 25" x 160 lbs Extension	2	
16	RC901873	Zerk, 1/8 NPT Straight Grease	2	
17	RC900119	Bolt, 3/8-16 x 3/4 Gr 5 YZ Hex	2	
18	RC900728	Washer, 3/8 YZ Lock	2	
19	RC900135	Bolt, 1/2-13 x 1-1/2 Gr 5 YZ Hex	1	
20	RC900136	Bolt, 1/2-13 x 1 3/4 Gr 5 YZ Hex	4	
21	RC900731	Washer, 1/2 YZ Lock	1	
22	RC900691	Washer, 1/2 SAE YZ Hard Flat	11	
23	RC902586	Washer, 1/2 x 2-1/2 O.D. Black Pivot Pin	1	
24	RC900588	Nut, 1/2-13 YZ Nylock	5	

5.4 – Anchor Cylinder & Take-up Enclosure

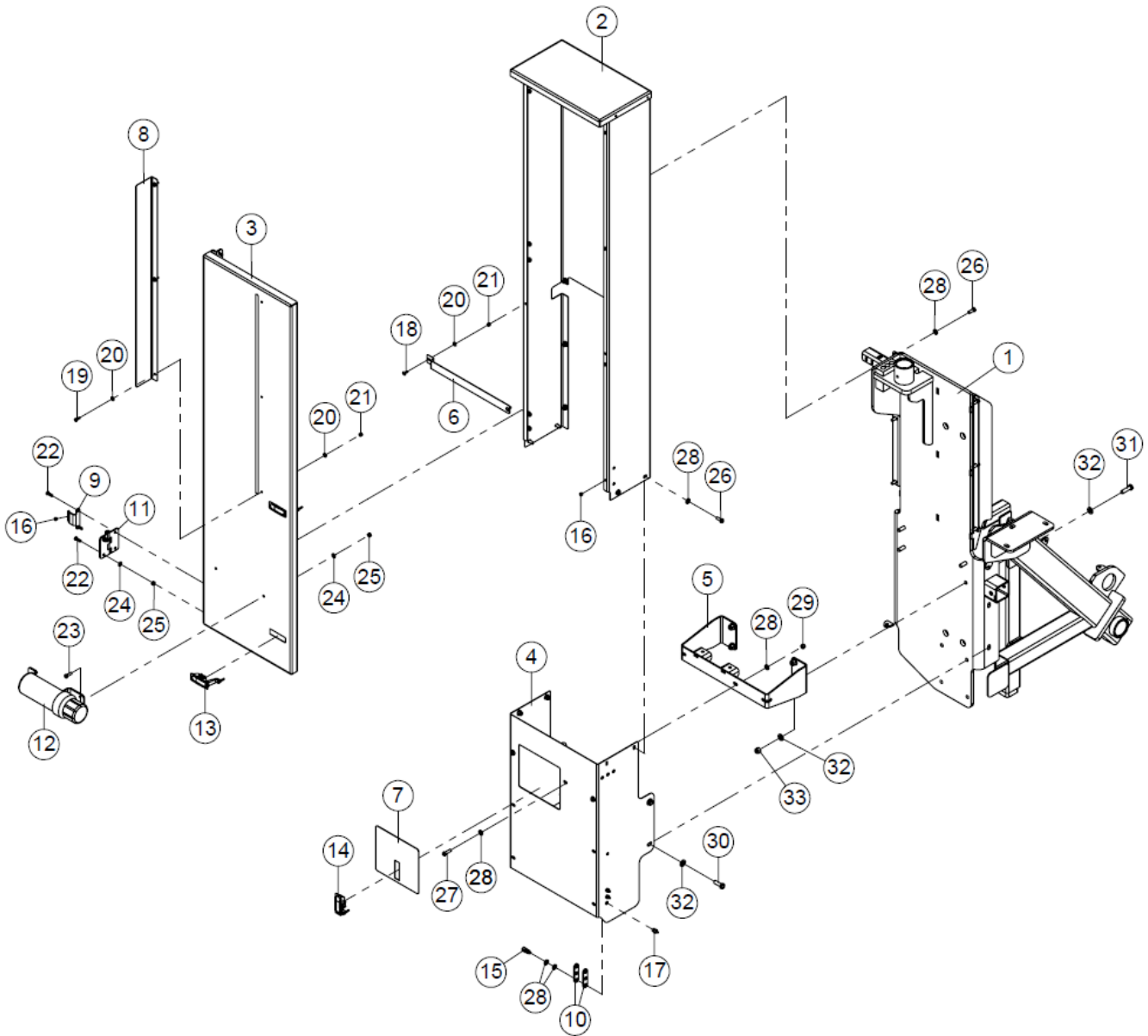

5.4 – Anchor Cylinder & Take-up Enclosure

Key	Part Number	Description	Qty	Comments
1	AB3171358	Frame, T8088 Main	1	
2	AB3171394	Enclosure, Anchor Cyl	1	
3	AB3171397	Door, Anchor Cyl Cover	1	
4	AB3171401	Cover, Lower Anchor Cyl	1	
5	AB3171889	Bracket, Spring Tension	1	
6	AB3171918	Strap, Anchor Compartment	1	
7	AB3171433	Cover, Tensioner Access	1	
8	AB3171399	Indicator, Anchor Cyl	1	
9	AB3171688	Stop, Anchor Cyl Door	2	
10	AB3171674	Spacer, Grease Fitting	2	
11	AB3171390	Hinge, .188" x 4" x 4" Blue	3	
12	RC950460	Holder, Manual	1	
13	RC950075	Latch, Lever	2	
14	RC950076	Latch, Lever	1	
15	RC702704	Adapter, Straight ¼" Tube to 1/8"-27 MPT	3	
16	RC902772	Bumper, 7/16 x 3/16 Push-In Rubber	6	
17	RC901968	Zerk, 1/8-27 FPT Straight Grease	3	
18	RC902377	Bolt, 1/4-20 x 3/4 CZ Gr 5 Carriage	2	
19	RC901956	Bolt, 1/4-20 x 3/4 Gr 5 YZ Hex	3	
20	RC902696	Washer, 1/4 SAE YZ Hard Flat	8	
21	RC900575	Nut, 1/4-20 YZ Nylock	5	
22	RC901632	Screw, 5/16-18 x 1 CZ Button Head Socket	12	
23	RC900063	Bolt, 5/16-18 x 1 Gr 5 YZ Hex	2	
24	RC902162	Washer, 5/16 SAE YZ Hard Flat	15	
25	RC900579	Nut, 5/16-18 YZ Nylock	14	
26	RC900088	Bolt, 3/8-16 x 1 Gr 5 YZ Hex	10	
27	RC900091	Bolt, 3/8-16 x 1-1/4 Gr 5 YZ Hex	3	
28	RC900677	Washer, 3/8 SAE YZ Hard Flat	32	
29	RC900583	Nut, 3/8-16 YZ Nylock	13	
30	RC900135	Bolt, 1/2-13 x 1-1/2 Gr 5 YZ Hex	4	
31	RC900136	Bolt, 1/2-13 x 1 3/4 Gr 5 YZ Hex	4	
32	RC900691	Washer, 1/2 SAE YZ Hard Flat	16	
33	RC900588	Nut, 1/2-13 YZ Nylock	8	

6.1 – Bag Pan

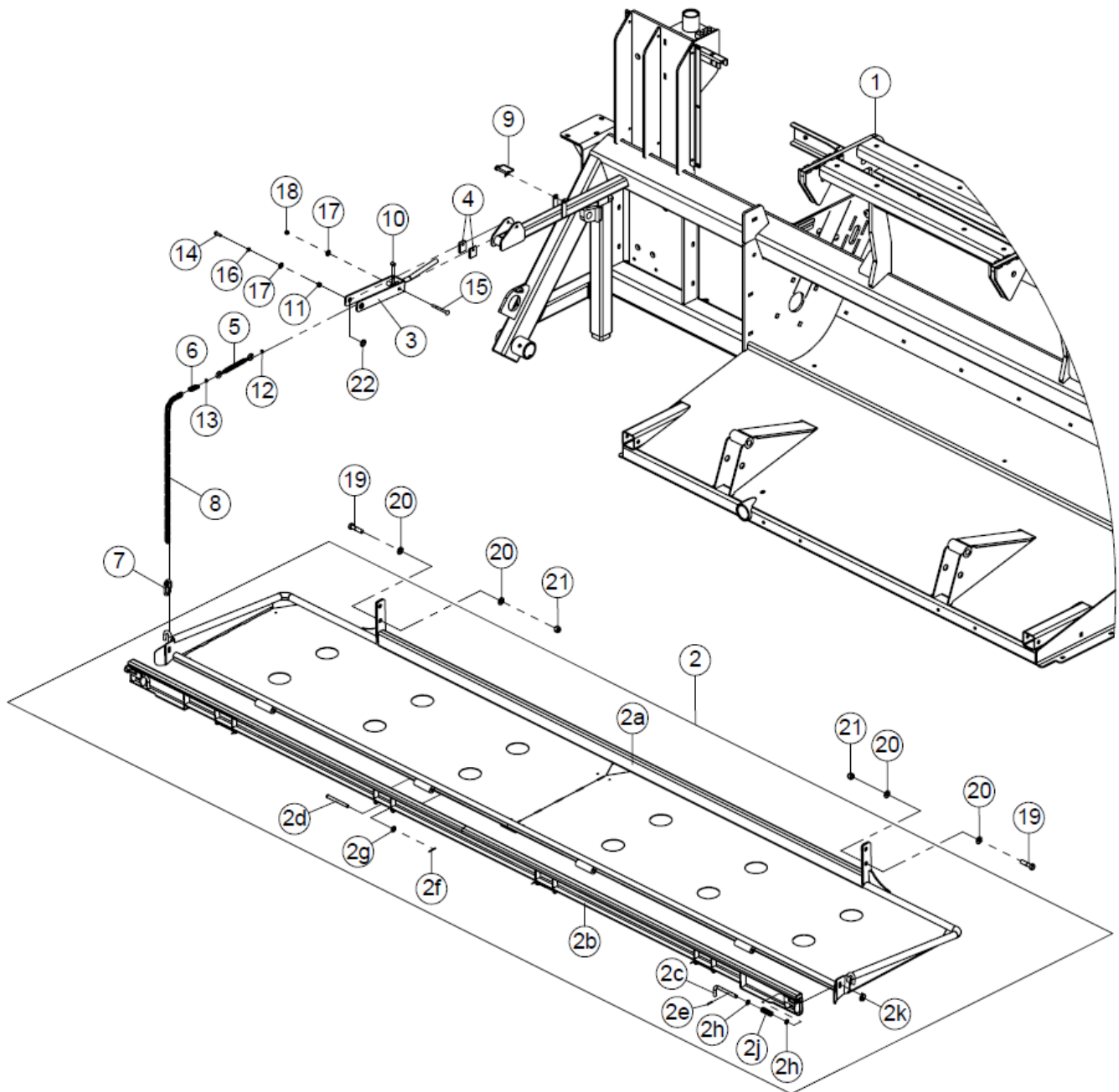

6.1 – Bag Pan

Key	Part Number	Description	Qty	Comments
1	AB3171358	Frame, T8088 Main	1	
2	AB3171830	Assembly, 12 ft Bag Pan	1	
2a	AB3171829	Bag Pan, 12 ft	1	
2b	AB3171818	Door, Bag Pan	1	
2c	AA1700750	Pin, Cam Lever	2	S/N 401099 - X
2c	AB3171376	Pin, Bag Pan Door	2	S/N up to 401098
2d	RC902851	Pin, 1/2 x 5 CZ Clevis	4	
2e	RC902761	Pin, 5/32 x 1-1/4 CZ Roll	2	
2f	RC900842	Pin, 1/8 x 1-1/4 YZ Cotter	4	
2g	RC900686	Washer, 1/2 SAE YZ Flat	4	
2h	RC902770	Washer, 1/2 x 14 Ga CZ Machinery Bushing	4	
2j	AA0717764	Spring	2	
2k	RC902889	Pin, 3/16 x 1 CZ Linch	2	
3	AB3171420	Lever, Bag Pan	2	
4	AB3171687	Nut, Lever Pivot	4	
5	RC950704	Turnbuckle, 5/16-18 x 4-1/2 Galvanized	2	
6	RC950706	Link, 1/4 x 1-3/4 CZ Chain	2	
7	RC950749	Link, 3/8 CZ Quick Chain	2	
8	RC950710	Chain, 1/4 CZ Grade 43 x 26 Links	2	
9	RC902595	Pin, 3/8 x 2-1/2 CZ Locking Square Retainer	2	
10	RC902862	Spacer, .380" ID x 9/16" OD x 5/8" Slotted CZ	2	
11	RC902217	Spacer, 3/8 I.D x 3/4 O.D x 3/8	4	
12	RC902831	Nut, 5/16-18 CZ Jam	2	
13	RC902888	Nut, 5/16-18 LH CZ Jam	2	
14	RC902861	Screw, 3/8-16 x 1-1/4 CZ Button Head Socket	4	
15	RC902858	Bolt, 3/8-16 x 3-3/4 CZ Carriage	2	
16	RC900728	Washer, 3/8 YZ Lock	4	
17	RC902699	Washer, 3/8 USS YZ Hard Flat	6	
18	RC900583	Nut, 3/8-16 YZ Nylock	2	
19	RC900172	Bolt, 5/8-11 x 2-1/2 Gr 5 YZ Hex	2	
20	RC900694	Washer, 5/8 SAE YZ Hard Flat	4	
21	RC900593	Nut, 5/8-11 YZ Nylock	2	
22	RC902996	Bushing, 3/4 x 14 Ga YZ Machinery	2	

7.1 – Shields

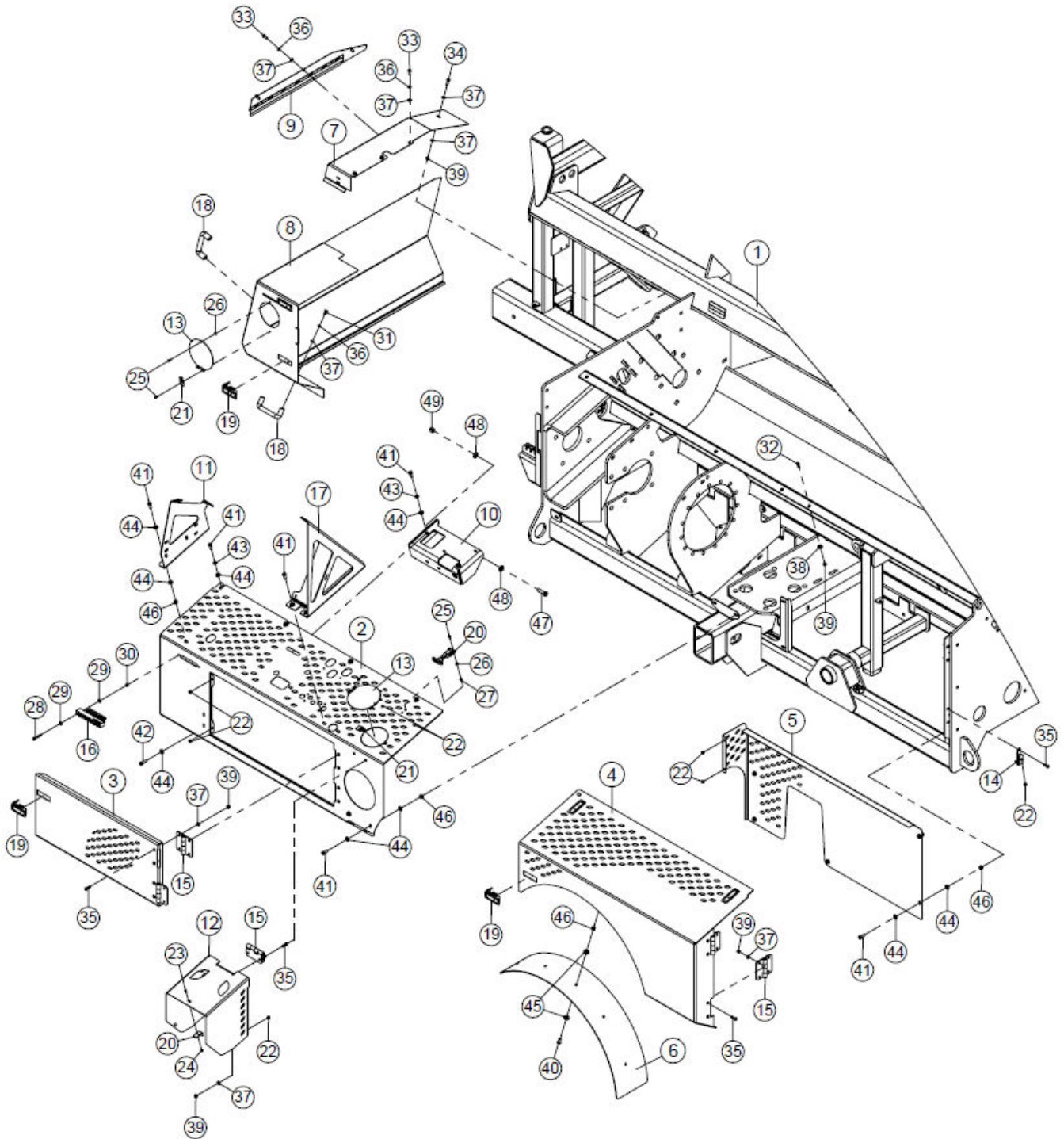

7.1 – Shields

Key	Part Number	Description	Qty	Comments
1	AB3171358	Frame, T8088 Main	1	
2	AB3171404	Shield, T8088 Control	1	
3	AB3170396	Door, T7170 Front Access	1	
4	AB3171412	Cover, T8088 Wheel	1	
5	AB3171245	Cover, Inner Wheel	1	
6	AB3170385	Liner, Wheel Well	1	
7	AB3170551	Cover, Upper Drive	1	
8	AB3171171	Cover, Lower Drive	1	
9	AB3170574	Cover, Side Drive	1	
10	AB3171167	Bracket, Hand Valve Mount	1	
11	AB3171715	Support, Hopper	1	
12	AB3170388	Shield, PTO	1	
13	AB3170403	Cover, Gearbox Oil Access	2	
14	AB3170921	Stop, Door	1	
15	AB3170340	Hinge, .188" x 4" x 4"	5	
16	AB3171160	Assembly, Grease Bank	1	
17	AB3172698	Brace, Hand Pump and Hopper	1	
18	RC950321	Handle, 5/16-18 Load Rated Pull	2	
19	RC950076	Latch, Lever	6	
20	RC950592	Latch, Rubber Draw	2	
21	RC950607	Latch, Snap-Down Draw	2	
22	RC902772	Bumper, 7/16 x 3/16 Push-In Rubber	9	
23	RC900452	Screw, #8-32 x 1/2 CZ Ph Pan Hd	2	
24	RC901817	Nut, #8-32 YZ Nylock	2	
25	RC902738	Screw, #10-24 x 5/8 CZ Ph Pan Hd	6	
26	RC900667	Washer, #10 SAE YZ Flat	8	
27	RC902420	Nut, #10-24 YZ Nylock	6	
28	RC900046	Bolt, 1/4-20 x 1-3/4 Gr 5 YZ Hex	2	
29	RC902696	Washer, 1/4 SAE YZ Hard Flat	4	
30	RC900575	Nut, 1/4-20 YZ Nylock	2	

7.1 – Shields – Continued

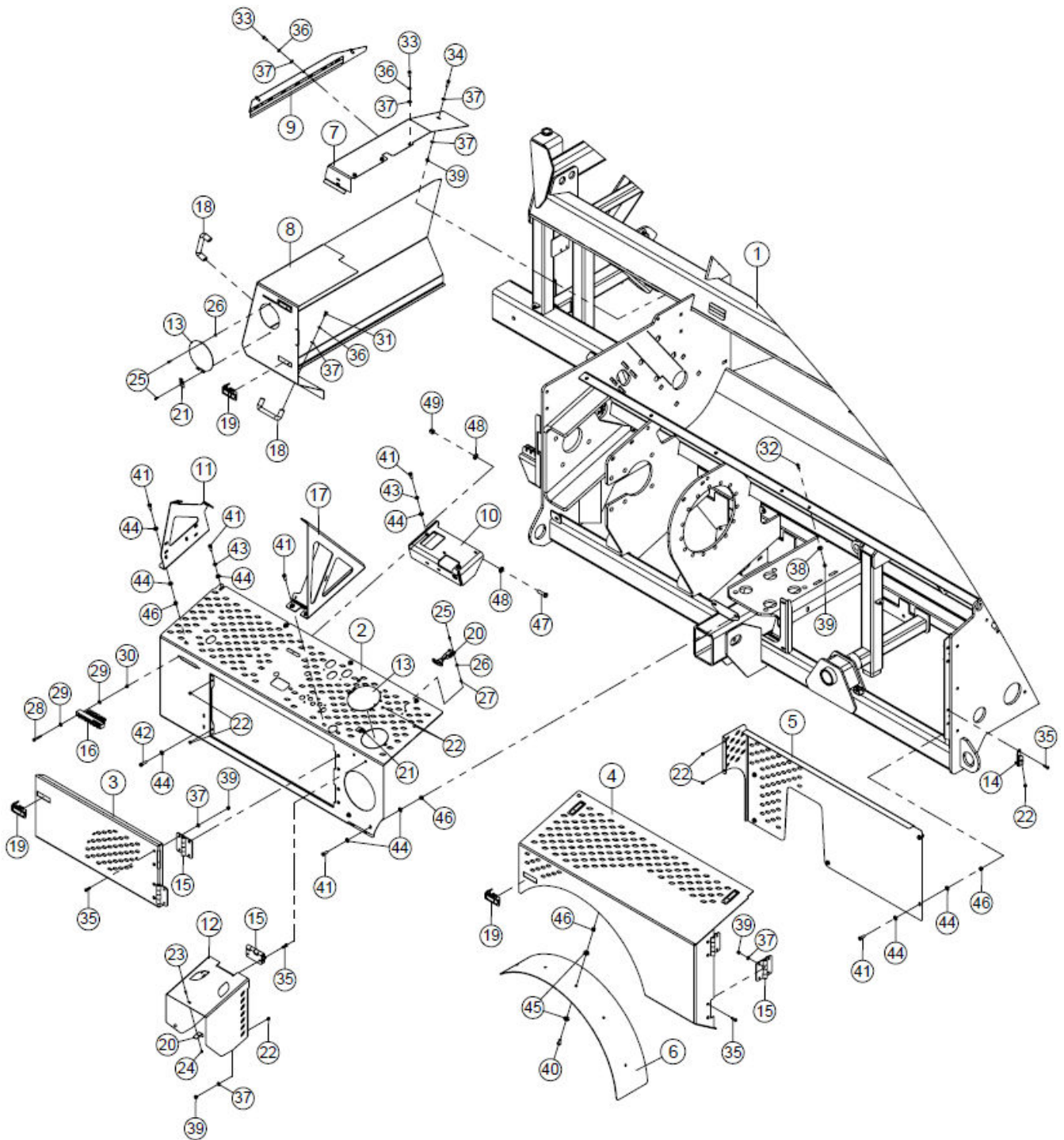

7.1 – Shields - Continued

Key	Part Number	Description	Qty	Comments
31	RC900085	Bolt, 5/16-18 x 5/8 Gr 5 YZ Hex	4	
32	RC902998	Screw, 5/16-18 x 3/4 Gr 8 CZ SH Cap	1	
33	RC900084	Bolt, 5/16-18 x 3/4 Gr 5 YZ Hex	6	
34	RC900063	Bolt, 5/16-18 x 1 Gr 5 YZ Hex	1	
35	RC901632	Screw, 5/16-18 x 1 CZ BH Socket	20	
36	RC900726	Washer, 5/16 YZ Lock	10	
37	RC902162	Washer, 5/16 SAE YZ Hard Flat	32	
38	RC902698	Washer, 5/16 USS YZ Hard Flat	1	
39	RC900579	Nut, 5/16-18 YZ Nylock	22	
40	RC902198	Screw, 3/8-16 x 1 CZ BH Socket	5	
41	RC900088	Bolt, 3/8-16 x 1 Gr 5 YZ Hex	19	
42	RC900091	Bolt, 3/8-16 x 1-1/4 Gr 5 YZ Hex	1	
43	RC900728	Washer, 3/8 YZ Lock	6	
44	RC900677	Washer, 3/8 SAE YZ Hard Flat	34	
45	RC902699	Washer, 3/8 USS YZ Hard Flat	10	
46	RC900583	Nut, 3/8-16 YZ Nylock	19	
47	RC900136	Bolt, 1/2-13 x 1 3/4 Gr 5 YZ Hex	2	
48	RC900691	Washer, 1/2 SAE YZ Hard Flat	4	
49	RC900588	Nut, 1/2-13 YZ Nylock	2	

7.2 – Storage Compartment

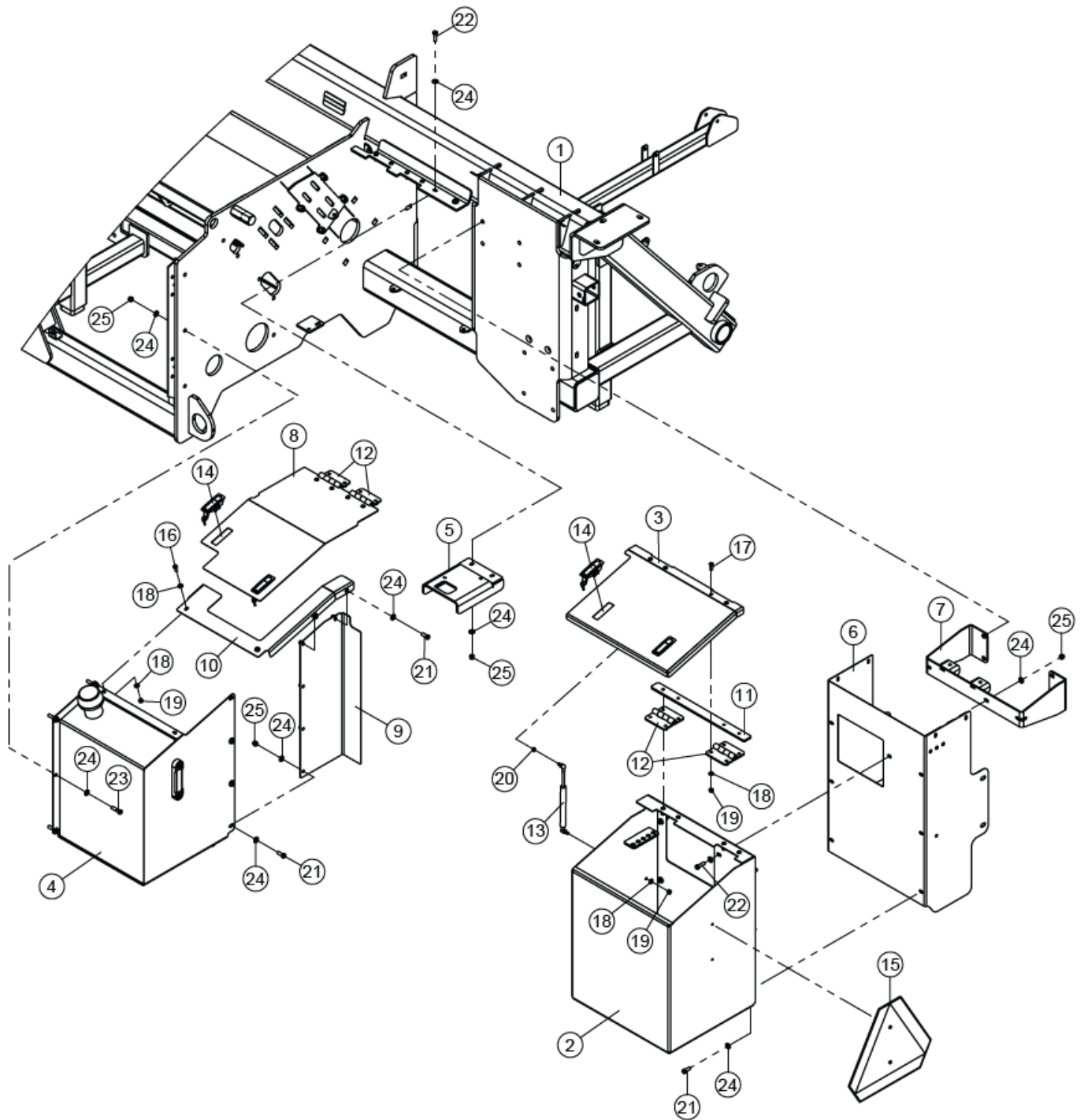

7.2 – Storage Compartment

Key	Part Number	Description	Qty	Comments
1	AB3171358	Frame, T8088 Main	1	
2	AB3171425	Compartment, T8088 Storage	1	
3	AB3171431	Cover, T8088 Storage	1	
4	AB3170199	Assembly, Hydraulic Tank	1	See breakdown on Parts Page 9.3
5	AB3171694	Bracket, T8088 Valve	1	
6	AB3171401	Cover, Lower Anchor Cyl	1	
7	AB3171889	Bracket, Spring Tension	1	
8	AB3171414	Cover, Access	1	
9	AB3171916	Filler, Tank	1	
10	AB3171914	Filler, Tank Upper	1	
11	AB3171427	Spacer, Hinge	1	S/N up to 401098
12	AB3170340	Hinge, .188" x 4" x 4"	4	
13	RC950534	Gas Strut, 12.2" Extended Length 60 lb	1	
14	RC950076	Latch, Lever	4	
15	RC902596	Sign, Plastic SMV	1	
16	RC900084	Bolt, 5/16-18 x 3/4 Gr 5 YZ Hex	2	
17	RC901632	Screw, 5/16-18 x 1 CZ BH Socket	16	
18	RC902162	Washer, 5/16 SAE YZ Hard Flat	21	
19	RC900579	Nut, 5/16-18 YZ Nylock	19	
20	RC902085	Nut, 5/16-18 YZ Nylock Jam	1	
21	RC900088	Bolt, 3/8-16 x 1 Gr 5 YZ Hex	9	
22	RC900091	Bolt, 3/8-16 x 1-1/4 Gr 5 YZ Hex	5	
23	RC900093	Bolt, 3/8-16 x 1-1/2 Gr 5 YZ Hex	8	
24	RC900677	Washer, 3/8 SAE YZ Hard Flat	44	
25	RC900583	Nut, 3/8-16 YZ Nylock	22	

8.1 – Transport

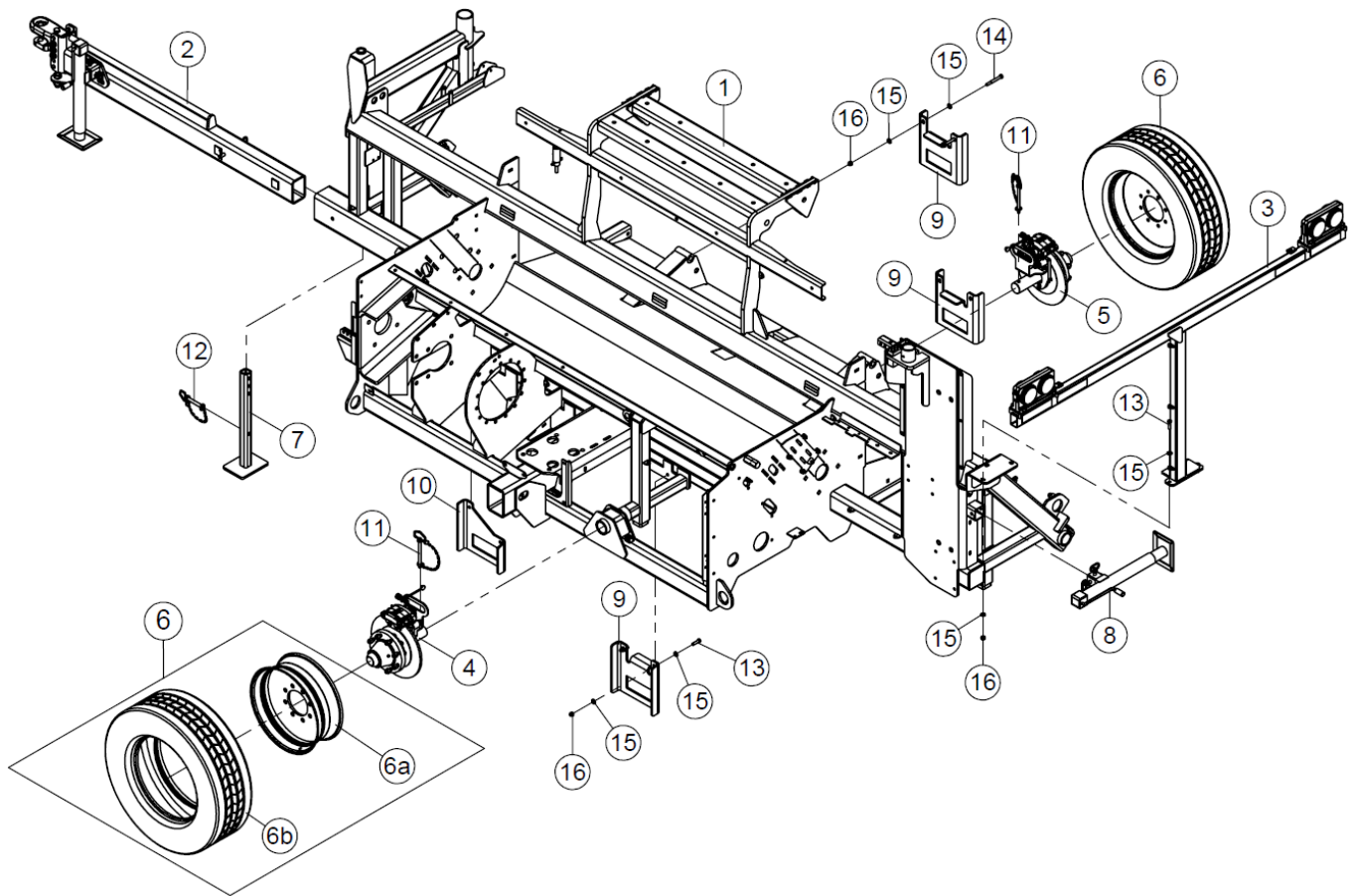

8.1 – Transport

Key	Part Number	Description	Qty	Comments
1	AB3171358	Frame, T8088 Main	1	
2	AB3172129	Assembly, T8088 Hitch	1	S/N 401096 - X See breakdown on Parts Page 8.4
	AB3172133	Assembly, 8088 Hitch	1	S/N up to 401095
3	AB3170498	Assembly, Light Bar	1	See breakdown on Parts Page 8.5
4	AB3171628	Assembly, LH Spindle	1	See breakdown on Parts Page 8.2 & 8.3
5	AB3171866	Assembly, RH Spindle	1	See breakdown on Parts Page 8.2 & 8.3
6	AB3171675	Assembly, Wheel & Tire	2	
6a	AB3171630	Rim, 19.5 x 6.75	1	
6b	RC950709	Tire, T8088	1	
7	AB3170623	Stand, Jack	1	
8	AA1501398	Jack, Manual 8000# 2.5 Sq Mnt	1	
9	AB3171958	Bracket, Shipping	3	For shipping use only
10	AB3171964	Bracket, Shipping	1	For shipping use only
11	RC902788	Pin, 1/2 x 5-3/4 YZ Hitch	2	
12	RC902455	Pin, 5/8 x 4 YZ Hitch	1	
13	RC900136	Bolt, 1/2-13 x 1 3/4 Gr 5 YZ Hex	7	
14	RC901372	Bolt, 1/2-13 x 4-1/4 Gr 8 YZ Hex	4	
15	RC900691	Washer, 1/2 SAE YZ Hard Flat	22	
16	RC900588	Nut, 1/2-13 YZ Nylock	11	

8.2 – Brake System - S/N up to 401098

Key	Part Number	Description	Qty	Comments
1	AB3171628	Assembly, LH Spindle	1	
1a	AB3172081	Caliper, Brake	1	See breakdown on Parts Page 10.6
1b	RC950669	Assembly, 8 on 8 Spindle	1	See breakdown on Parts Page 10.7
1c	AB3172073	Disc, Rotor	1	
1d	AB3172075	Bracket, Caliper Mount	1	
1e	AB3171616	Clamp, Caliper Mount	2	
1f	AB3172080	Handle, Spindle	1	
1g	RC700628	Reducer, -04 MORB -06 FORB Straight	1	
1h	RC700395	Union, -06 MORB 90°	1	
1j	RC703174	Valve, -06 MORB -06 FORB Inline Check	1	
1k	RC703175	Breather, -06 MORB Brass	1	
1m	RC703160	Cap, 1/4" Body Dust	1	
1n	RC702811	Coupler, Female	1	
1p	RC702812	Coupler, Male	1	
1q	RC900088	Bolt, 3/8-16 x 1 Gr 5 YZ Hex	2	
1r	RC900093	Bolt, 3/8-16 x 1-1/2 Gr 5 YZ Hex	4	
1s	RC902706	Screw, 3/8-16 x 2 BO Socket Head Cap	2	
1t	RC900728	Washer, 3/8 YZ Lock	6	
1u	RC900677	Washer, 3/8 SAE YZ Hard Flat	6	
1w	RC902897	Screw, 1/2-20 x 1-1/2 CZ Flat Head Socket	4	
2	AB3171866	Assembly, RH Spindle	1	
3	AA0900040	Pump, 17 CI 2000 PSI Hand	1	See breakdown on Parts Page 10.5
4	RC950760	Accumulator, 1250 psi Pre-Charged x 9.8 CUI	2	
5	AB3171266	Assembly, Hydraulic Hose	1	
6	AB3171268	Assembly, Hydraulic Hose	1	
7	AB3171270	Assembly, Hydraulic Hose	1	
8	AB3171272	Assembly, Hydraulic Hose	1	

8.2 – Brake System - S/N up to 401098 - Continued

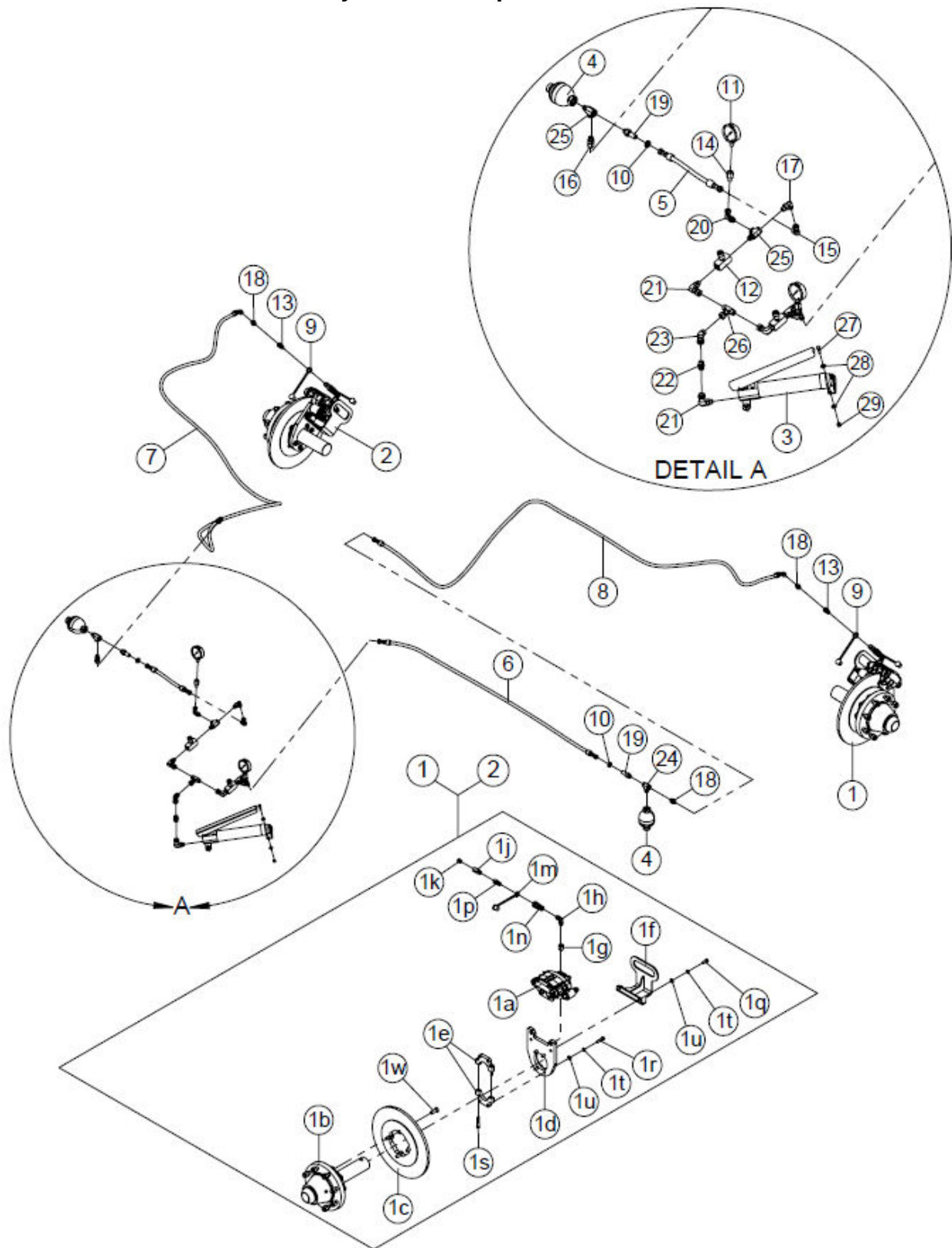

8.2 – Brake System - S/N up to 401098 - Continued

Key	Part Number	Description	Qty	Comments
9	RC703160	Cap, 1/4" Body Dust	2	
10	RC700010	Nut, 9/16-18 Bulkhead Lock	2	
11	AA1500142	Gauge, 2000 PSI SM Liquid Sill	2	
12	RC703141	Valve, -06 ORB 5000 PSI Steel Needle	2	
13	RC702812	Coupler, Male	2	
14	RC701096	Fitting, 1/4 MPT x 1/4 FPT Expander	2	
15	RC700179	Elbow, -04 MORFS -04 FORFS Swivel 90°	2	
16	RC700877	Elbow, -04 MORFS -06 MORB 45°	1	
17	RC700115	Elbow, -04 MORFS -06 MORB 90°	2	
18	RC700074	Adapter, -04 MORFS -06 MORB Straight	3	
19	RC701016	Adapter, -04 MORFS -06 MORB Straight Bulkhead	2	
20	RC701511	Elbow, -06 MORB -04 FPT Swivel 90°	2	
21	RC700172	Adapter, -06 FORFS x -06 MORB 90°	3	
22	RC700028	Adapter, -06 MORFS -06 MORFS Straight	1	
23	RC700195	Elbow, -06 FORFS -06 MORFS 45°	1	
24	RC702611	Tee, -06 MORB Branch	1	
25	RC703073	Tee, -06 MORB Run	3	
26	RC700164	Tee, -06 ORFS Outlet	1	
27	RC900042	Bolt, 1/4-20 x 1 Gr 5 YZ Hex	4	
28	RC902696	Washer, 1/4 SAE YZ Hard Flat	8	
29	RC900575	Nut, 1/4-20 YZ Nylock	4	
	AB3171087	Oil, Hydraulic Jack - 1.5 qt.	1	Brake system oil

8.3 – Brake System - S/N 401099 – X

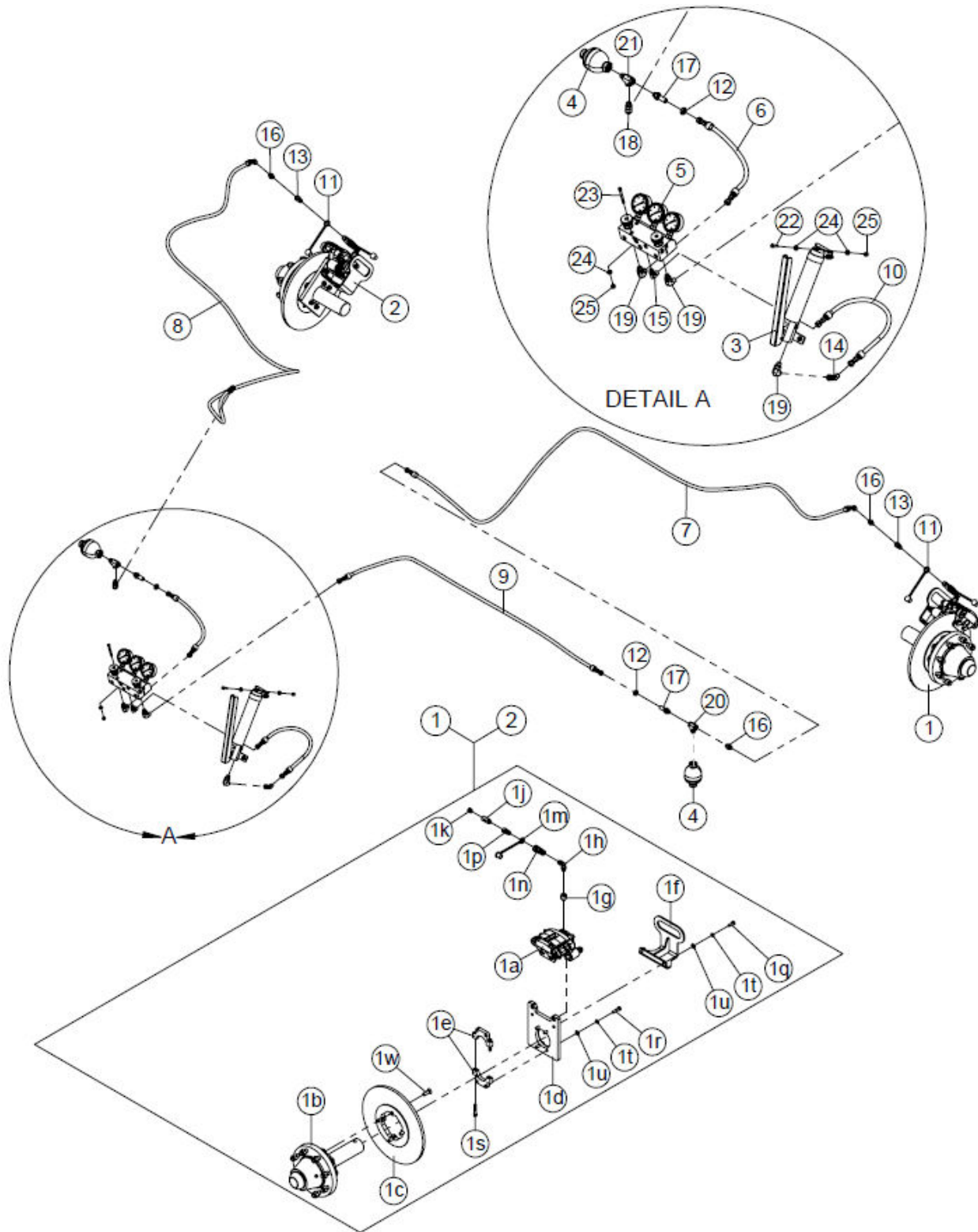

8.3 – Brake System - S/N 401099 – X

Key	Part Number	Description	Qty	Comments
1	AB3171628	Assembly, LH Spindle	1	
1a	AB3172081	Caliper, Brake	1	See breakdown on Parts Page 10.6
1b	RC950669	Assembly, 8 on 8 Spindle	1	See breakdown on Parts Page 10.7
1c	AB3172073	Disc, Rotor	1	
1d	AB3172075	Bracket, Caliper Mount	1	
1e	AB3171616	Clamp, Caliper Mount	2	
1f	AB3172080	Handle, Spindle	1	
1g	RC700628	Reducer, -04 MORB -06 FORB Straight	1	
1h	RC700395	Union, -06 MORB 90°	1	
1j	RC703174	Valve, -06 MORB -06 FORB Inline Check	1	
1k	RC703175	Breather, -06 MORB Brass	1	
1m	RC703160	Cap, 1/4" Body Dust	1	
1n	RC702811	Coupler, Female	1	
1p	RC702812	Coupler, Male	1	
1q	RC900088	Bolt, 3/8-16 x 1 Gr 5 YZ Hex	2	
1r	RC900093	Bolt, 3/8-16 x 1-1/2 Gr 5 YZ Hex	4	
1s	RC902706	Screw, 3/8-16 x 2 BO Socket Head Cap	2	
1t	RC900728	Washer, 3/8 YZ Lock	6	
1u	RC900677	Washer, 3/8 SAE YZ Hard Flat	6	
1w	RC902897	Screw, 1/2-20 x 1-1/2 CZ Flat Head Socket	4	
2	AB3171866	Assembly, RH Spindle	1	
3	AA0900040	Pump, 17 CI 2000 PSI Hand	1	See breakdown on Parts Page 10.5
4	RC950760	Accumulator, 1250 psi Pre-Charged x 9.8 CUI	2	
5	AB3172575	Assembly, Brake Hand Pump Gauge Station	1	See breakdown on Parts Page 10.10

8.3 – Brake System - S/N 401099 – X - Continued

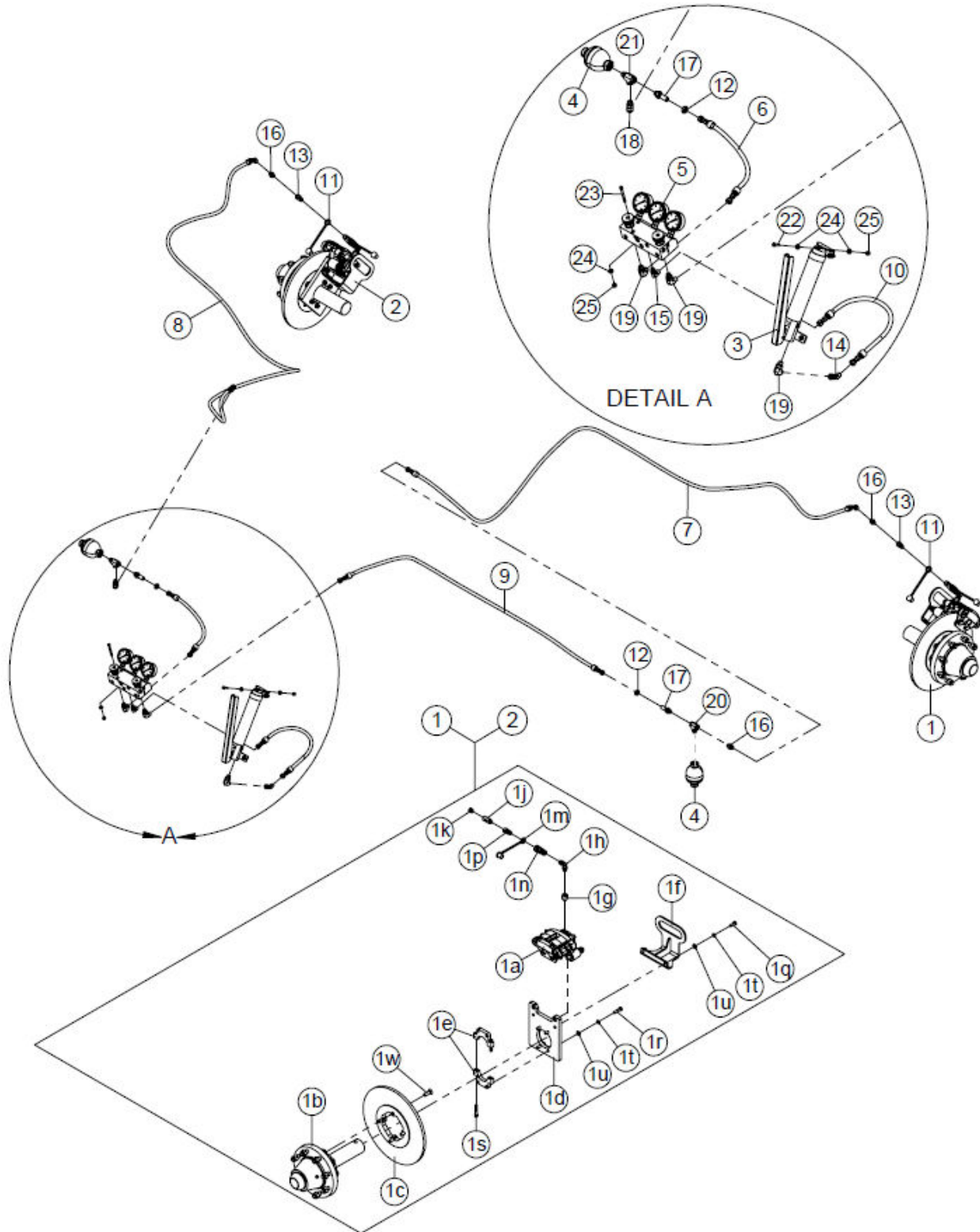

8.3 – Brake System - S/N 401099 – X - Continued

Key	Part Number	Description	Qty	Comments
6	AB3171266	Assembly, Hydraulic Hose	1	
7	AB3171272	Assembly, Hydraulic Hose	1	
8	AB3171270	Assembly, Hydraulic Hose	1	
9	AB3171268	Assembly, Hydraulic Hose	1	
10	AB3172701	Assembly, Brake Jumper Hose	1	
11	RC703160	Cap, 1/4" Body Dust	2	
12	RC700010	Nut, 9/16-18 Bulkhead Lock	2	
13	RC702812	Coupler, Male	2	
14	RC700194	Elbow, -04 FORFS -04 MORFS 45°	1	
15	RC700114	Elbow, -04 MORFS -04 MORB 90°	1	
16	RC700074	Adapter, -04 MORFS -06 MORB Straight	3	
17	RC701016	Adapter, -04 MORFS -06 MORB Straight Blkhd	2	
18	RC700877	Elbow, -04 MORFS -06 MORB 45°	1	
19	RC700115	Elbow, -04 MORFS -06 MORB 90°	3	
20	RC702611	Tee, -06 MORB Branch	1	
21	RC703073	Tee, -06 MORB Run	1	
22	RC900042	Bolt, 1/4-20 x 1 Gr 5 YZ Hex	4	
23	RC902981	Screw, 1/4-20 x 2-1/2 CZ Socket Head Cap	3	
24	RC902696	Washer, 1/4 SAE YZ Hard Flat	11	
25	RC900575	Nut, 1/4-20 YZ Nylock	7	
	AB3171087	Oil, Hydraulic Jack - 1.5 qt.	1	Brake system oil

8.4 – Hitch

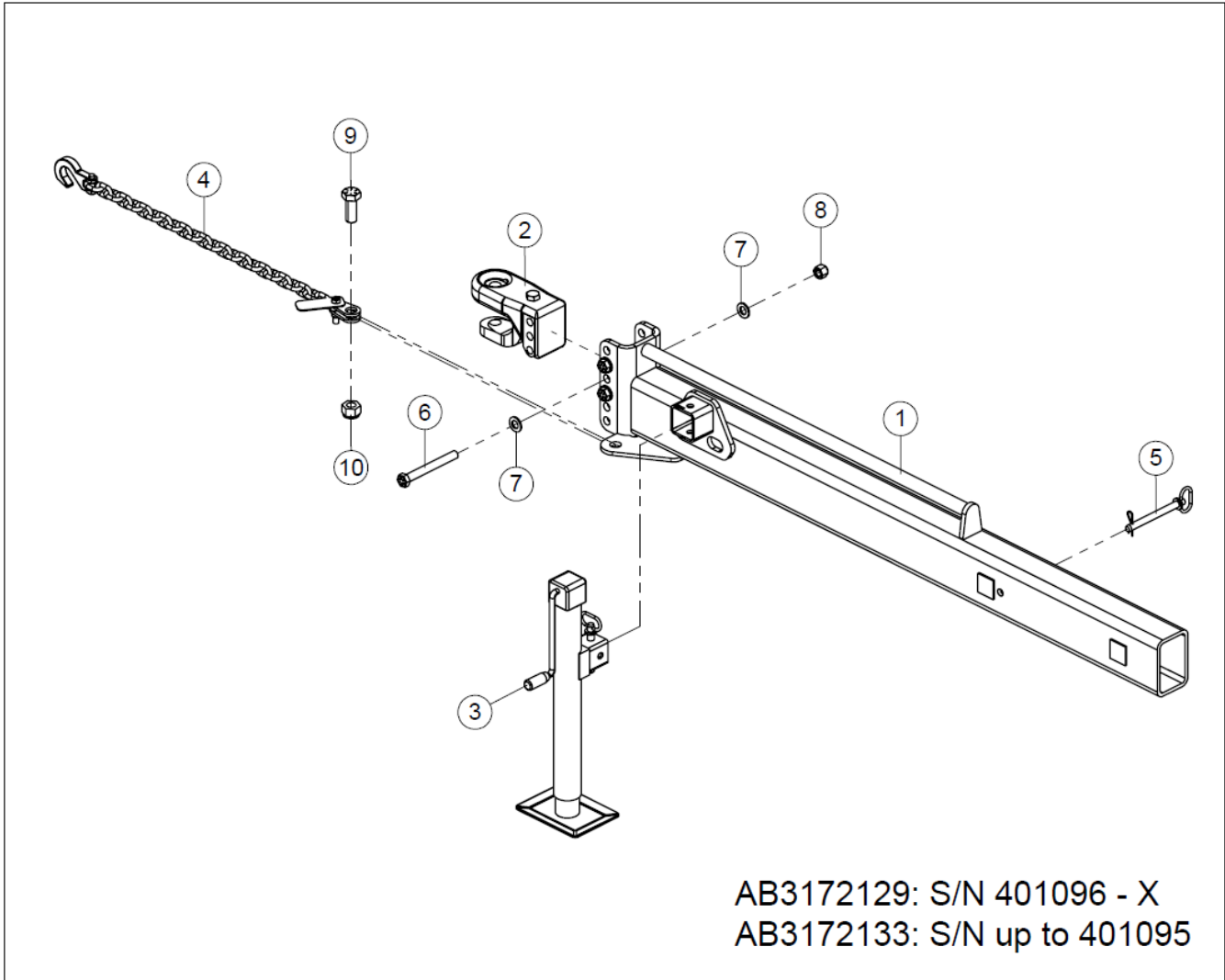

8.4 – Hitch

Key	Part Number	Description	Qty	Comments
1	AB3172128	Hitch, T8088	1	S/N 401096 - X
	AB3172132	Hitch, 8088	1	S/N up to 401095
2	RC950722	Hitch, 3 Hole Category 3 Drawbar w/ Clevis	1	
3	AA1501398	Jack, Manual 8000# 2.5 Sq Mnt	1	
4	RC950617	Chain, 3/8 Grade 70 x 31" Safety	1	
5	RC900909	Pin, 5/8 x 5-3/4 YZ Hitch	1	
6	RC900322	Bolt, 3/4-10 x 6-1/2 Gr 8 YZ Hex	3	
7	RC902416	Washer, 3/4 SAE YZ Hard Flat	6	
8	RC900597	Nut, 3/4-10 YZ Nylock	3	
9	RC901599	Bolt, 1-8 x 2-1/2 Gr 8 YZ Hex	1	
10	RC900601	Nut, 1-8 YZ Nylock	1	

8.5 – Light Bar

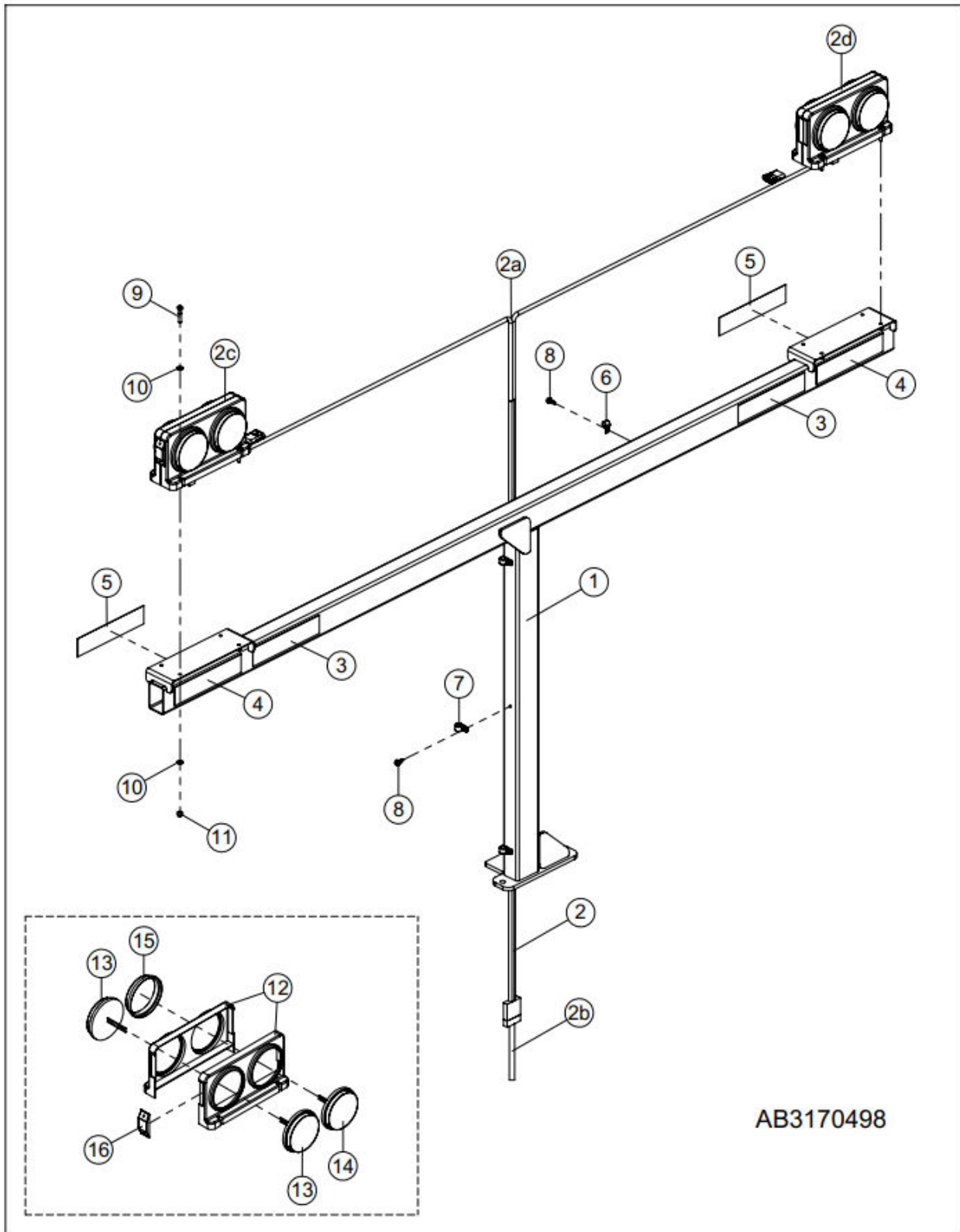

AB3170498

8.5 – Light Bar

Key	Part Number	Description	Qty	Comments
1	AB3170494	Bar, Light	1	
2	AB3170926	Kit, Lights w/Harness	1	
2a	AB3170925	Harness, Light	1	
2b	AA0900460	Harness, Light 6000 Series	1	
2c	RC750591	Indicator, Left Stop Turn Tail LED Warning	1	
2d	RC750592	Indicator, Right Stop Turn Tail LED Warning	1	
3	RC901941	Decal, Fluorescent Orange 2 x 9 Marker	2	
4	RC901940	Reflector, Red 2 x 9	2	
5	RC901939	Reflector, Yellow 2 x 9	2	
6	RC902782	P-Clamp, 3/8 Cushion	8	
7	RC902783	P-Clamp, 1/2 Cushion	3	
8	RC901773	Screw, 1/4-14 x 3/4 CZ Self Drilling	11	
9	RC900045	Bolt, 1/4-20 x 1-1/2 Gr5 YZ Hex	8	
10	RC902696	Washer, 1/4 SAE YZ Hard Flat	16	
11	RC900575	Nut, 1/4-20 YZ Nylock	8	
12	RC750596	Frame, Double Light Half	2	
13	RC750593	Light, Round Amber LED	2	
14	RC750594	Light, Round Red LED	1	
15	RC750595	Blank, Lens Filler	1	
16	RC750597	Light, Amber Clearance	1	

8.6 – Hydraulic Machine Lift

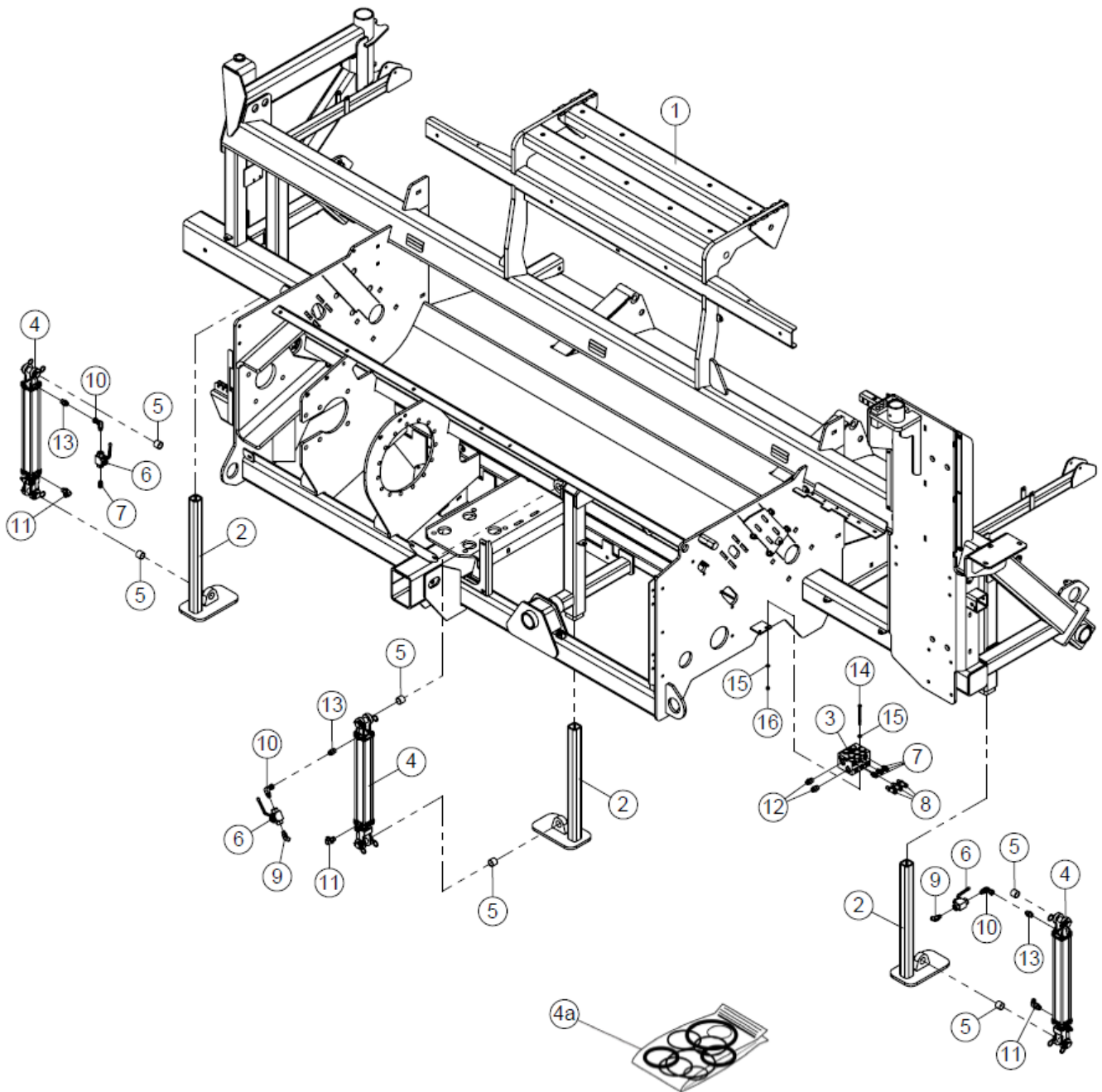

8.6 – Hydraulic Machine Lift

Key	Part Number	Description	Qty	Comments
1	AB3171358	Frame, T8088 Main	1	
2	AB3171908	Pad, Lift	3	
3	RC950671	Assembly, 3-Way Flow Divider	1	See breakdown on Parts Page 10.9
4	RC950672	Cylinder, 2" x 16" Tie Rod	3	
4a	RC950639	Kit, Cylinder Seal	1	
5	RC950618	Bearing, 1" ID x 1" High Load Bronze Sleeve	6	
6	RC700389	Valve, -06 FORB Ball	3	
7	RC700077	Adapter, -06 MORFS -06 MORB Straight	4	
8	RC700107	Adapter, -06 MORFS x -06 MORB Straight Long	3	
9	RC700880	Elbow, -06 MORFS -06 MORB 45°	2	
10	RC700172	Adapter, -06 FORFS x -06 MORB 90°	3	
11	RC700119	Elbow, -06 MORFS -08 MORB 90°	3	
12	RC700078	Adapter, -06 MORFS -08 MORB Straight	2	
13	RC703170	Adapter, -06 MORFS -08 MORB x .062" Orifice	3	
14	RC900076	Bolt, 5/16-18 x 4 Gr 5 YZ Hex	2	
15	RC902162	Washer, 5/16 SAE YZ Hard Flat	4	
16	RC900579	Nut, 5/16-18 YZ Nylock	2	

8.7 – Machine Decals

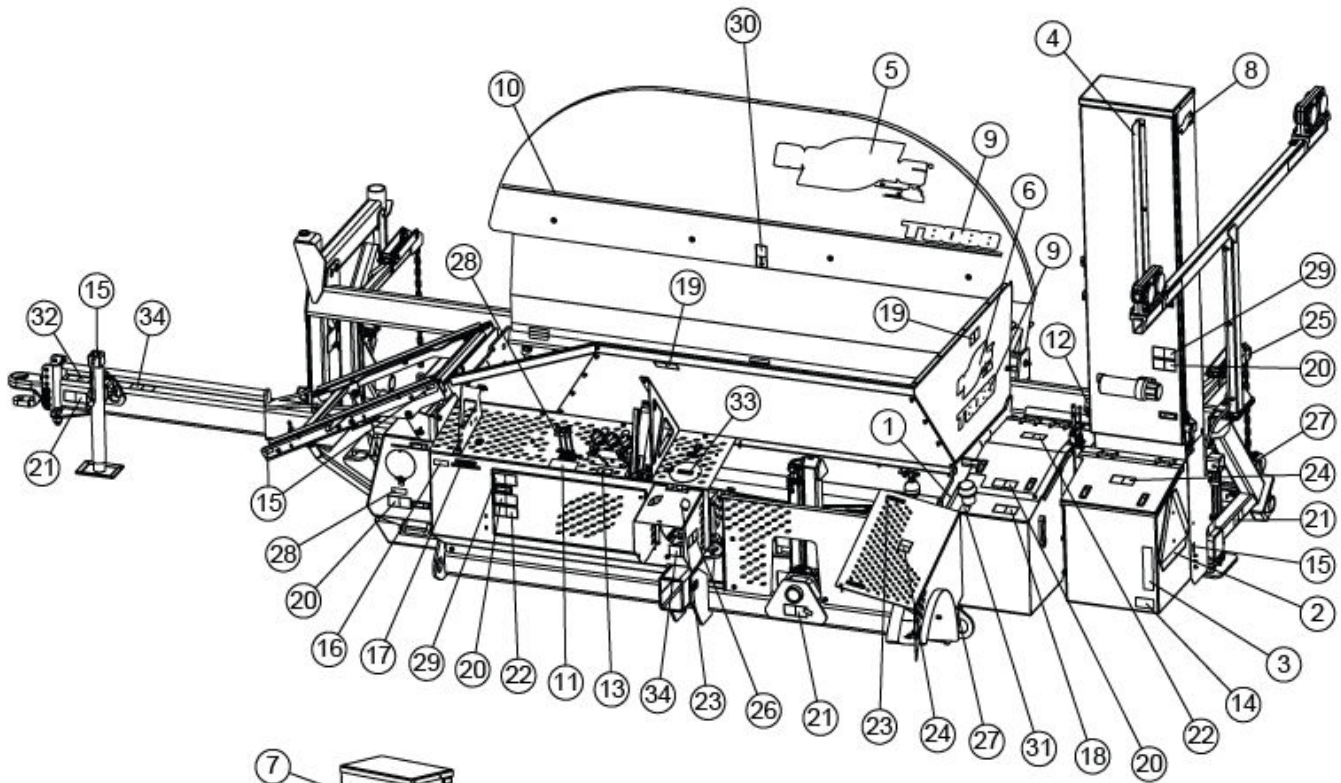

AB3171677 - T8088 Decal Kit

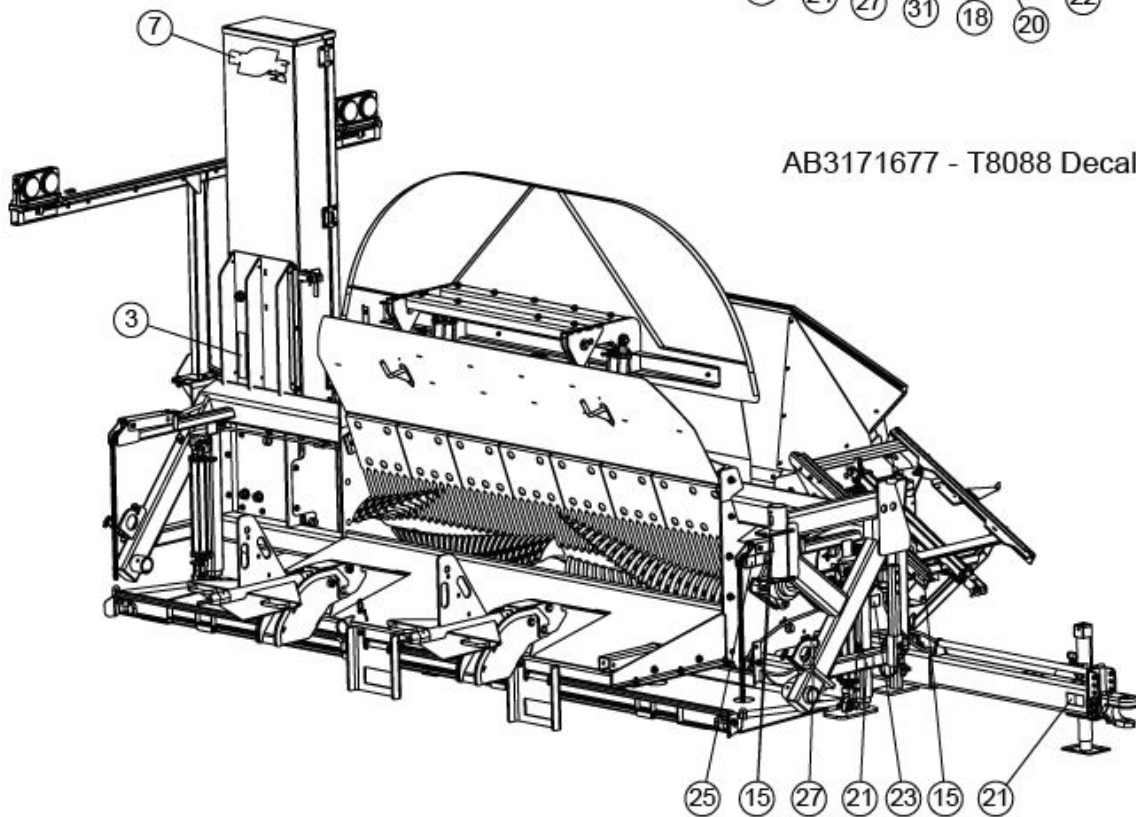

8.7 – Machine Decals

Key	Part Number	Description	Qty	Comments
1	AB3170684	Tag, AB317 Serial Number	1	Not included in kit
2	RC902596	Sign, Plastic SMV	1	Not included in kit
3	RC901939	Reflector, Yellow 2 x 9	2	Not included in kit
4	AB3171676	Decal, Anchor Position	1	
5	AA0701571	Decal, 12" x 32" AgBag by RCI Logo	1	
6	AA0901563	Decal, 7" x 19" AgBag by RCI Logo	1	
7	AA0800935	Decal, 5.9" x 16" AgBag by RCI Logo	1	
8	AA0800937	Decal, 2.7" x 7.4" AgBag by RCI Logo	1	
9	AB3171760	Decal, T8088 Model Number	2	
10	AB3171759	Decal, 104" Double Line	1	
11	AB3171761	Decal, 3 Bank Hydraulic Controls	1	
12	AB3171162	Decal, Cleanout Door and Machine Lift Controls	1	
13	AB3171739	Decal, Ag-Bag Manuals QR Code	1	
14	RC901937	Decal, American Flag	1	
15	RC901933	Decal, Grease	14	
16	RC902796	Decal, Grease Every 2 Hours	1	
17	AB3171163	Decal, Horizontal Grease Bank	1	
18	RC902822	Decal, Hot Surface Warning	1	
19	RC902036	Decal, ISO Auger Entanglement	2	
20	RC901932	Decal, ISO Entanglement Hazard	5	
21	RC902793	Decal, ISO Foot Crush Hazard	5	
22	RC901935	Decal, ISO High Pressure Fluid Hazard	2	
23	RC901926	Decal, ISO Keep Safe Distance	6	
24	RC902794	Decal, ISO No Step Hazard	2	
25	RC902035	Decal, ISO Pinch Point Hazard Horizontal	2	
26	RC902791	Decal, ISO PTO Entanglement	2	
27	RC901930	Decal, ISO Tiedown	4	
28	RC902797	Decal, Oil Every 2 Hours	2	
29	RC901934	Decal, Read OPM	2	
30	RC902823	Decal, Read OPM Arrow White	1	
31	RC901959	Decal, Universal Trans Oil	1	
32	RC902821	Decal, 25 MPH Speed Limit	1	
33	RC902842	Decal, Mobil SHC™ Gear 220 Oil	1	
34	RC902843	Decal, 1000 PTO Warning	2	

8.8 – Conveyor Decals

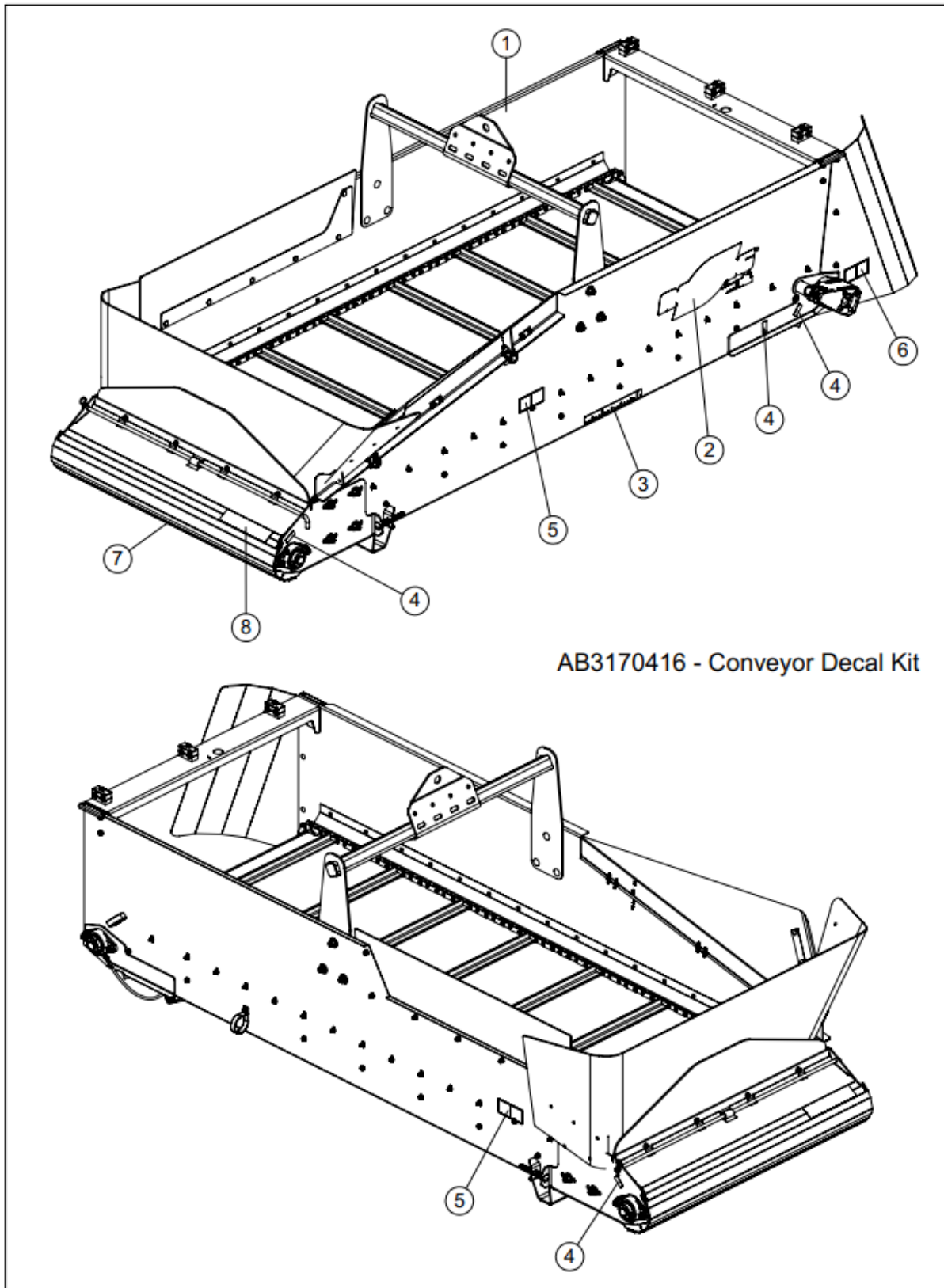

8.8 – Conveyor Decals

Key	Part Number	Description	Qty	Comments
1	AB3170102	Assembly, Wide Single Chain Conveyor	1	
2	AA0901563	Decal, 7" x 19" AgBag by RCI Logo	1	
3	AB3170970	Decal, Conveyor Position	1	
4	RC901933	Decal, Grease	4	
5	RC902792	Decal, ISO Conveyor Entanglement	2	
6	RC901932	Decal, ISO Entanglement Hazard	1	
7	RC901926	Decal, ISO Keep Safe Distance	1	Inside of cleanout door
8	RC901939	Reflector, Yellow 2 x 9	1	Not included in kit

9.1 – RH Control Valve Fittings

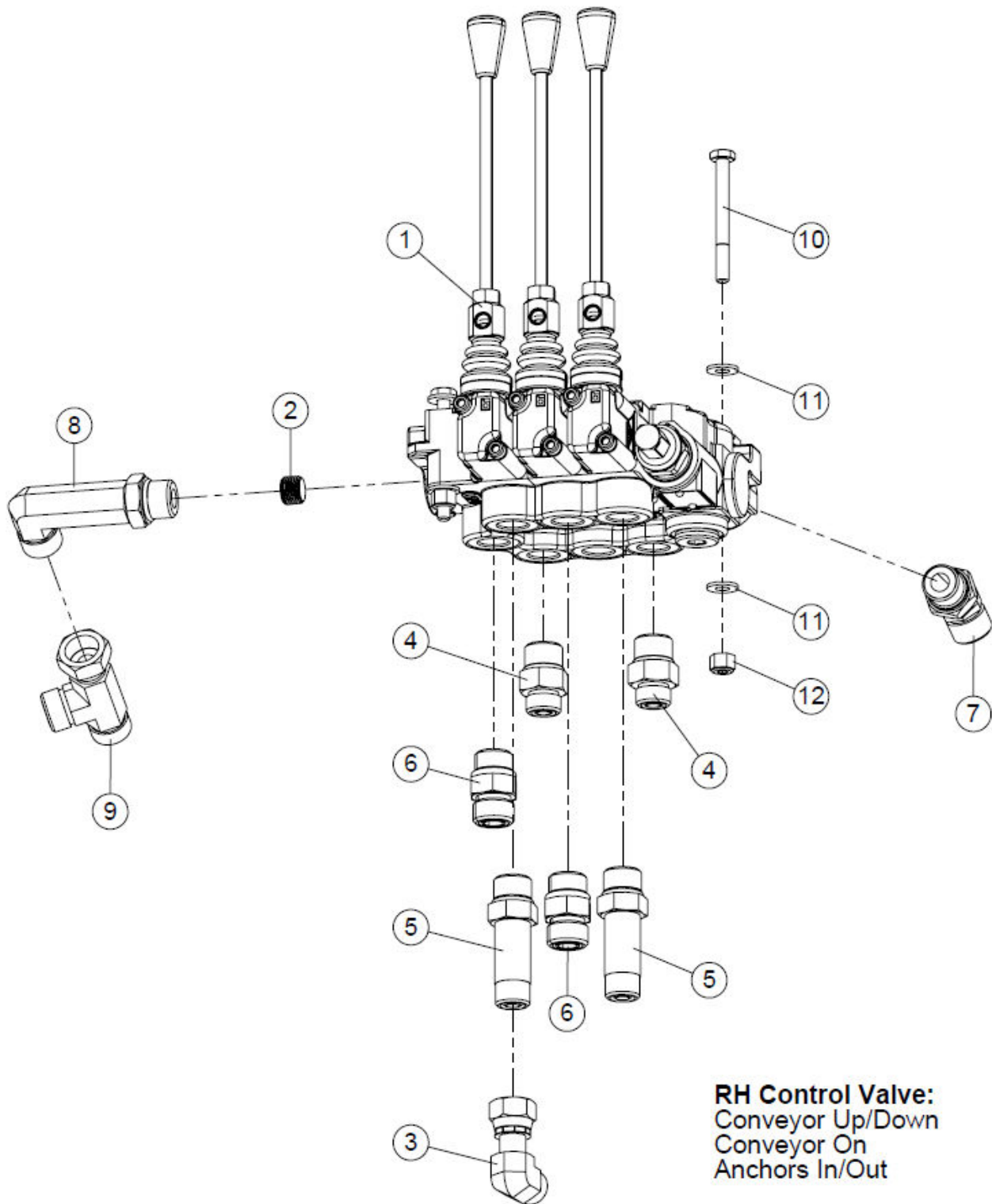

9.1 – RH Control Valve Fittings

Key	Part Number	Description	Qty	Comments
1	AB3171238	Valve, 3-Bank Hand Control	1	See breakdown on Parts Page 10.3
2	RC950728	Plug, Power Beyond	1	
3	RC700181	Elbow, -06 MORFS -06 FORFS Swivel 90°	1	
4	RC700078	Adapter, -06 MORFS -08 MORB Straight	2	
5	RC700108	Adapter, -06 MORFS x -08 MORB Straight Long	2	
6	RC700083	Adapter, -08 MORFS -08 MORB Straight	2	
7	RC700884	Elbow, -08 MORFS -08 MORB 45°	1	
8	RC700309	Elbow, -08 MORFS -08 MORB Long 90°	1	
9	RC700157	Tee, -08 ORFS Run Thru	1	
10	RC900049	Bolt, 1/4-20 x 2-1/2 Gr 5 YZ Hex	2	
11	RC902696	Washer, 1/4 SAE YZ Hard Flat	4	
12	RC900575	Nut, 1/4-20 YZ Nylock	2	

9.2 – LH Control Valve Fittings

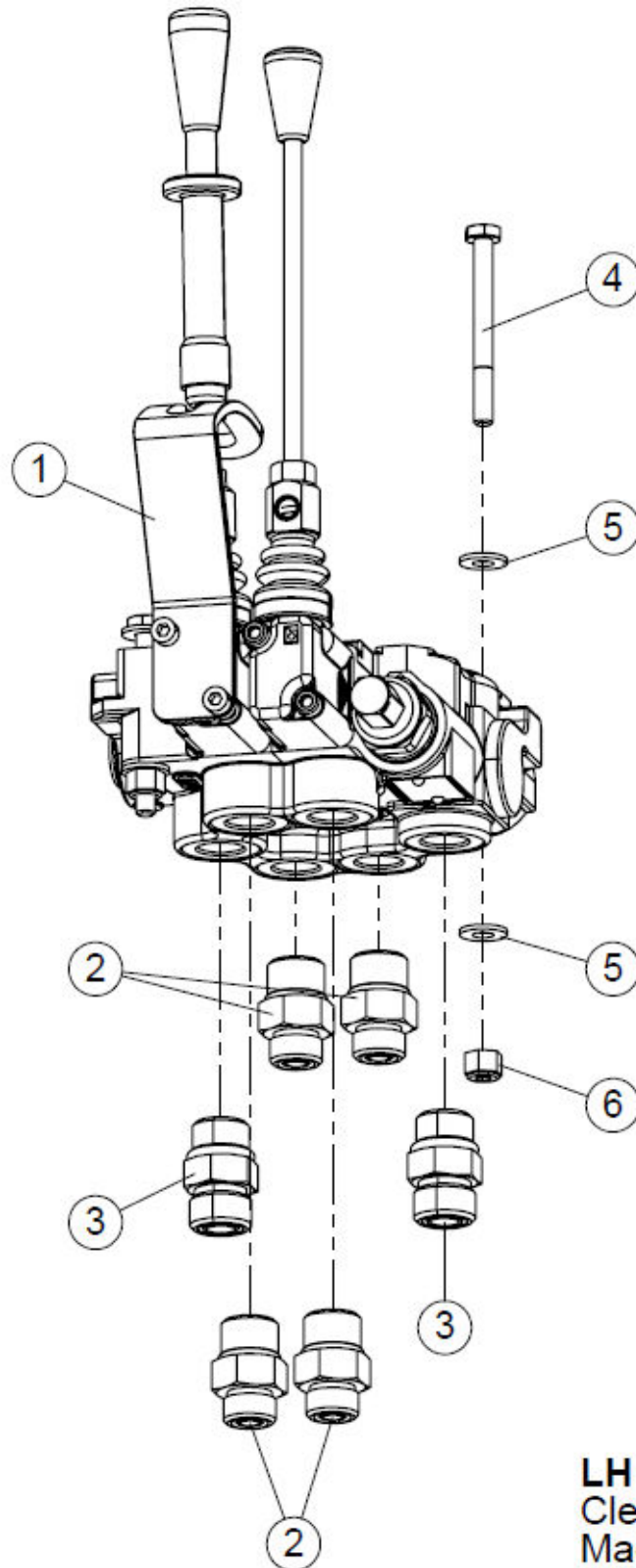

LH Control Valve:
 Cleanout Door In/Out
 Machine Lift Up/Down

9.2 – LH Control Valve Fittings

Key	Part Number	Description	Qty	Comments
1	AB3171168	Valve, 2-Bank Hand Control	1	See breakdown on Parts Page 10.4
2	RC700078	Adapter, -06 MORFS -08 MORB Straight	4	
3	RC700083	Adapter, -08 MORFS -08 MORB Straight	2	
4	RC900049	Bolt, 1/4-20 x 2-1/2 Gr 5 YZ Hex	2	
5	RC902696	Washer, 1/4 SAE YZ Hard Flat	4	
6	RC900575	Nut, 1/4-20 YZ Nylock	2	

9.3 – Hydraulic Tank

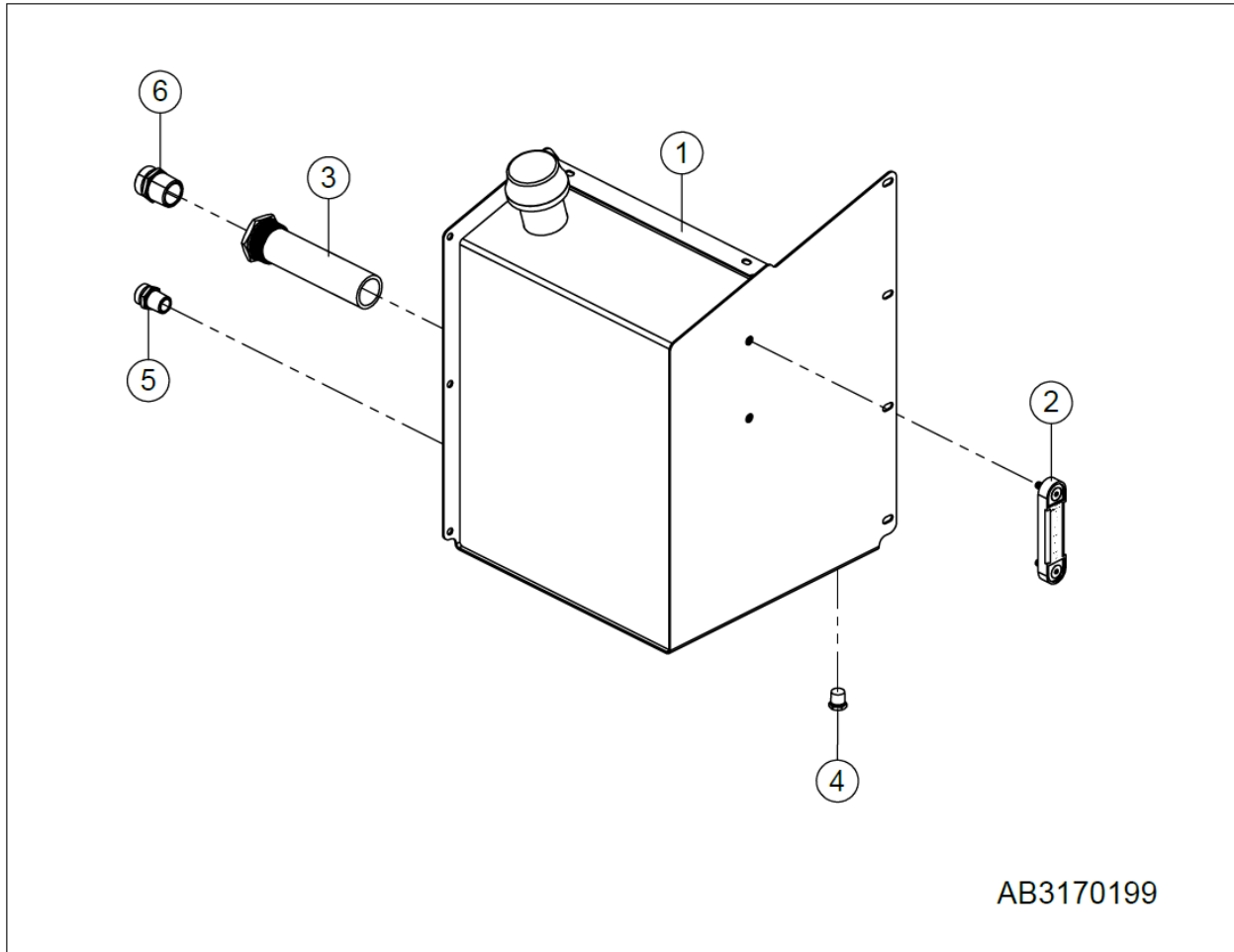

9.3 – Hydraulic Tank

Key	Part Number	Description	Qty	Comments
1	AB3170198	Tank, Hydraulic	1	
2	RC700603	Gauge, Level and Temp	1	
3	RC700605	Strainer, In-Tank	1	
4	RC701310	Plug, -08 External Hex Pipe	1	
5	RC700988	Adapter, -12 MORFS -12 MPT Straight	1	
6	RC700995	Adapter, -20 MORFS -20 MPT Straight	1	
	AB3170927	Oil, Hygard - 22 gal.	1	Hydraulic System Oil

10.1 – Planetary Gearbox

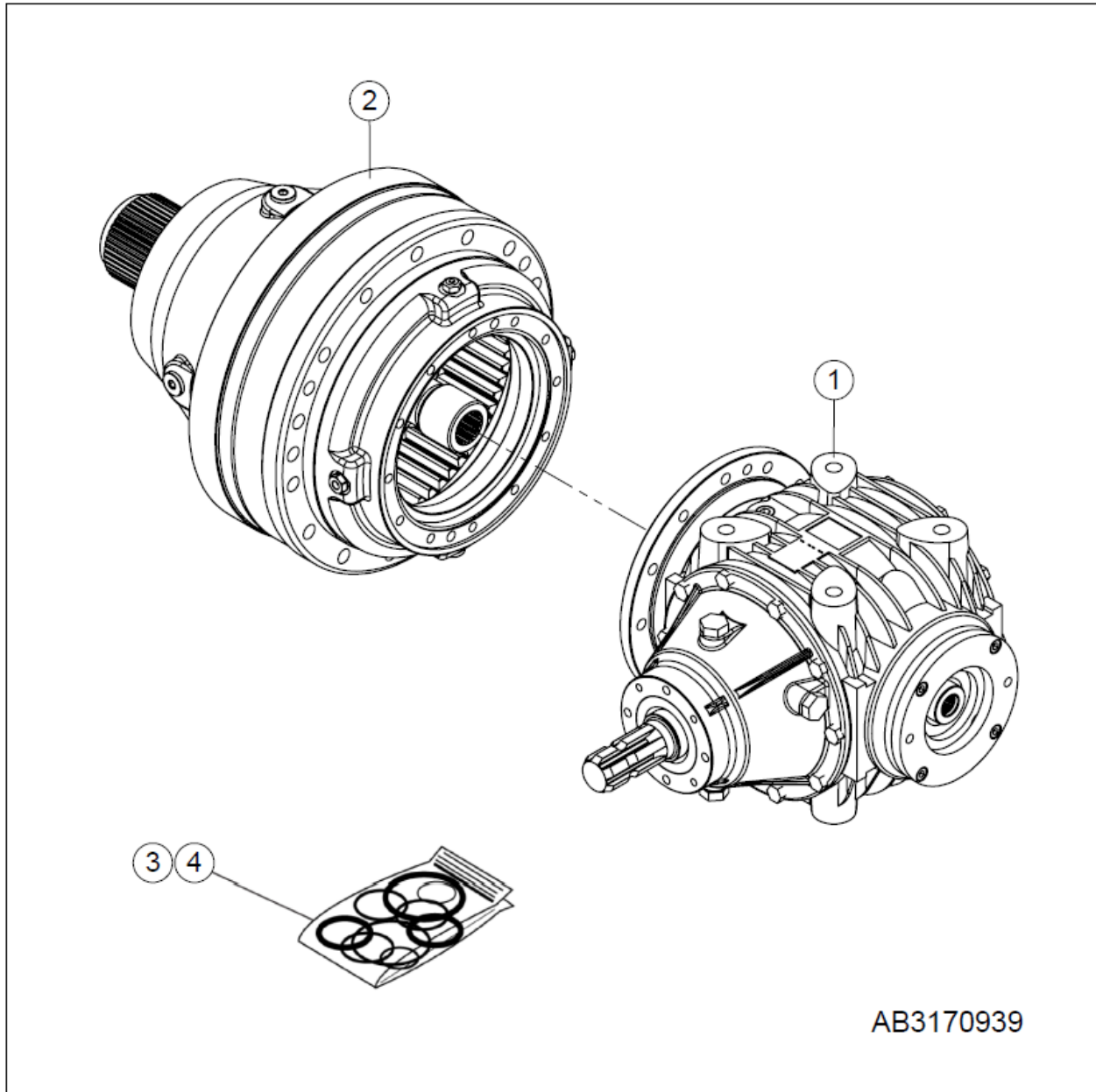

AB3170939

10.1 – Planetary Gearbox

Key	Part Number	Description	Qty	Comments
1	AB3171239	Gearbox, T152 Bevel	1	
2	AB3171240	Planetary, PD 117	1	
3	AB3171241	Kit, Input Seal and Bearing	1	
4	AB3171242	Kit, Output Seal and Bearing	1	
5	AB3171214	Oil, Mobil SHC Gear 220 - 3.9 gal.	1	Oil for Gearbox

10.2 – 1000 PTO

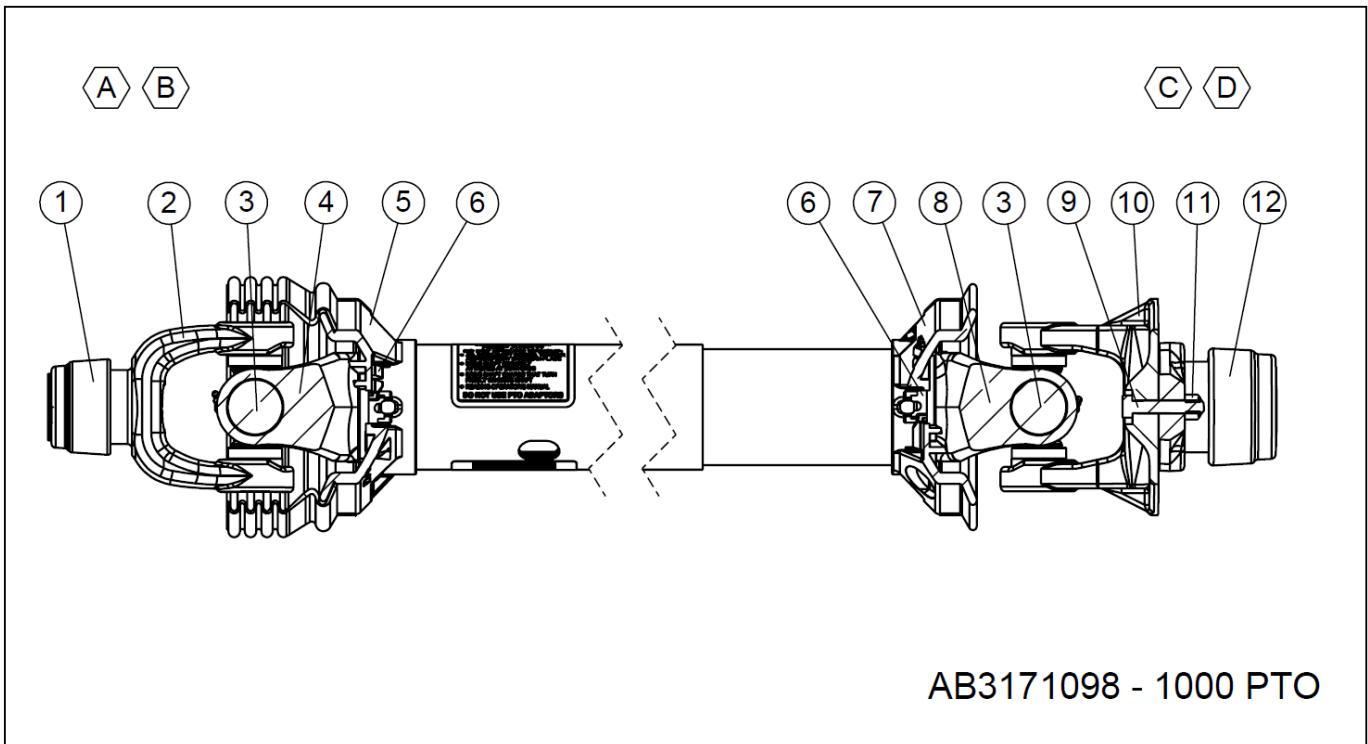

10.2 – 1000 PTO

Key	Part Number	Description	Qty	Comments
A	AB3171217	Half, Guarded Joint & Shaft	1	
B	AB3171218	Half, Joint & Shaft	1	
C	AB3171225	Half, Guarded Joint & Tube	1	
D	AB3171226	Half, Joint & Tube	1	
1	AB3171220	Kit, Auto-Lok Repair	1	
2	AB3171219	Yoke, 55 Slide Lock	1	Small 1000
2	AB3171797	Yoke, Large 1000 (55 Slide Lock)	1	Large 1000; Optional
3	AB3171221	Kit, 55E Cross	2	
4	AB3171222	Yoke & Shaft, 1.69-20 Spline	1	
5	AB3171223	Guard, Outer	1	
6	AB3171224	Kit, Guard Repair	2	
7	AB3172707	Guard, Inner	1	
8	AB3171227	Tube, Yoke & Slip Sleeve	1	
9	RC901476	Bolt, 7/16-14 x 2 Gr 5 CZ Hex	1	Spares located under storage compartment cover
10	AB3171228	Shear, 55 Ball	1	
11	RC901581	Nut, 7/16-14 CZ Top Lock	1	Spares located under storage compartment cover
12	AB3171229	Kit, Slide Lock Repair	1	

10.3 – RH Control Valve

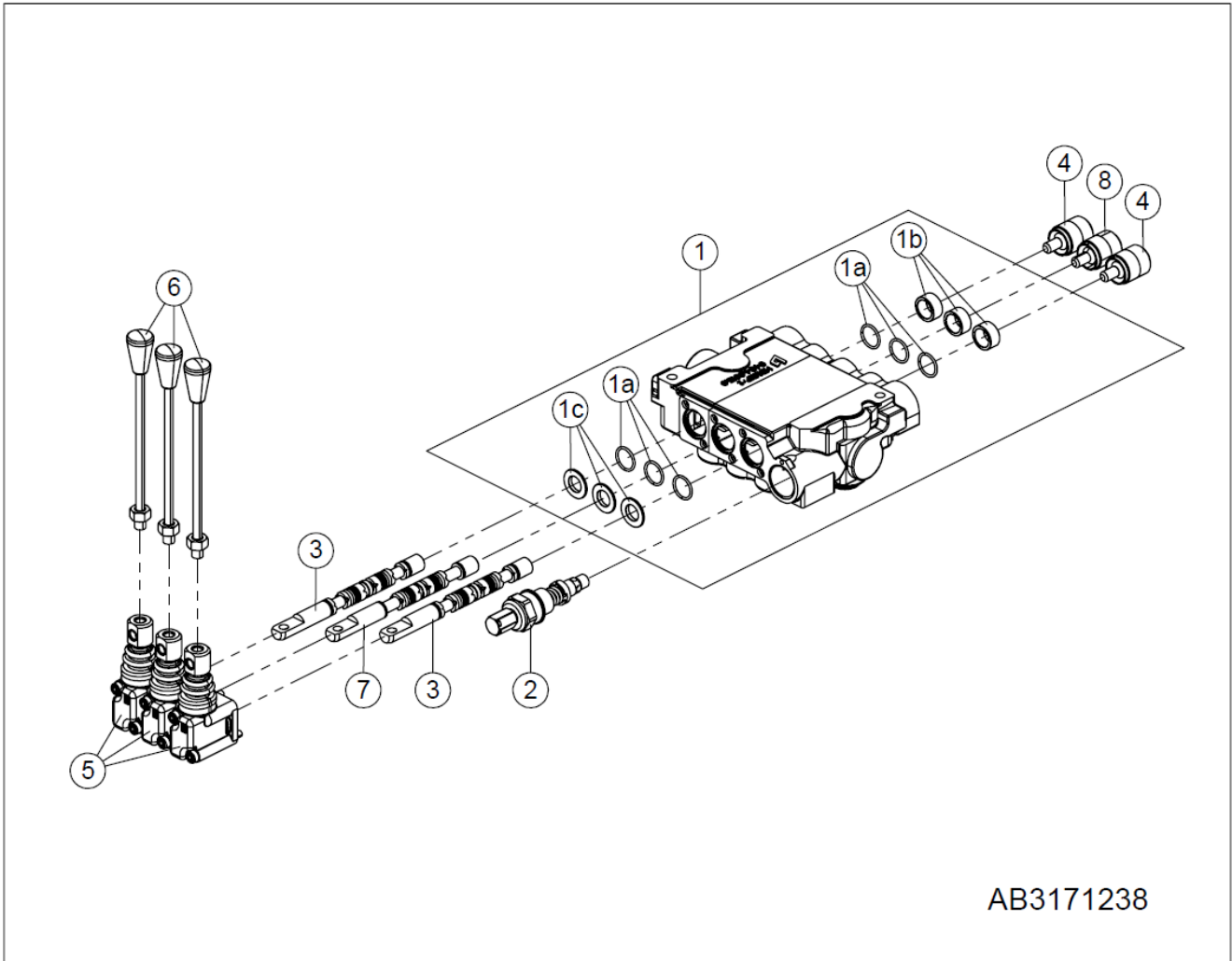

AB3171238

10.3 – RH Control Valve

Key	Part Number	Description	Qty	Comments
1	AB3172153	Body, Distributor	1	
1a	AB3171002	O-Ring	6	
1b	AB3171003	Spacer	3	
1c	AB3171004	Spacer, Open Slot	3	
2	AB3171005	Valve	1	
3	AB3171006	Spool, Type A	2	
4	AB3171008	Positioner	2	
5	AB3171010	Cap, Lever	3	
6	AB3171012	Lever, 150mm	3	
7	AB3171007	Spool, Type C	1	
8	AB3172154	Postioner	1	

10.4 – LH Control Valve

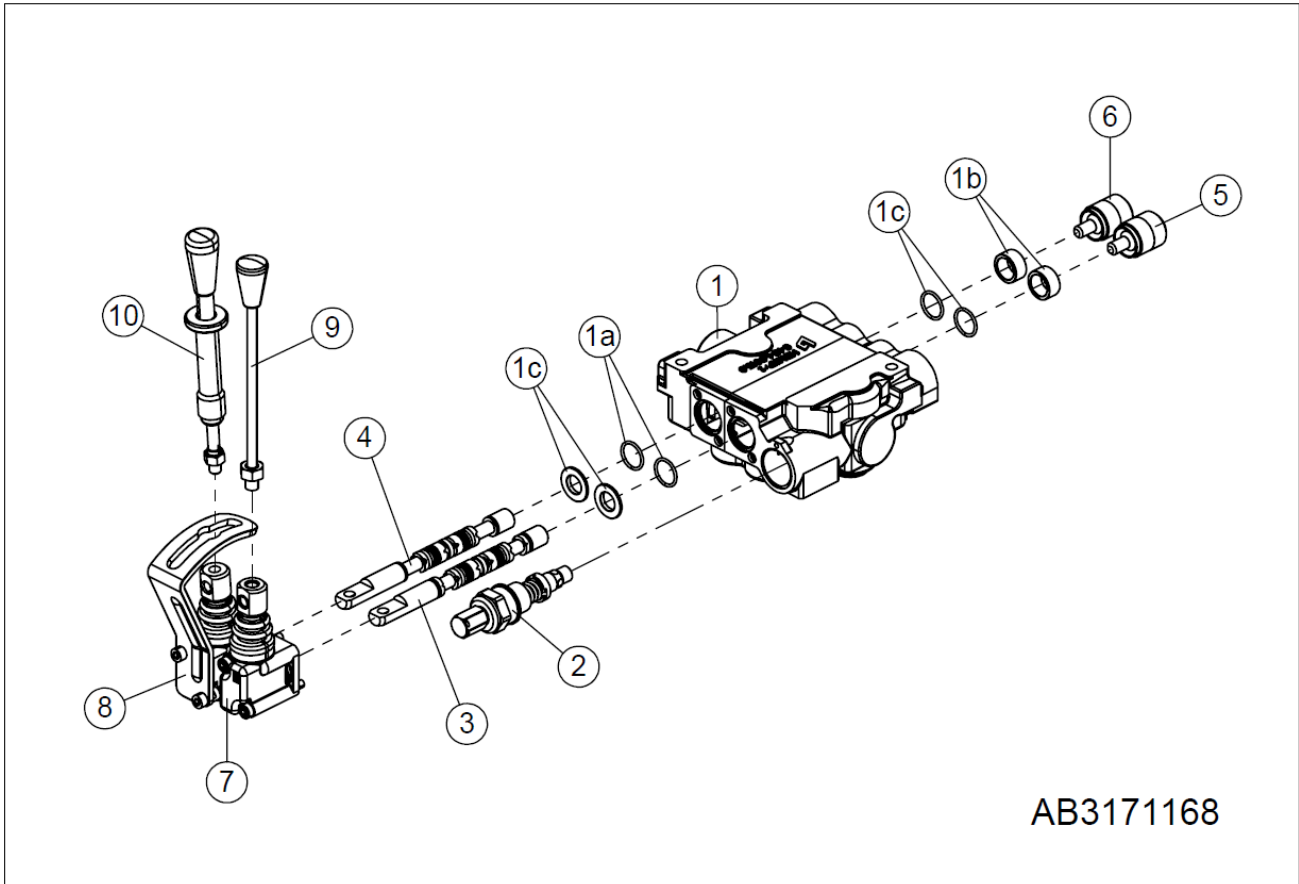

10.4 – LH Control Valve

Key	Part Number	Description	Qty	Comments
1	AB3171015	Body, Distributor	1	
1a	AB3171002	O-Ring	4	
1b	AB3171003	Spacer	2	
1c	AB3171004	Spacer, Open Slot	2	
2	AB3171005	Valve	1	
3	AB3171006	Spool, Type A	1	
4	AB3171007	Spool, Type C	1	
5	AB3171008	Positioner	1	
6	AB3171014	Positioner	1	
7	AB3171010	Cap, Lever	1	
8	AB3171011	Cap, Locking Lever	1	
9	AB3171012	Lever, 150mm	1	
10	AB3171013	Lever, 140mm Locking	1	

10.5 – Hand Pump

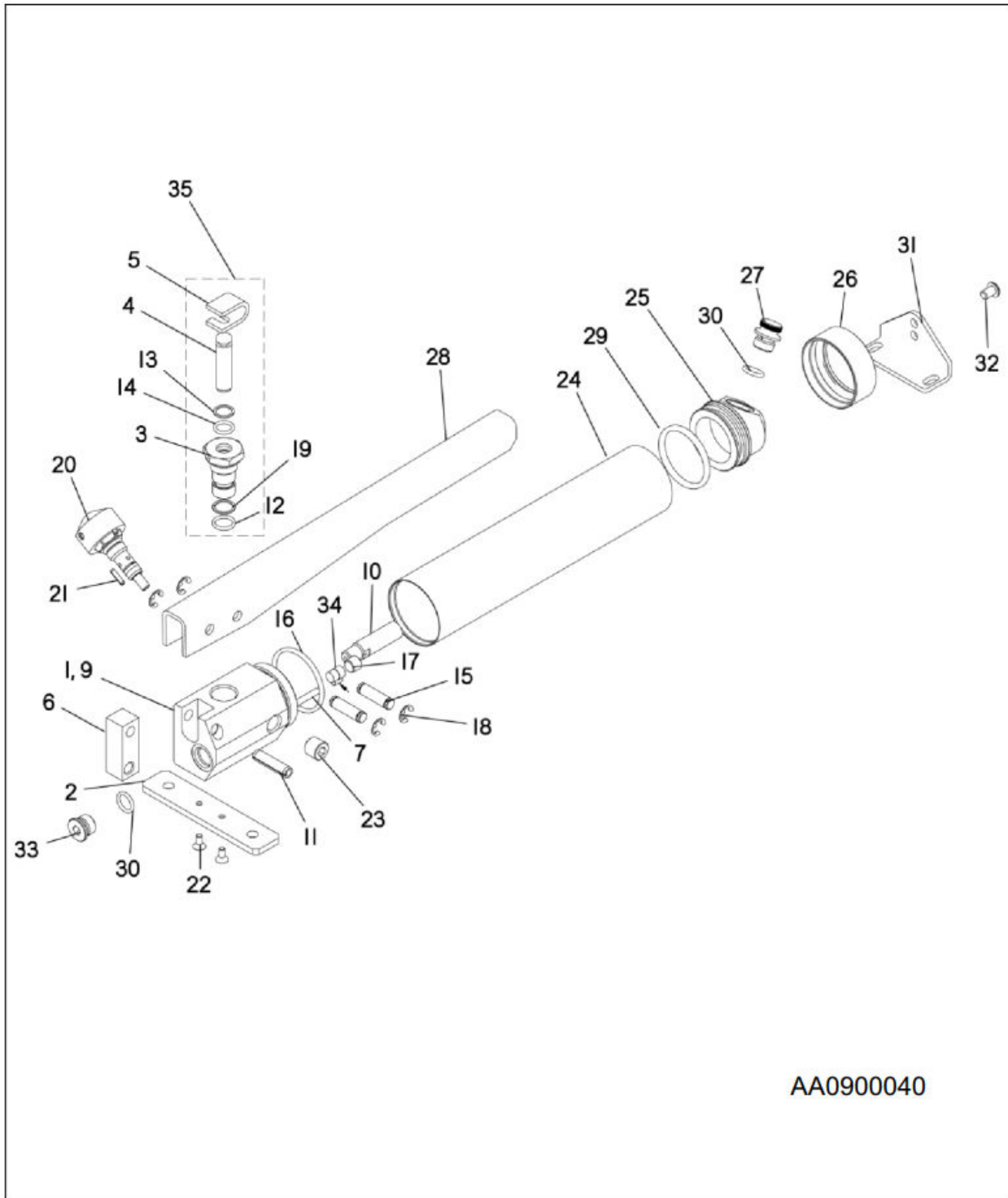

AA0900040

10.5 – Hand Pump

Key	Part Number	Description	Qty	Comments
4	AA0000646	Dowel, Machined Piston	1	
5	AA0000647	Tab, Piston	1	
20	AA0000555	Kit, Hydraulic Hand Pump Release	1	
22	AA0000648	Screw, #8-32 x 3/8 BO Flat Head Socket	2	
27	AA0000654	Plug, Hand Pump Filler	1	
30	AA0000655	O-Ring, Filler Plug	1	
35	AA0901970	Assembly, Hand Pump Cartridge	1	

10.6 – Brake Caliper

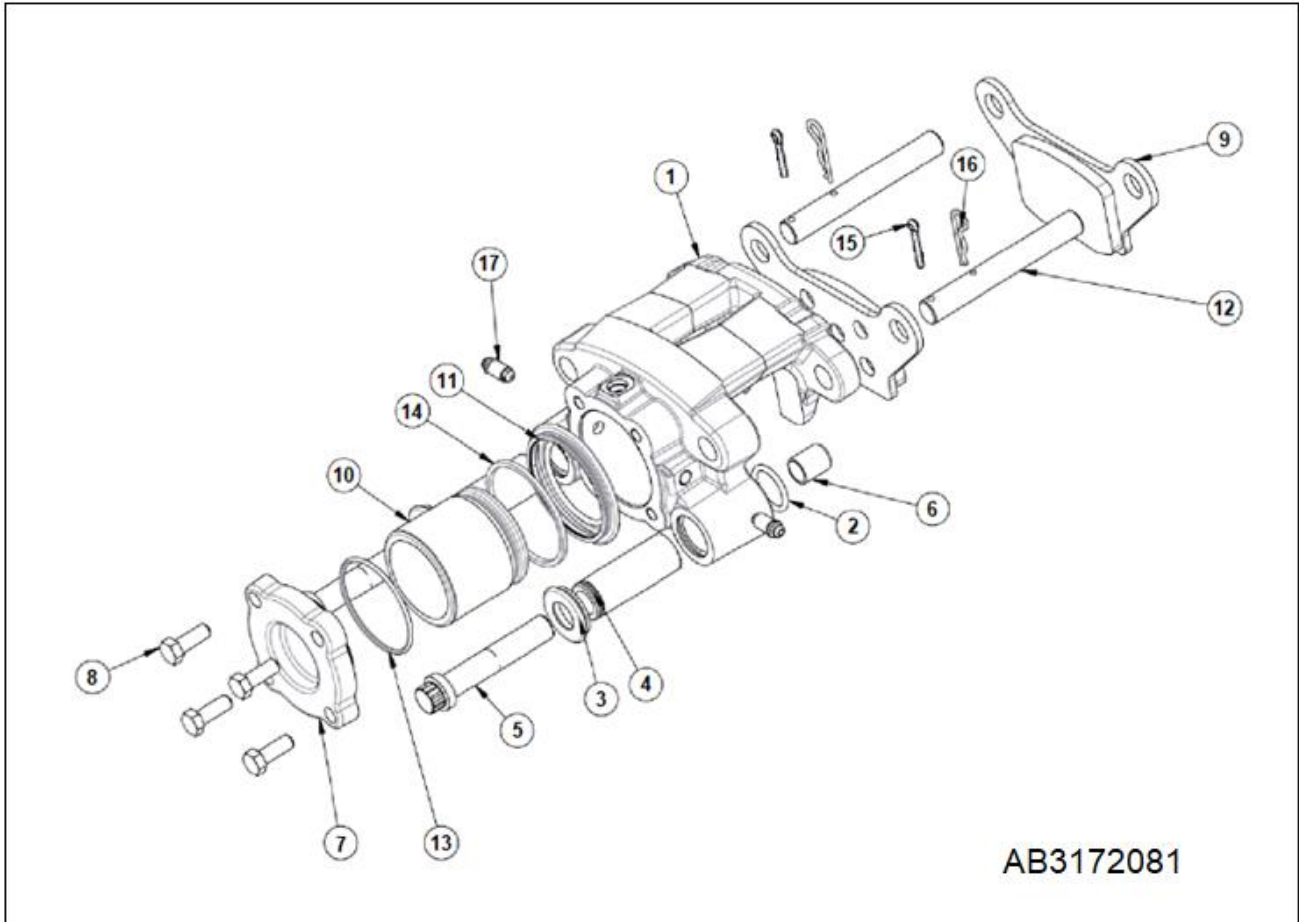

10.6 – Brake Caliper

Key	Part Number	Description	Qty	Comments
1	AB3172136	Housing, Machined	1	
2	AB3172137	O-Ring, I-633	2	
3	AB3172138	Boot, Dust	2	
4	AB3172139	Bushing, Slide	2	
5	AB3172140	Screw, 12 Point Flange	2	
6	AB3172141	Cap	2	
7	AB3172142	Cover, Machined	1	
8	AB3172143	Screw, 3/8-16 x 1	4	
9	AB3172144	Assembly, Pad and Holder	2	
10	AB3172145	Piston, I-663 1/2" Disc	1	
11	AB3172146	Boot, Brake Caliper Disc	1	
12	AB3172147	Pin, Pad	2	
13	AB3172148	O-Ring	1	
14	AB3172149	Seal, Piston	1	
15	AB3172150	Pin, Cotter	2	
16	AB3172151	Clip, Hair Pin	2	
17	AB3172152	Screw, 3/8-24 Bleeder	2	

10.7 – Spindle

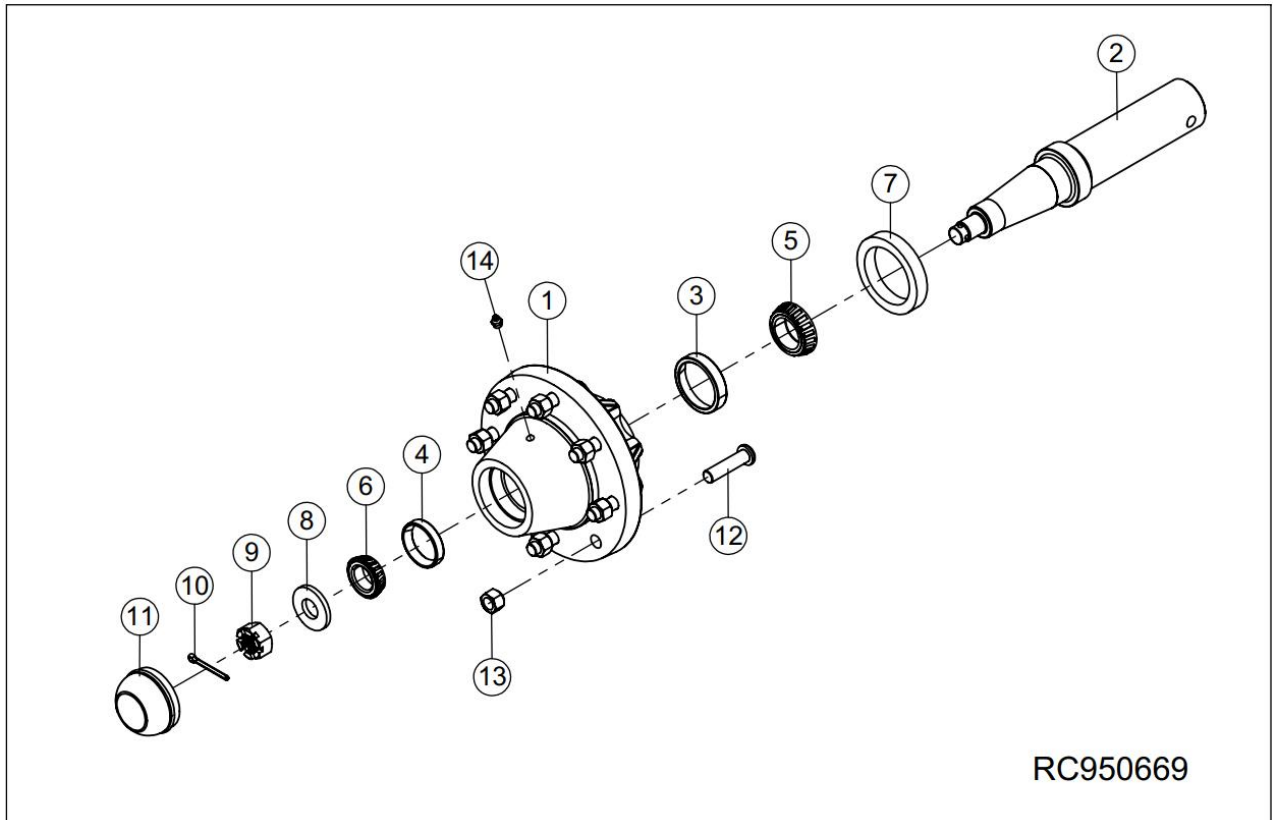

10.7 – Spindle

Key	Part Number	Description	Qty	Comments
1	RC950694	Hub, Cast	1	
2	RC950626	Spindle	1	
3	RC950623	Cup, Inner Bearing	1	
4	RC950624	Cup, Outer Bearing	1	
5	RC950627	Cone, Inner Bearing	1	
6	RC950628	Cone, Outer Bearing	1	
7	RC950695	Seal, Inner	1	
8	RC950696	Washer, Spindle	1	
9	RC950697	Nut, Hex Slotted	1	
10	RC902847	Pin, 7/32 x 2 CZ Cotter	1	
11	RC950698	Cap, Hub	1	
12	RC950625	Stud, 5/8-18UNF YZ Wheel	8	
13	RC950635	Nut, 5/8-18UNF Wheel	8	
14	RC901873	Zerk, 1/8 NPT Straight Grease	1	

10.8 – 2-Way Flow Divider

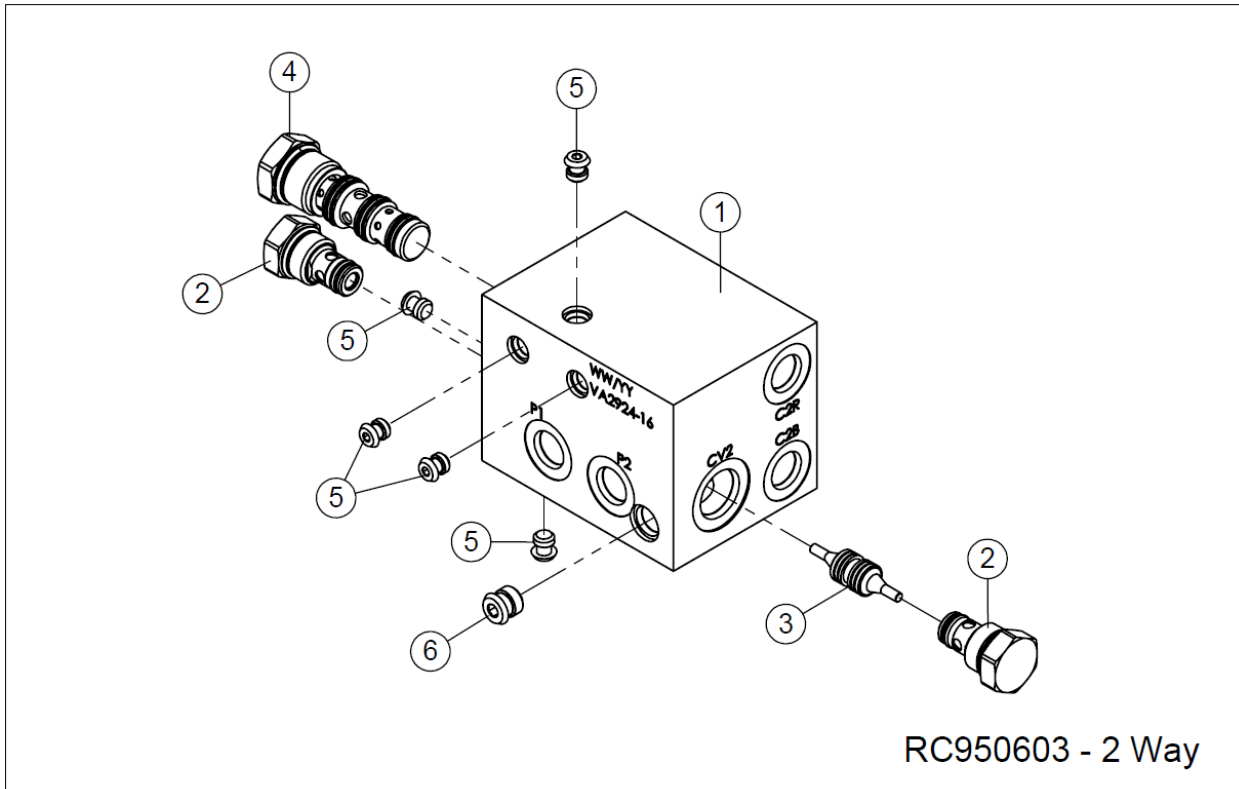

10.8 – 2-Way Flow Divider

Key	Part Number	Description	Qty	Comments
1	RC950602	Housing, #06 ORB x 2 Flow Divider	1	
2	RC950147	Valve, #08 25 PSI Check	2	(Seal Kit Key 7)
3	RC950604	Piston, #08 Pilot	1	
4	RC950605	Valve, #10 50:50, 4 GPM Input, Flow Divider	1	(Seal Kit Key 8)
5	RC950359	Stop, #2 Cavity Plug	5	
6	RC950362	Stop, #4 Cavity Plug	1	
7	RC950169	Kit, #08 2 Position, Buna N Seal	2	
8	RC950168	Kit, #10 4 Position, Buna N Seal	1	

10.9 – 3-Way Flow Divider

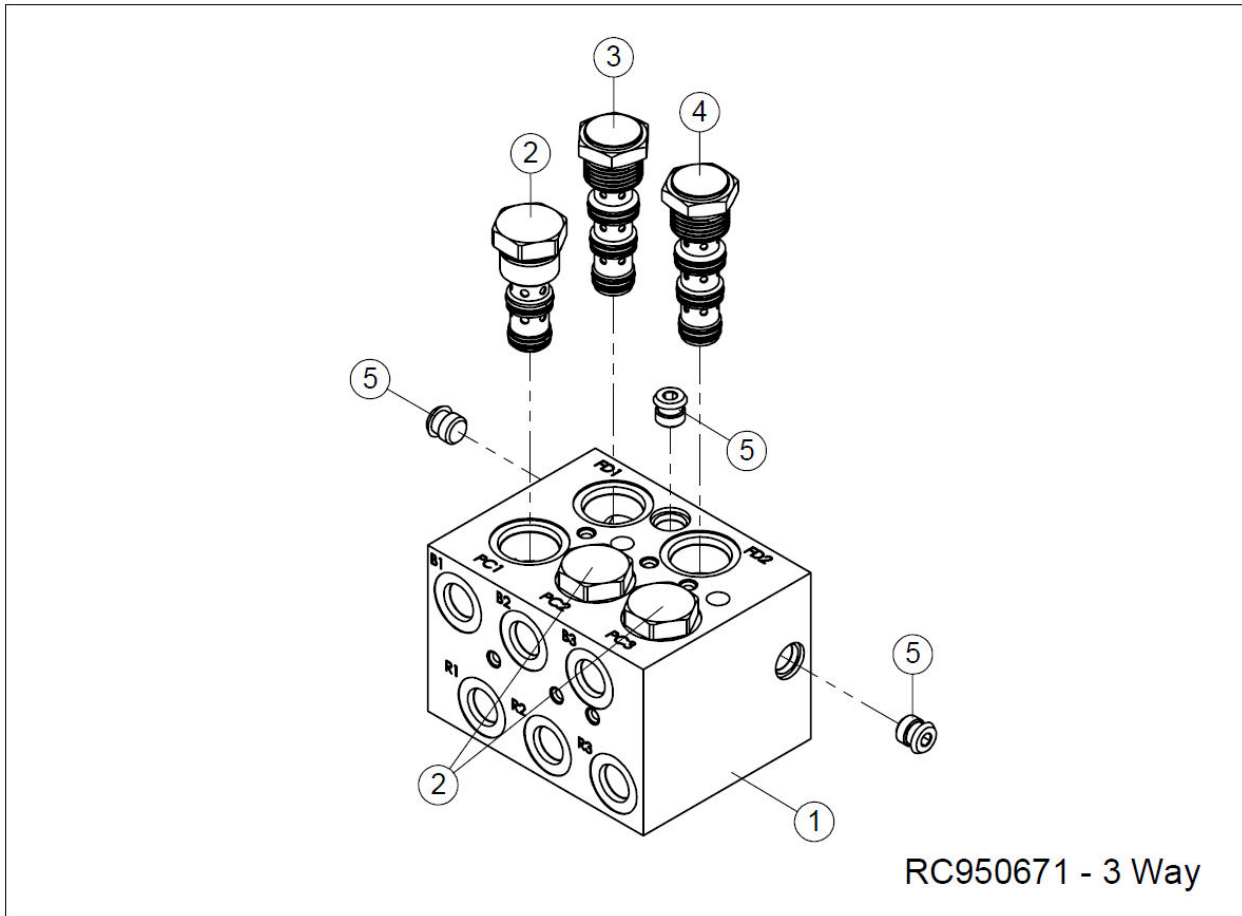

10.9 – 3-Way Flow Divider

Key	Part Number	Description	Qty	Comments
1	RC950675	Housing, 3-Way Flow Divider	1	
2	RC950676	Valve, #10 30 PSI Check	3	(Seal Kit Key 6)
3	RC950683	Valve, #10 66:33, 9 GPM Input, Flow Divider	1	(Seal Kit Key 7)
4	RC950684	Valve, #10 50:50, 6 GPM Input, Flow Divider	1	(Seal Kit Key 7)
5	RC950362	Stop, #4 Cavity Plug	3	
6	RC950685	Kit, #10 3 Way Seal	3	
7	RC950686	Kit, Seal	2	

10.10 – Gauge Station Assembly

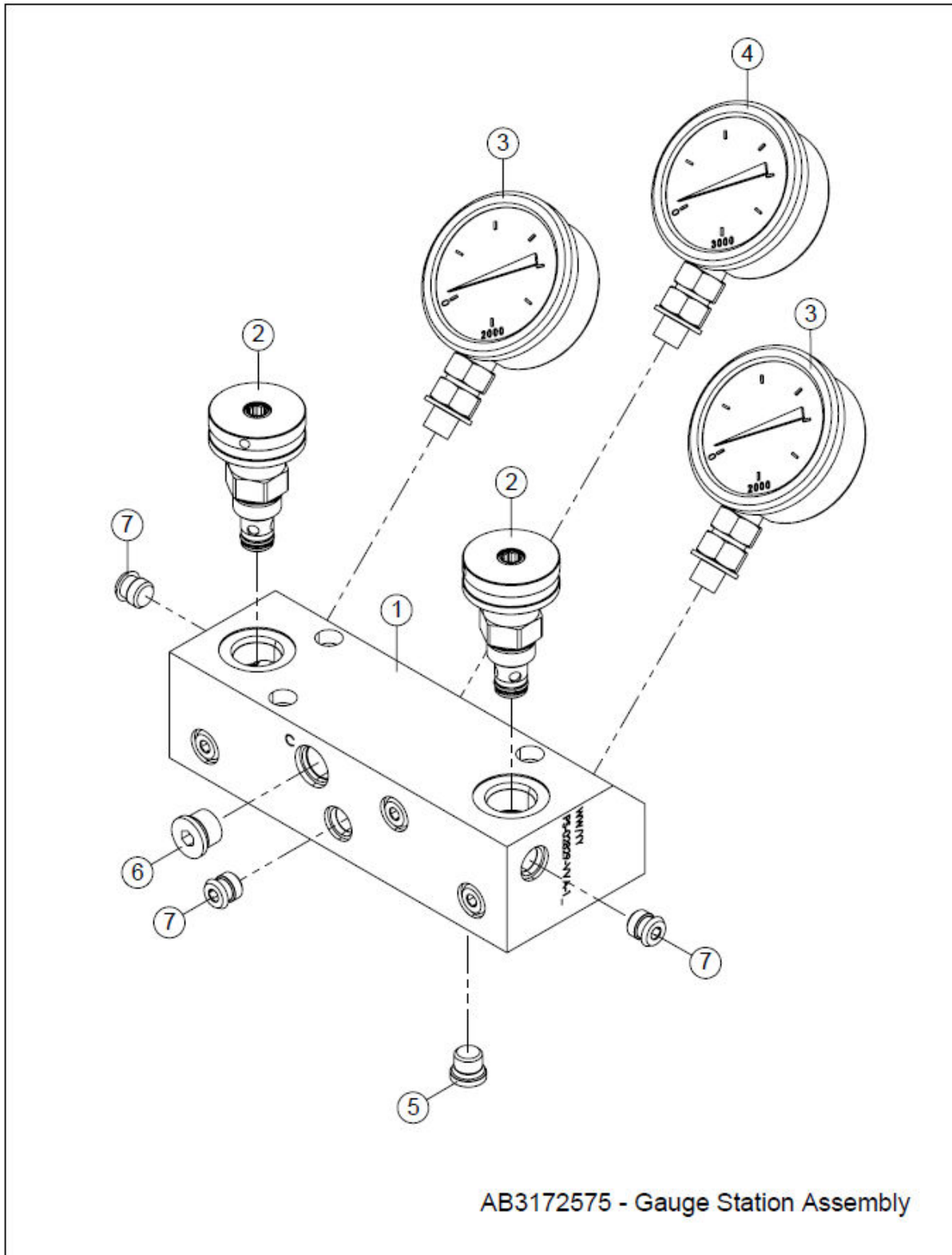

10.10 – Gauge Station Assembly

Key	Part Number	Description	Qty	Comments
1	AB3172576	Block, Brake Hand Pump Gauge Station	1	
2	RC950781	Valve, #8 Needle	2	(Seal Kit Key 8)
3	RC703184	Gauge, 2000 PSI 2-1/2" Stem Mount Pressure	2	
4	RC703185	Gauge, 3000 PSI 2-1/2" Stem Mount Pressure	1	
5	RC700619	Plug, -04 MORB Socket Head	1	
6	RC700620	Plug, -06 MORB Socket Head	1	
7	RC950362	Stop, #4 Cavity Plug	6	
8	RC950164	Kit, #08 2 Position, Buna N Seal	2	

11.1 – Gandy Option

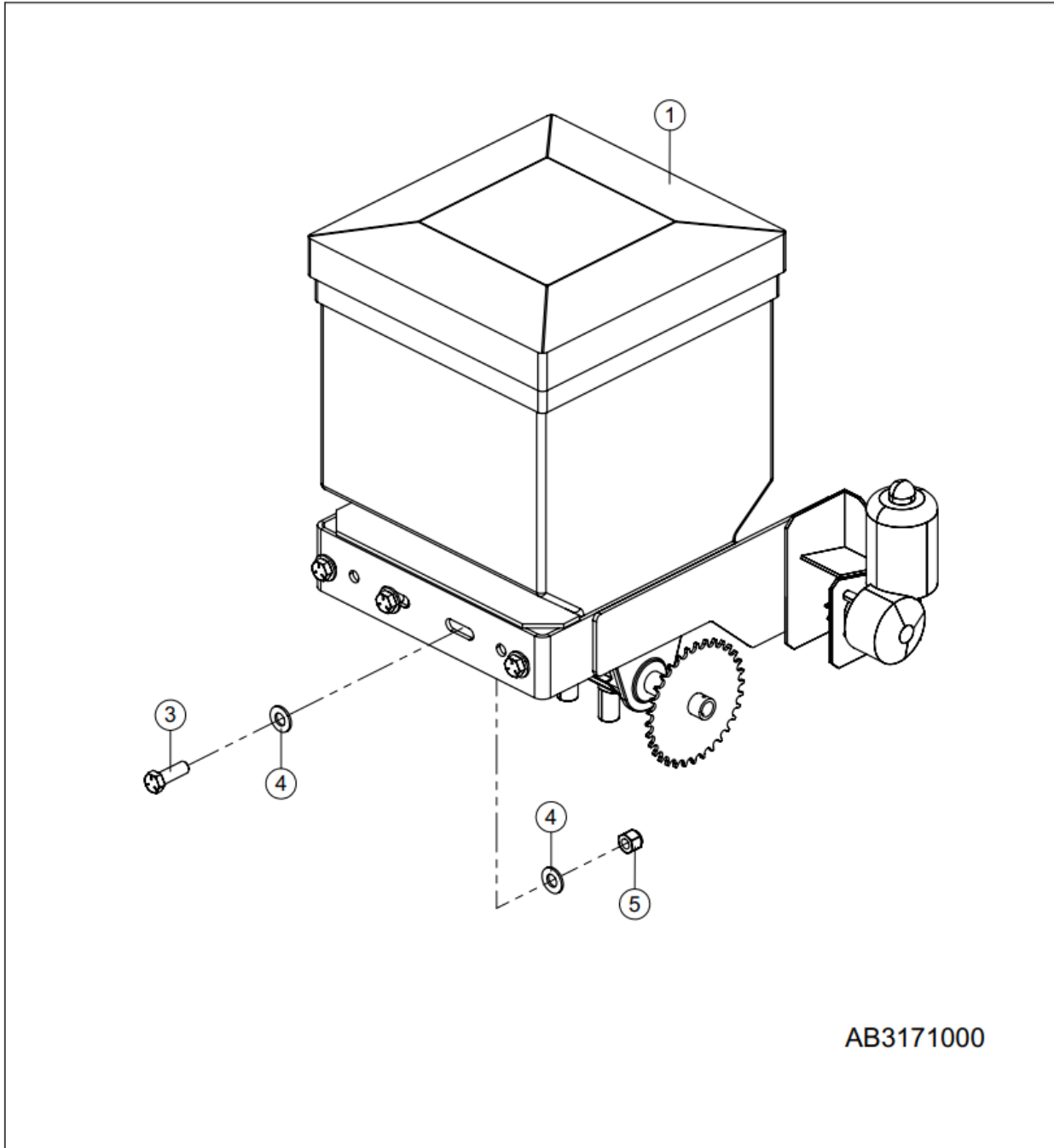

11.1 – Gandy Option

Key	Part Number	Description	Qty	Comments
1	AA1500005	Applicator, Gandy 45# 4H Dry Inoc	1	
2	AA0900838	Instructions, Gandy Mount Lightbar	1	
3	RC900135	Bolt, 1/2-13 x 1-1/2 Gr 5 YZ Hex	4	
4	RC900691	Washer, 1/2 SAE YZ Hard Flat	8	
5	RC900588	Nut, 1/2-13 YZ Nylock	4	

11.2 – Gandy Dry Inoculator

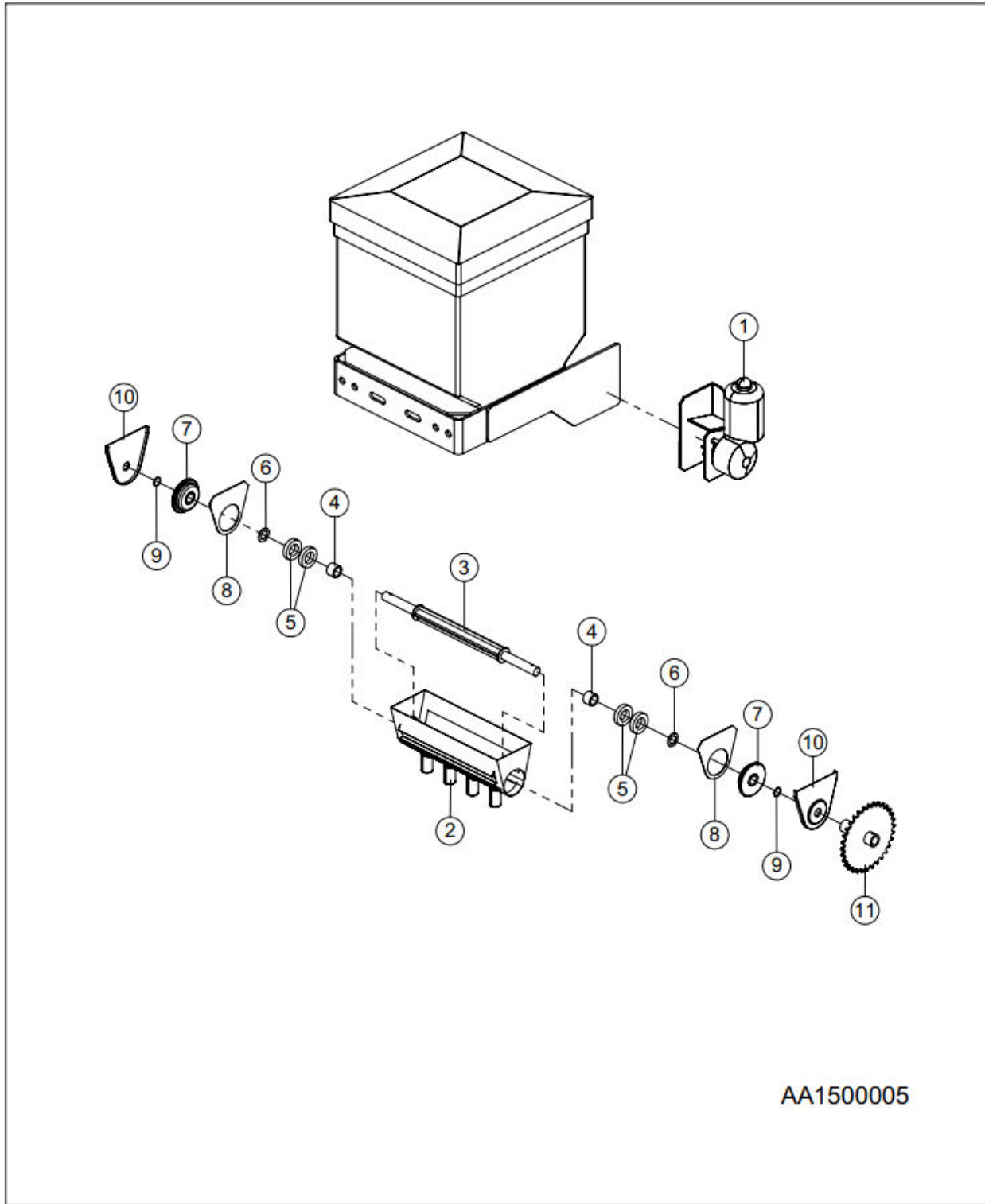

11.2 – Gandy Dry Inoculator

Key	Part Number	Description	Qty	Comments
1	AA1500276	Motor, Elec w/Brkt Sprkts Harness	1	
2	AA1500472	Slide, Jumbo 4 Hole Straight Bottom	1	
3	AA1500344	Rotor, Jumbo 10" Rubber Gandy	1	
4	AA3160475	Spacer	2	
5	AA1501991	Washer, 5/8 x 1-1/2 x 5/16 Rubber	4	
6	AA1501920	Washer, Gandy SS	2	
7	AA1501628	Bearing, Gandy	2	
8	AA1501621	Gasket, Gandy Bearing Retainer	2	
9	AA1501921	O-Ring, Gandy Rubber	2	
10	AA1501630	Retainer, Gandy Bearing	2	
11	AA1502070	Sprocket, Gandy 32 Tooth	1	
12	AA1500267	Masterseal, Box 14.5' (4pcs)	1	

11.3 – Miscellaneous Items

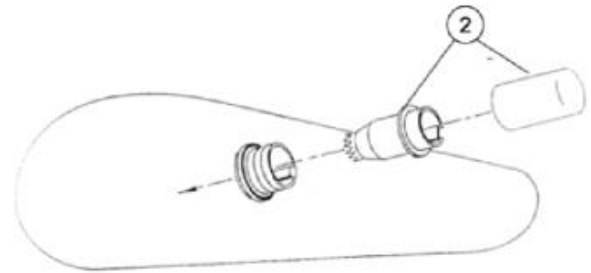
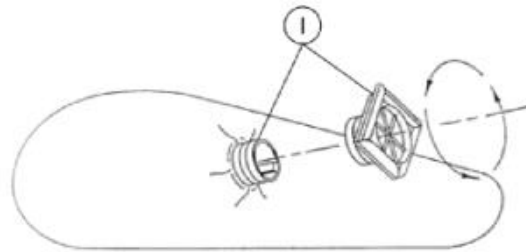
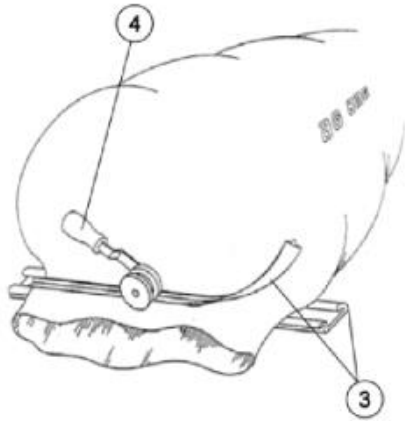

11.3 – Miscellaneous Items

Key	Part Number	Description	Qty	Comments
1	AA1500893	Valve, Bag Vent	AR	
2	AA1500568	Tool, Bag Vent	AR	
	AA1570001	Spray Adhesive - Not Shown	AR	
	AA1500523	Repair Tape, 2 in. x 36 Yard Roll - Not Shown	18/Case	
	AA1500525	Repair Tape, 3 in. x 36 Yard Roll - Not Shown	24/Case	
	AA1501331	Repair Tape, 4 in. x 36 Yard Roll - Not Shown	18/Case	
3	AA1500272	Master Seal, 250 Ft Roll	AR	
	AA1500270	Master Seal, 9.5 ft Lengths 4/Box	AR	
	AA1500267	Master Seal, 14.5 ft Lengths 4/Box For 8 & 9 ft Bags	AR	
	AA1500268	Master Seal, 17 ft Lengths 4/Box For 10 ft Bags	AR	
	AA1500269	Master Seal, 20 ft Lengths 4/Box For 11 & 12 ft Bags	AR	
4	AA1500273	Master Seal Zip Tool	AR	
5	AA908073	Kit, Ag Bag Green 1 Gal Urethane Paint	AR	
6	AA908074	Kit, Ag Bag Blue 1 Gal Urethane Paint	AR	
7	AA908076	Kit, Gray 1-1/4 Gal Primer	AR	
8	AA0000124	Paint, 12 oz. Ag-Bag Green Spray	AR	
9	AA0000126	Paint, 12 oz. Ag-Bag Blue Spray	AR	

12.1 – Grease Schematic

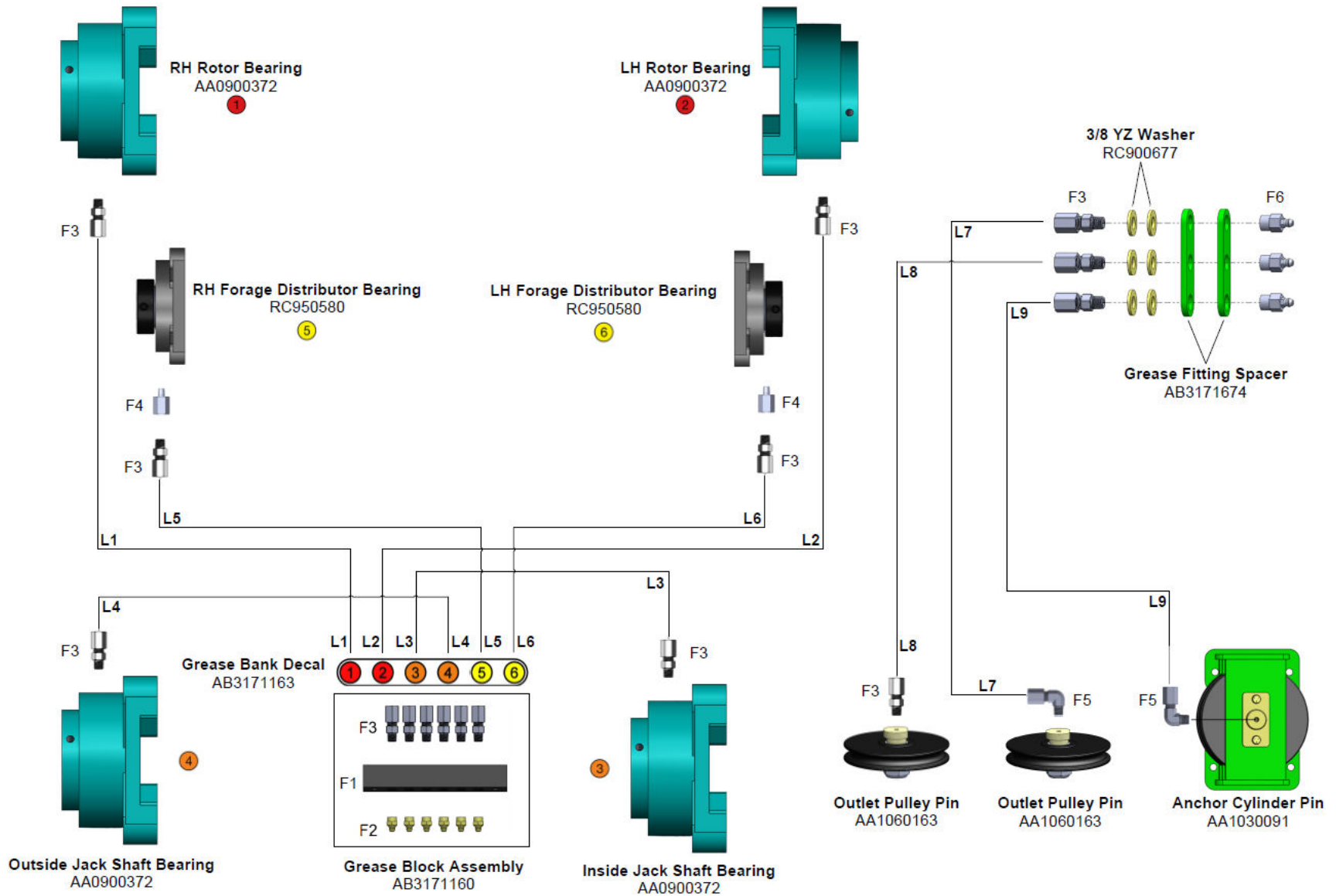

12.1 – Grease Schematic

Fittings

Key	Part Number	Description	Qty	Comments
F1	RC703129	Block, 6 Holder 90° 1/8" NPT Grease	1	
F2	RC901873	Zerk, 1/8 NPT Straight Grease	6	
F3	RC702704	Adapter, Straight ¼" Tube to 1/8"-27 MPT	15	
F4	RC702705	Adapter, 1/4-28 Taper Male x 1/8 NPTF Female Str	2	
F5	RC703162	Adapter, 1/4" Tube to 1/8" MPT 90 Deg	2	
F6	RC901968	Zerk, 1/8-27 FPT Straight Grease	3	

Grease Lines

Line #	Part Number	Length (in)	Qty	Routing
L1	AB3171788	55	1	Grease Bank Port 1 to RH Rotor Bearing
L2	AB3171789	143	1	Grease Bank Port 2 to LH Rotor Bearing
L3	AB3171790	38	1	Grease Bank Port 3 to Inside Shaft Bearing
L4	AB3171791	55	1	Grease Bank Port 4 to Outside Shaft Bearing
L5	AB3171792	56	1	Grease Bank Port 5 to RH Forage Distributor Bearing
L6	AB3171793	143	1	Grease Bank Port 6 to LH Forage Distributor Bearing
L7	AB3171976	95	1	Top Grease Zerk to LH Anchor Pulley Pin
L8	AB3171977	146	1	Middle Grease Zerk to RH Anchor Pulley Pin
L9	AB3171794	20	1	Bottom Grease Zerk to Anchor Cylinder Base Pulleys Pin

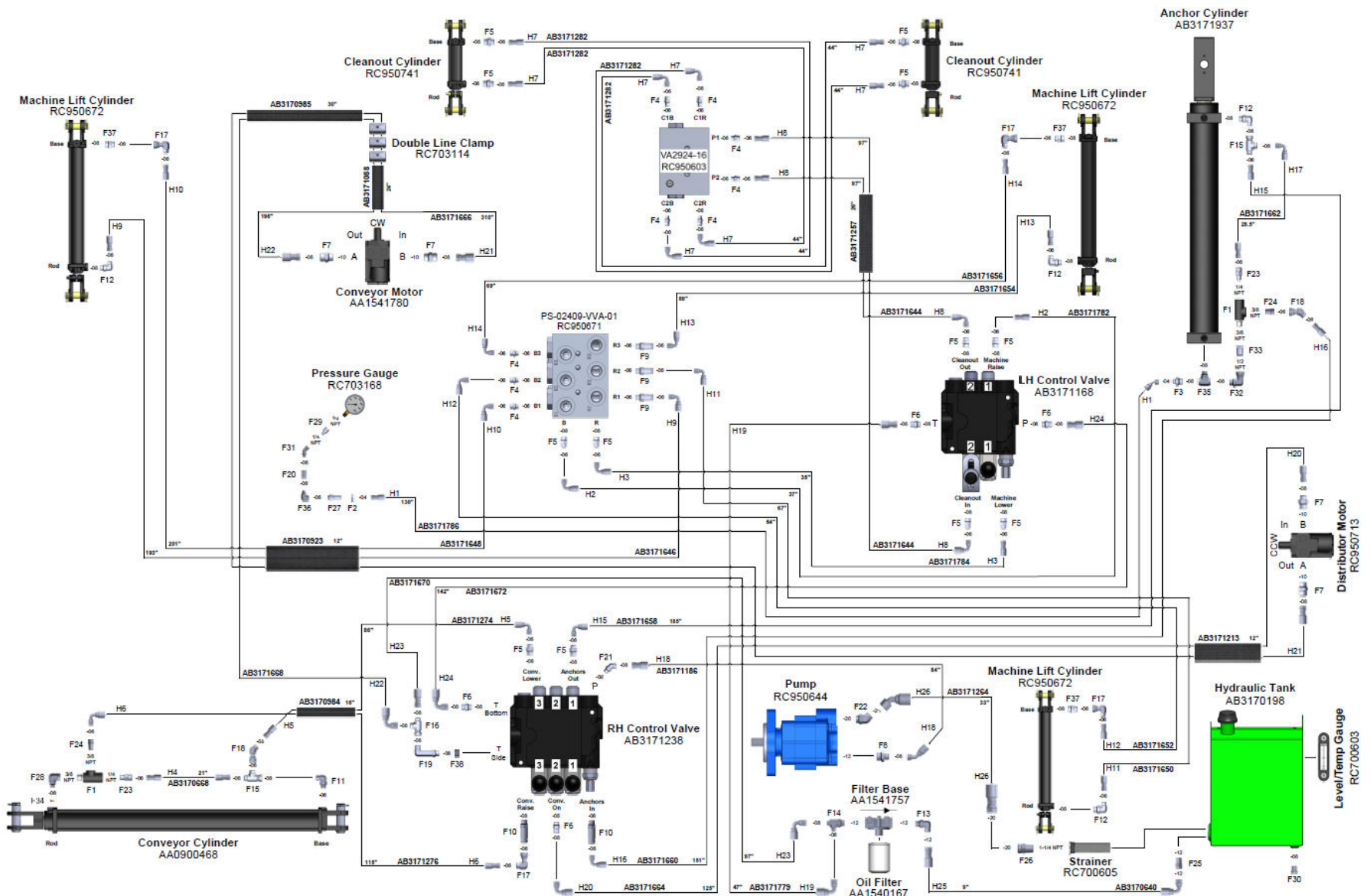

12.2 – Hydraulic Schematic S/N up to 401098

Download PDF version of manual from website to enlarge schematic for ease of component identification.

12.2 – Hydraulic Schematic S/N up to 401098

Hydraulic Fittings

Fitting#	RCI Part #	Description	Qty	Comments
F1	AA1700863	Valve, Pilot Check	2	
F2	RC700010	Nut, 9/16-18 Bulkhead Lock	1	
F3	RC700075	Adapter, -04 MORFS -08 MORB Straight	1	
F4	RC700077	Adapter, -06 MORFS -06 MORB Straight	9	
F5	RC700078	Adapter, -06 MORFS -08 MORB Straight	12	
F6	RC700083	Adapter, -08 MORFS -08 MORB Straight	4	
F7	RC700084	Adapter, -08 MORFS -10 MORB Straight	4	
F8	RC700085	Adapter, -08 MORFS -12 MORB Straight	1	
F9	RC700107	Adapter, -06 MORFS x -06 MORB Straight Long	3	
F10	RC700108	Adapter, -06 MORFS x -08 MORB Straight Long	2	
F11	RC700118	Elbow, -06 MORFS -06 MORB 90°	1	
F12	RC700119	Elbow, -06 MORFS -08 MORB 90°	4	
F13	RC700133	Elbow, -12 MORFS -12 MORB 90°	1	
F14	RC700154	Tee, -08 MORFS -12 MORB -08 MORFS Run	1	
F15	RC700156	Tee, -06 ORFS Run Thru	2	
F16	RC700157	Tee, -08 ORFS Run Thru	1	
F17	RC700181	Elbow, -06 MORFS -06 FORFS Swivel 90°	4	
F18	RC700195	Elbow, -06 FORFS -06 MORFS 45°	2	
F19	RC700309	Elbow, -08 MORFS -08 MORB Long 90°	1	
F20	RC700406	Adapter, -06 FORB -06 FORB Straight	1	
F21	RC700884	Elbow, -08 MORFS -08 MORB 45°	1	
F22	RC700898	Elbow, -20 MORFS -20 MORB 45°	1	
F23	RC700978	Adapter, -06 MORFS 1/4-18 MPT Straight	2	
F24	RC700979	Adapter, -06 MORFS, -06 MPT Straight	2	
F25	RC700988	Adapter, -12 MORFS -12 MPT Straight	1	
F26	RC700995	Adapter, -20 MORFS -20 MPT Straight	1	
F27	RC701016	Adapter, -04 MORFS -06 MORB Straight BH	1	
F28	RC701027	Fitting, -06 MORB 3/8 FPT 90°	1	
F29	RC701096	Fitting, 1/4 MPT x 1/4 FPT Expander	1	
F30	RC701310	Plug, -08 External Hex Pipe	1	
F31	RC701488	Elbow, -06 MORB -04 FPT Swivel 45°	1	
F32	RC701516	Elbow, -08 MORB 1/2 FPT Swivel 90°	1	
F33	RC701272	Bushing, 1/2 MPT 3/8 FPT Reducer	1	
F34	RC702605	Orifice, -06 SAE x 0.049" Hole Disc	1	
F35	RC702612	Tee, -08 MORB Branch	1	
F36	RC703151	Union, -06 MORB -06 FORB 90°	1	
F37	RC703170	Adapter, -06 MORFS -08 MORB x .062" Orifice	3	
F38	RC950728	Plug, Power Beyond	1	

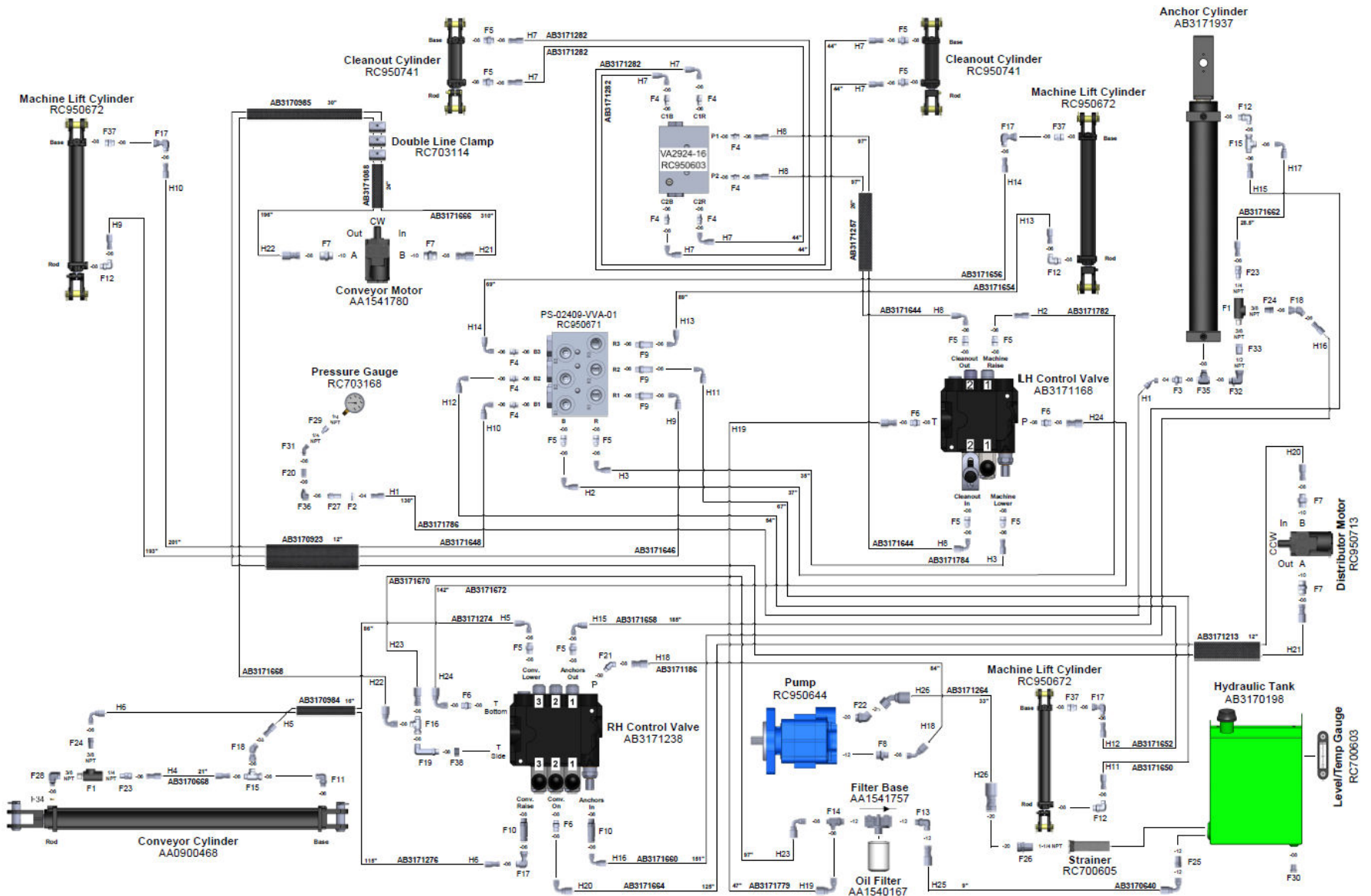

12.2 – Hydraulic Schematic S/N up to 401098 - Continued

Download PDF version of manual from website to enlarge schematic for ease of component identification.

12.2 – Hydraulic Schematic S/N up to 401098 - Continued

Hydraulic Hoses

Hose #	Part Number	Qty	Routing
H1	AB3171786	1	Anchor Cylinder Base to Pressure Gauge
H2	AB3171782	1	LH Control Valve to Machine Lift Manifold Port B
H3	AB3171784	1	LH Control Valve to Machine Lift Manifold Port R
H4	AB3170668	1	Conveyor Cylinder Check Valve
H5	AB3171274	1	RH Control Valve to Conveyor Cylinder Base
H6	AB3171276	1	RH Control Valve to Conveyor Cylinder Rod
H7	AB3171282	4	Cleanout Flow Divider C1/2A&B to Cleanout Cylinders
H8	AB3171644	2	LH Control Valve to Cleanout Manifold Port P1/P2
H9	AB3171646	1	Machine Lift Manifold Port R1 to RH Lift Cylinder Rod
H10	AB3171648	1	Machine Lift Manifold Port B1 to RH Lift Cylinder Base
H11	AB3171650	1	Machine Lift Manifold Port R2 to Center Lift Cylinder Rod
H12	AB3171652	1	Machine Lift Manifold Port B2 to Center Lift Cylinder Base
H13	AB3171654	1	Machine Lift Manifold Port R3 to LH Lift Cylinder Rod
H14	AB3171656	1	Machine Lift Manifold Port B3 to LH Lift Cylinder Base
H15	AB3171658	1	RH Control Valve to Anchor Cylinder Rod
H16	AB3171660	1	RH Control Valve to Anchor Cylinder Base
H17	AB3171662	1	Anchor Cylinder Base to Anchor Cylinder Rod
H18	AB3171186	1	Pump to RH Control Valve Port P
H19	AB3171779	1	LH Control Valve to Filter
H20	AB3171664	1	RH Control Valve to Distributor Motor Port B
H21	AB3171666	1	Distributor Motor Port A to Conveyor Motor Port B
H22	AB3171668	1	Conveyor Motor Port A to RH Control Valve Port T (Side)
H23	AB3171670	1	RH Control Valve Port T (Side) to Filter
H24	AB3171672	1	RH Control Valve Port T (Bottom) to LH Control Valve Port P
H25	AB3170640	1	Filter to Tank
H26	AB3171264	1	Tank to Pump Suction

THIS PAGE INTENTIONALLY LEFT BLANK



12.2 – Hydraulic Schematic S/N up to 401098 - Continued

Hydraulic Components

Part Number	Description	Qty	Comments
AA0900040	Pump, 17 CI 2000 PSI Hand	1	
AA0900468	Cylinder, 2 x 28 x 1.125 Hydraulic	1	
AA1500142	Gauge, 2000 PSI SM Liquid Sill	2	
AA1540167	Filter, Hydraulic P551553	1	
AA1541757	Base, Filter O-Ring	1	
AA1541780	Motor, 6070 Conveyor Hydraulic	1	
AB3170199	Assembly, Hydraulic Tank	1	
AB3170923	Sleeving, 12" C.L. 8" Ballistic Nylon Wrap-Around	1	
AB3170984	Sleeving, 16" C.L. 8" Ballistic Nylon Wrap-Around	1	
AB3171088	Sleeving, 24" C.L. 8" Ballistic Nylon Wrap-Around	1	
AB3171757	Sleeving, 26" C.L. 8" Ballistic Nylon Wrap-Around	1	
AB3170985	Sleeving, 30" C.L. 8" Ballistic Nylon Wrap-Around	1	
AB3171213	Sleeving, 12" C.L. 11" Ballistic Nylon Wrap-Around	1	
AB3171168	Valve, 2-Bank Hand Control	1	
AB3171238	Valve, 3-Bank Hand Control	1	
AB3171937	Cylinder, Dual Anchor	1	
RC700605	Strainer, In-Tank	1	
RC703114	Clamp, Double Line	3	
RC703168	Gauge, 0-3000 PSI 1/4 NPT Pressure	1	
RC950603	Assembly, #06 ORB x 2-Way Flow Divider	1	
RC950644	Pump, 2100 Series Gear	1	
RC950671	Assembly, 3-Way Flow Divider	1	
RC950672	Cylinder, 2" x 16" Tie Rod	3	
RC950713	Motor, Hydraulic	1	
RC950741	Cylinder, 3" x 8" Tie Rod	2	

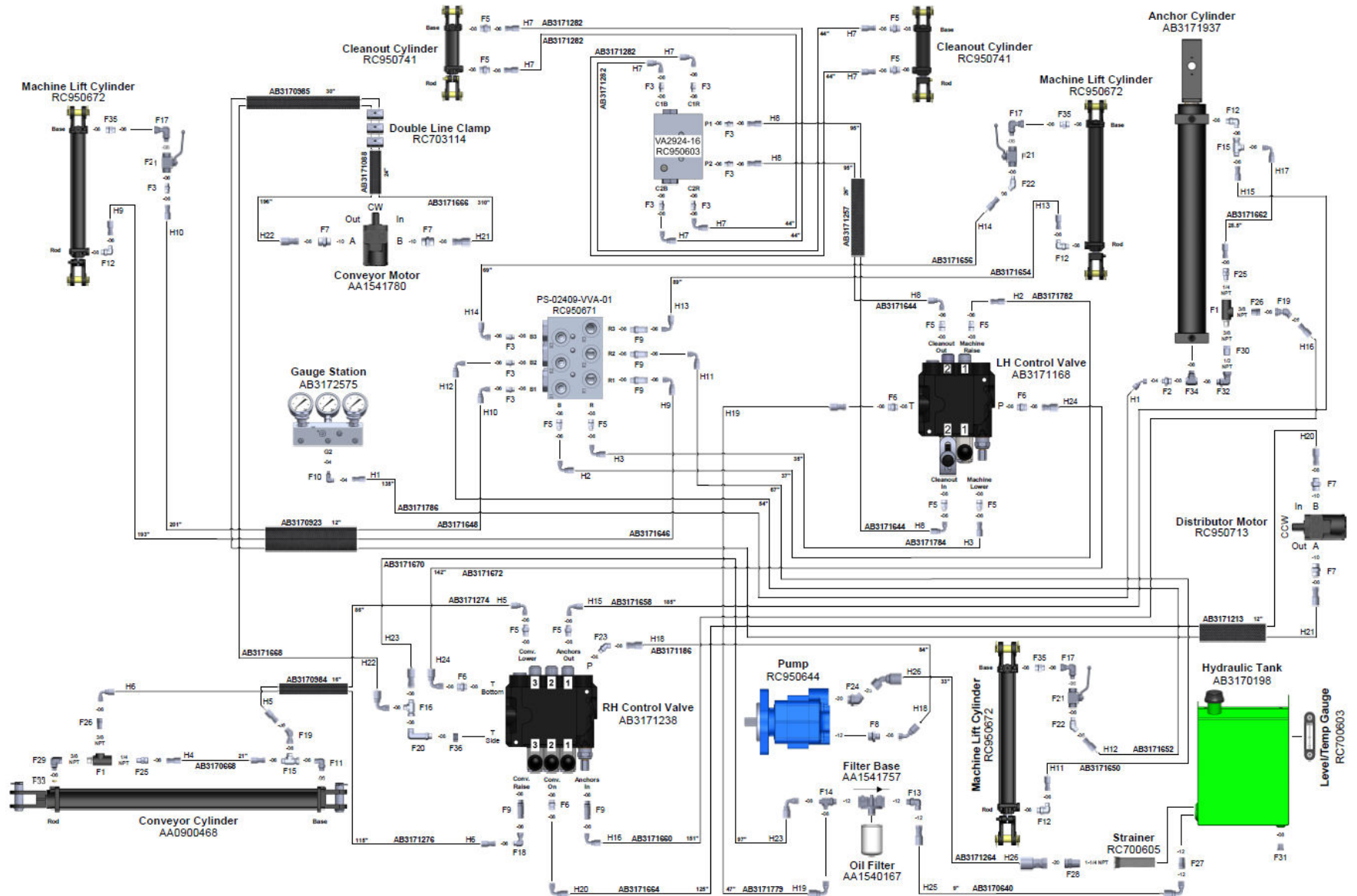

12.3 – Hydraulic Schematic S/N 401099 - X

Download PDF version of manual from website to enlarge schematic for ease of component identification.

12.3 – Hydraulic Schematic S/N 401099 – X

Hydraulic Fittings

Fitting#	Part Number	Description	Qty	Comments
F1	AA1700863	Valve, Pilot Check	2	
F2	RC700075	Adapter, -04 MORFS -08 MORB Straight	1	
F3	RC700077	Adapter, -06 MORFS -06 MORB Straight	10	
F4	RC700078	Adapter, -06 MORFS -08 MORB Straight	12	
F5	RC700083	Adapter, -08 MORFS -08 MORB Straight	4	
F6	RC700084	Adapter, -08 MORFS -10 MORB Straight	4	
F7	RC700085	Adapter, -08 MORFS -12 MORB Straight	1	
F8	RC700107	Adapter, -06 MORFS x -06 MORB Straight Long	3	
F9	RC700108	Adapter, -06 MORFS x -08 MORB Straight Long	2	
F10	RC700114	Elbow, -04 MORFS -04 MORB 90°	1	
F11	RC700118	Elbow, -06 MORFS -06 MORB 90°	1	
F12	RC700119	Elbow, -06 MORFS -08 MORB 90°	4	
F13	RC700133	Elbow, -12 MORFS -12 MORB 90°	1	
F14	RC700154	Tee, -08 MORFS -12 MORB -08 MORFS Run	1	
F15	RC700156	Tee, -06 ORFS Run Thru	2	
F16	RC700157	Tee, -08 ORFS Run Thru	1	
F17	RC700172	Adapter, -06 FORFS x -06 MORB 90°	3	
F18	RC700181	Elbow, -06 MORFS -06 FORFS Swivel 90°	1	
F19	RC700195	Elbow, -06 FORFS -06 MORFS 45°	2	
F20	RC700309	Elbow, -08 MORFS -08 MORB Long 90°	1	
F21	RC700389	Valve, -06 FORB Ball	3	
F22	RC700880	Elbow, -06 MORFS -06 MORB 45°	2	
F23	RC700884	Elbow, -08 MORFS -08 MORB 45°	1	
F24	RC700898	Elbow, -20 MORFS -20 MORB 45°	1	
F25	RC700978	Adapter, -06 MORFS 1/4-18 MPT Straight	2	
F26	RC700979	Adapter, -06 MORFS, -06 MPT Straight	2	
F27	RC700988	Adapter, -12 MORFS -12 MPT Straight	1	
F28	RC700995	Adapter, -20 MORFS -20 MPT Straight	1	
F29	RC701027	Fitting, -06 MORB 3/8 FPT 90°	1	
F30	RC701272	Bushing, 1/2 MPT 3/8 FPT Reducer	1	
F31	RC701310	Plug, -08 External Hex Pipe	1	
F32	RC701516	Elbow, -08 MORB 1/2 FPT Swivel 90°	1	
F33	RC702605	Orifice, -06 SAE x 0.049" Hole Disc	1	
F34	RC702612	Tee, -08 MORB Branch	1	
F35	RC703170	Adapter, -06 MORFS -08 MORB x .062" Orifice	3	
F36	RC950728	Plug, Power Beyond	1	

***12.3 – Hydraulic Schematic S/N 401099 – X – Continued**

Hydraulic Hoses

Hose #	Part Number	Qty	Routing
H1	AB3171786	1	Anchor Cylinder Base to Pressure Gauge
H2	AB3171782	1	LH Control Valve to Machine Lift Manifold Port B
H3	AB3171784	1	LH Control Valve to Machine Lift Manifold Port R
H4	AB3170668	1	Conveyor Cylinder Check Valve
H5	AB3171274	1	RH Control Valve to Conveyor Cylinder Base
H6	AB3171276	1	RH Control Valve to Conveyor Cylinder Rod
H7	AB3171282	4	Cleanout Flow Divider C1/2A&B to Cleanout Cylinders
H8	AB3171644	2	LH Control Valve to Cleanout Manifold Port P1/P2
H9	AB3171646	1	Machine Lift Manifold Port R1 to RH Lift Cylinder Rod
H10	AB3171648	1	Machine Lift Manifold Port B1 to RH Lift Cylinder Base
H11	AB3171650	1	Machine Lift Manifold Port R2 to Center Lift Cylinder Rod
H12	AB3171652	1	Machine Lift Manifold Port B2 to Center Lift Cylinder Base
H13	AB3171654	1	Machine Lift Manifold Port R3 to LH Lift Cylinder Rod
H14	AB3171656	1	Machine Lift Manifold Port B3 to LH Lift Cylinder Base
H15	AB3171658	1	RH Control Valve to Anchor Cylinder Rod
H16	AB3171660	1	RH Control Valve to Anchor Cylinder Base
H17	AB3171662	1	Anchor Cylinder Base to Anchor Cylinder Rod
H18	AB3171186	1	Pump to RH Control Valve Port P
H19	AB3171779	1	LH Control Valve to Filter
H20	AB3171664	1	RH Control Valve to Distributor Motor Port B
H21	AB3171666	1	Distributor Motor Port A to Conveyor Motor Port B
H22	AB3171668	1	Conveyor Motor Port A to RH Control Valve Port T (Side)
H23	AB3171670	1	RH Control Valve Port T (Side) to Filter
H24	AB3171672	1	RH Control Valve Port T (Bottom) to LH Control Valve Port P
H25	AB3170640	1	Filter to Tank
H26	AB3171264	1	Tank to Pump Suction

THIS PAGE INTENTIONALLY LEFT BLANK



12.3 – Hydraulic Schematic S/N 401099 – X

Hydraulic Components

Part Number	Description	Qty	Comments
AA0900468	Cylinder, 2 x 28 x 1.125 Hydraulic	1	
AA1540167	Filter, Hydraulic P551553	1	
AA1541757	Base, Filter O-Ring	1	
AA1541780	Motor, 6070 Conveyor Hydraulic	1	
AB3170199	Assembly, Hydraulic Tank	1	
AB3170923	Sleeving, 12" C.L. 8" Ballistic Nylon Wrap-Around	1	
AB3170984	Sleeving, 16" C.L. 8" Ballistic Nylon Wrap-Around	1	
AB3171088	Sleeving, 24" C.L. 8" Ballistic Nylon Wrap-Around	1	
AB3171757	Sleeving, 26" C.L. 8" Ballistic Nylon Wrap-Around	1	
AB3170985	Sleeving, 30" C.L. 8" Ballistic Nylon Wrap-Around	1	
AB3171213	Sleeving, 12" C.L. 11" Ballistic Nylon Wrap-Around	1	
AB3171168	Valve, 2-Bank Hand Control	1	
AB3171238	Valve, 3-Bank Hand Control	1	
AB3171937	Cylinder, Dual Anchor	1	
AB3172575	Assembly, Brake Hand Pump Gauge Station	1	
RC700605	Strainer, In-Tank	1	
RC703114	Clamp, Double Line	3	
RC950603	Assembly, #06 ORB x 2 Flow Divider with PO Checks	1	
RC950644	Pump, 2100 Series Gear	1	
RC950671	Assembly, 3-Way Flow Divider with PO Checks	1	
RC950672	Cylinder, 2" x 16" Tie Rod	3	
RC950713	Motor, Hydraulic	1	
RC950741	Cylinder, 3" x 8" Tie Rod	2	

THIS PAGE INTENTIONALLY LEFT BLANK



18 PRE-DELIVERY CHECKLIST

(Keep in Manual – Send Copy to RCI)

After the Ag-Bagger is completely set up and prior to delivery, the following inspections **MUST** be made before delivery to the customer. Check off each item after prescribed action is taken.

- No parts of the unit have been damaged in shipment. Check for items such as dents, loose or missing parts, scratches, and cleanliness. Repair as needed.
- All bolts and fasteners are in place and tightly secured.
- The gearbox oil level is filled to the proper level.
- The hydraulic oil level is filled to the proper level.
- The conveyor slides properly and is properly lubricated.
- All guards, shields and decals are in place and securely attached.
- All chains are properly tightened and installed.
 - Conveyor Chain
 - Rotor Drive Chain
 - Hydraulic Pump Drive Chain
 - Jackshaft Chain Coupler
- Brake system properly tightens and releases.
- Brake discs are clean and rust free.
- Tunnel bungee cord is properly installed.
- Anchors are stored properly.

- Wheels are properly attached, and tires are properly inflated.
- Cylinders, hoses, and fittings are NOT damaged, leaking or loosely connected.
- All grease fittings have been properly lubricated and the drive chains oiled.
- The hitch fits properly in the transport and operating positions.
- The transport lights, SMV, and safety chain are properly installed and functioning properly.
- Tunnel is installed properly for transport.
- Bag boom works properly and is secured for transport.

Connect the Ag-Bagger to the appropriate RPM tractor and test run while checking that proper operation is exhibited by all components.

- Transport lights work properly.
- PTO shield turns freely.
- All drives and mechanisms are operating smoothly and properly adjusted.
- All hydraulic system components are functioning properly.

Initials: _____ Dealer Representative
 _____ Customer



19 DELIVERY CHECKLIST

(Keep in Manual – Send Copy to RCI)

The following checklist is an important reminder of valuable information that must be passed on to the customer at the time the Ag-Bagger is delivered.

Check off each item as you explain it to the customer.

- Present the customer the Operator Manual. Instruct them to be sure to read and completely understand its contents BEFORE attempting to operate the unit.
- Review the warranty.
- Explain and review with the customer the controls and safety equipment on the Ag-Bagger.
- Review with the customer the lubrication and maintenance chapters of the Operator Manual.
- Explain and review with the customer the PTO driveline information in the separate manual provided on the PTO driveline. Store the manual in the Operator Manual holder at the storage compartment on the Ag-Bagger.
- Direct the customer on how to use the table of contents of the Operator Manual as a quick page-locating guide.
- Direct the customer to visit Ag-Bag.com for a digital copy of this manual.
- Explain and review with the customer the safety information in the Operator Manual.
- Explain to the customer that regular lubrication and proper adjustments are required for continued, proper operation and long life.
- Explain and review with the customer the proper tractor and Ag-Bagger preparation for safe operation.
- Review the checklists and have the customer and the dealer representative initial the pages.
- Complete the Warranty Registration and Acknowledgements page and make copies of it and both checklist pages to send to Ag-Bag by RCI and keep copies for the dealership.

Initials: _____ Dealer Representative
 _____ Customer



20 WARRANTY REGISTRATION AND ACKNOWLEDGEMENTS

(Keep in Manual – Send Copy to RCI)

Save time sending copy to Ag-Bag and fill out online after this page is complete.



Bit.ly/Ag-BagReg

I acknowledge that all pre-delivery and all delivery checklist items were performed on this unit as outlined and reviewed with the customer at the time of delivery.

All work must be complete, and information provided, to properly register for warranty. Save copy of each inspection and this form at the dealership. Fill out form online for warranty or send to Ag-Bag by RCI directly.

(Photocopy, screen shot, and fax are all acceptable means of data transmission.)

Online: bit.ly/Ag-BagReg

Email: ag-bag@RCI.ag

Mail: Ag-Bag by RCI
208 River Knoll Drive
Mayville, WI 53050

Fax: 920-387-9806

Customer Signature

Model Number

Serial Number

Dealer Representative Name

Dealer Representative Signature

Dealer Name and Location

Date

Customer Contact Name

Customer Business Name

Customer Business Address

Customer Business City, State, ZIP

Customer Business Phone

Customer Business Email



Ag-Bag by RCI
RCI Engineering LLC
208 River Knoll Dr
Mayville, WI 53050
Toll free: (800) 334-7432
Ag-Bag@RCI.ag
www.ag-bag.com
www.rci.ag

Ag-Bag by RCI is a brand of RCI Engineering.

RCI reserves the right to make improvements in design and changes in specifications at any time without notice and without incurring any obligation to install them on units previously manufactured or sold. Specifications, descriptions, and illustrative materials herein are as accurate as known at the time of publication but are subject to change without notice.