



This manual is organized into groups, it is designed to make the locating of parts easier. The exploded drawings also show assembly paths. All parts listed are available from your authorized Ag-Bag® Dealer.

## **AG-BAGGER® MODELS**

### **G6060A G6060B G6060C**

### **G6070B G6070C PB6000**

THIS PAGE INTENTIONALLY LEFT BLANK

# PARTS

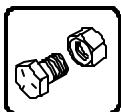

<i>FRAME GROUP</i> .....	4
<i>WHEEL GROUP</i> .....	6
<i>ROTOR GROUP</i> .....	8
<i>CABLE DRUM</i> .....	10
<i>TUNNEL with BAG BOOM OPTION</i> .....	12
<i>TUNNEL INTERCHANGEABLE HOOD with BAG BOOM OPTION</i> .....	14
<i>STANDARD CONVEYOR</i> .....	16
<i>SPLIT CONVEYOR</i> .....	20
<i>BACKSTOP</i> .....	22
<i>HYDRAULICS -G6060A - PB6000</i> .....	24
<i>HYDRAULIC PACKAGE OPTION - G6060B &amp; G6070B</i> .....	26
<i>HYDRAULIC PACKAGE OPTION - G6060C</i> .....	28
<i>HYDRAULIC PACKAGE OPTION - G6070C</i> .....	30
<i>HYDRAULIC CONVEYOR LIFT</i> .....	32
<i>SINGLE CABLE DRUM BRAKE ASSEMBLY</i> .....	34
<i>DOUBLE CABLE DRUM BRAKE ASSEMBLY</i> .....	36
<i>GANDY</i> .....	38
<i>MISCELLANEOUS</i> .....	40

# PARTS MANUAL

## FRAME GROUP

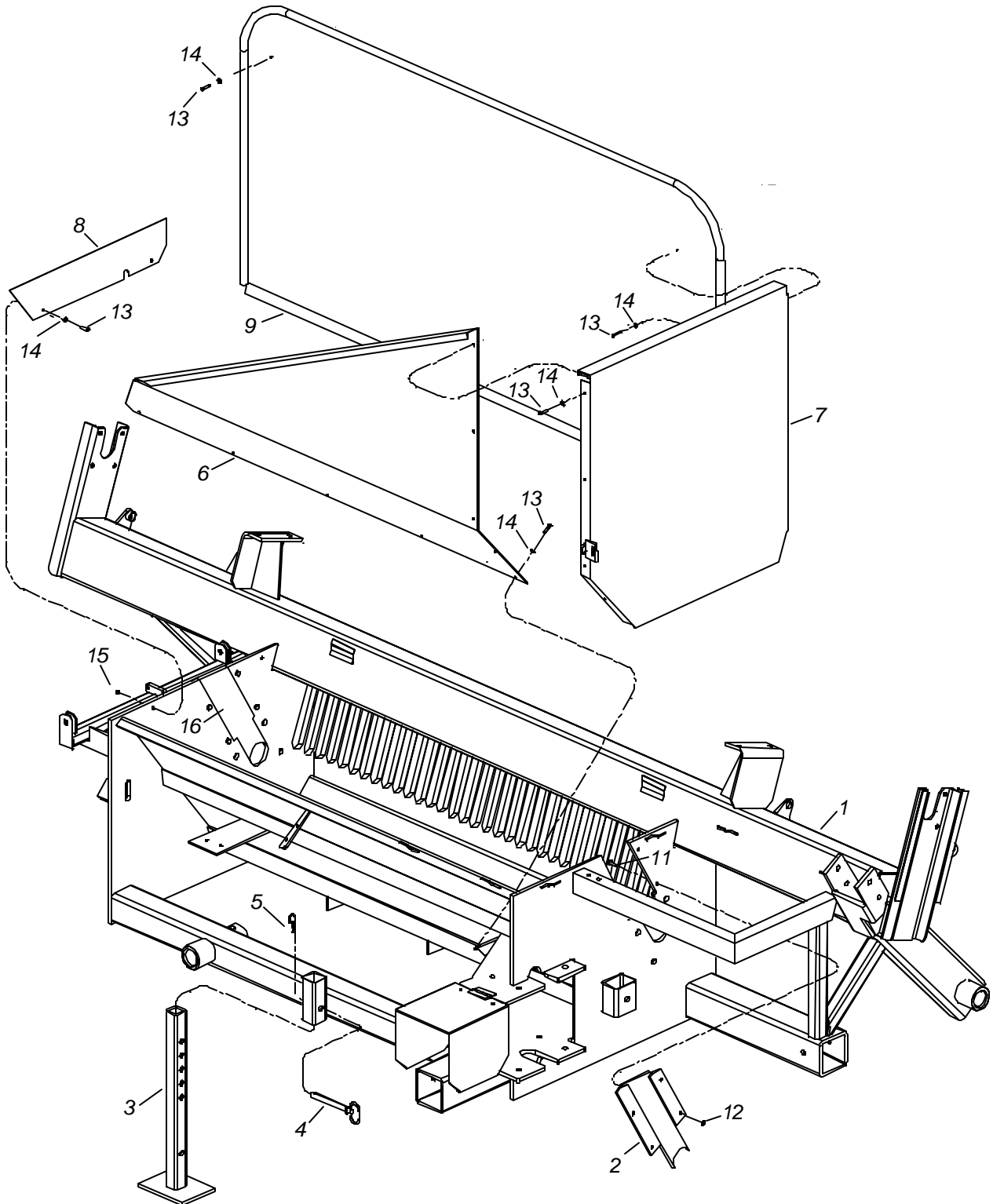

# PARTS MANUAL

## FRAME GROUP

Used On Legend  
 A - All Models    B - G6060  
 C - G6070        D - PB6000

Item#	Part #	Description	Qty.	Used On - Remarks
1	ref.	Frame	1	
2	6000033	Access Plate, Rotor - Short	1	A
3	6012012	Stand, Jack	1	B,C
4	1550172	Pin, Hitch	1	B, C
5	1550169	Pin, Hair	1	B, C
6	6000127	Panel, Hopper Front	1	C
	6012007	Panel, Hopper Front	1	B, D
7	6012010	Panel, Hopper Right	1	A
8	6012009	Panel, Hopper Left	1	A
9	6012011	Plate, Face	1	B,C
	6006110	Plate, Face	1	D
10	N/A			
11	1550059	Capscrew, Hex Head	8	
12	ref.	Nut, Hex	8	3/8"-16 NC Nyloc
13	ref.	Capscrew, Hex Head	16	1/4"20 NC x 1-1/4 G5
14	ref.	Washer, Flat	16	1/4" SAE
15	N/A			
16	6000036	Access Plate, Rotor-Conveyor Side	1	A

WHEEL GROUP

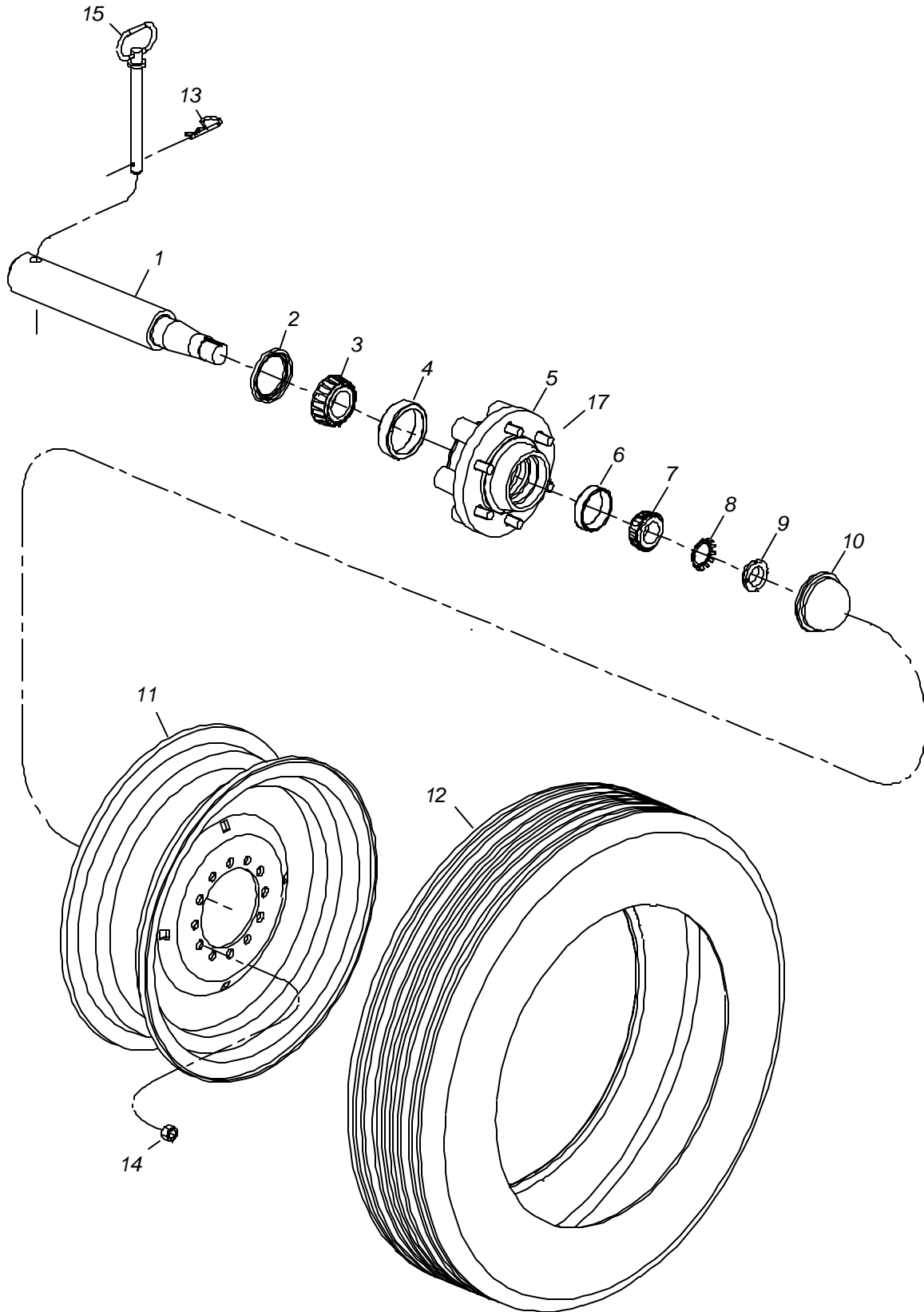

# PARTS MANUAL

## WHEEL GROUP

Used On Legend  
 A - All Models    B - G6060  
 C - G6070        D - PB6000

Item#	Part#	DESCRIPTION	Qty.	Remarks.
1	1010034	Spindle	2	B, C
	1502063	Spindle	2	D
2	1500377	Seal, Oil	2	A
3	1510090	Bearing, Roller Cone-Inner	2	A
4	1510073	Bearing, Roller Cup-Inner	2	A
5	1500182	Hub, Wheel w/out Washer, Nut, & Spindle	2	A
6	1510093	Bearing, Roller Cup-Outer	2	A
7	1510113	Bearing, Roller Cone-Outer	2	A
8	1550228	Washer, Lock-External Tooth	2	A
9	1550136	Nut, Lock	2	A
10	1500862	Cap, Dust	2	A
11	1500329	Rim	2	A
12	ref.	Tire, 95L 15 Farm Imp	2	D
		Tire, 235/85R 16	2	B
		Tire, 265/75R16	2	C
	1501520	Tire With Rim	2	B
	1501707	Tire With Rim	2	C
	1502073	Tire With Rim	2	D
13	1550169	Pin, Hair	2	A
14	1550309	Nut, Hub Lug	12	A
15	1150171	Pin, Hitch	2	B, C
16	1501374	Hub, Wheel with Spindle Complete	2	B, C
	1502069	Hub, Wheel with Spindle Complete	2	D
17	1550428	Bolt, Stud	12	2-1/8 Drive In

ROTOR GROUP

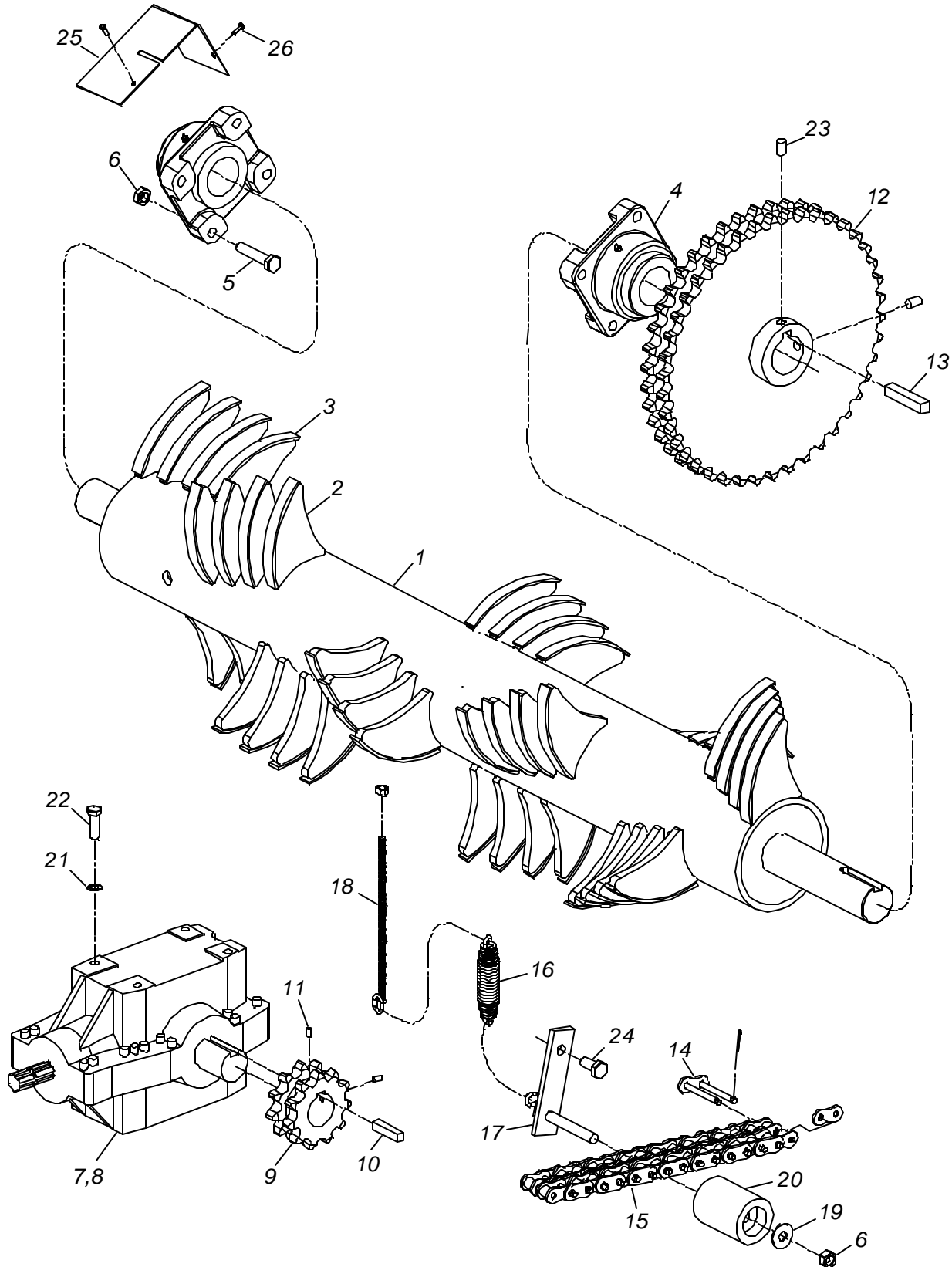



# PARTS MANUAL

## ROTOR GROUP

Used On Legend  
 A - All Models    B - G6060  
 C - G6070        D - PB6000

Item#	Part#	DESCRIPTION	Qty.	Used On - Remarks
1	6002033	Rotor, W/O Teeth	1	C
	6002019	Rotor, W/O Teeth	1	B, D
2	1020018	Tooth, Rotor with Tine Cap	48	B
		Tooth, Rotor with Tine Cap	56	C
		Tooth, Rotor with Tine Cab	36	D
3	1020001	Cap, Tine	48	B
		Cap, Tine	56	C
		Cap, Tine	36	D
4	1510024	Bearing	2	A
5	ref.	Capscrew, Hex Head	8	3/4"-10 NC x 3-1/2" G5
6	ref.	Nut, Hex	8	3/4"-10 NC Nyloc
7	1520051	Gearbox	1	D
8	1520050	Gearbox (Hydraulic Package)	1	B, C
9	1520664	Sprocket	1	A
10	6002002	Key	1	A
11	ref.	Set Screw	2	5/8" x 5/8"
12	1520756	Sprocket	1	C
	1520124	Sprocket	1	B, D
13	1120536	Key	1	C
	4070028	Key	1	B, D
14	1520068	Link, Roller Chain Connecting	1	A
15	1520757	Chain Roller	1	C
	1520005	Chain Roller	1	B, D
16	1500483	Spring	1	A
17	6002006	Support, Chain Tensioner Lever	1	A
18	6002010	Adjuster, Rotor Chain Tensioner	1	A
19	ref.	Washer	1	3/4" Flat
20	6002007	Tensioner, Rotor Chain	1	A
21	ref.	Washer	8	5/8" Split Lock
22	ref.	Capscrew, Hex Head	8	5/8"-11 NC x 2"
23	ref.	Set Screw	2	5/8" x 5/8"
24	ref.	Capscrew, Hex Head	1	3/4"-10 NC x 1-1/2" G5
25	6002028	Cover, Rotor Idle Bearing	1	B, C
26	ref.	Screw, Self Tapping	2	1/4"
ref	1501517	Whip, Grease Whip 20-1/2 (Not Shown)	1	A
ref	1501518	Whip, Grease Whip 28 (Not Shown)	1	A
ref	1501611	Fitting, Hose End Swivel	2	Use with Grease Whips

CABLE DRUM

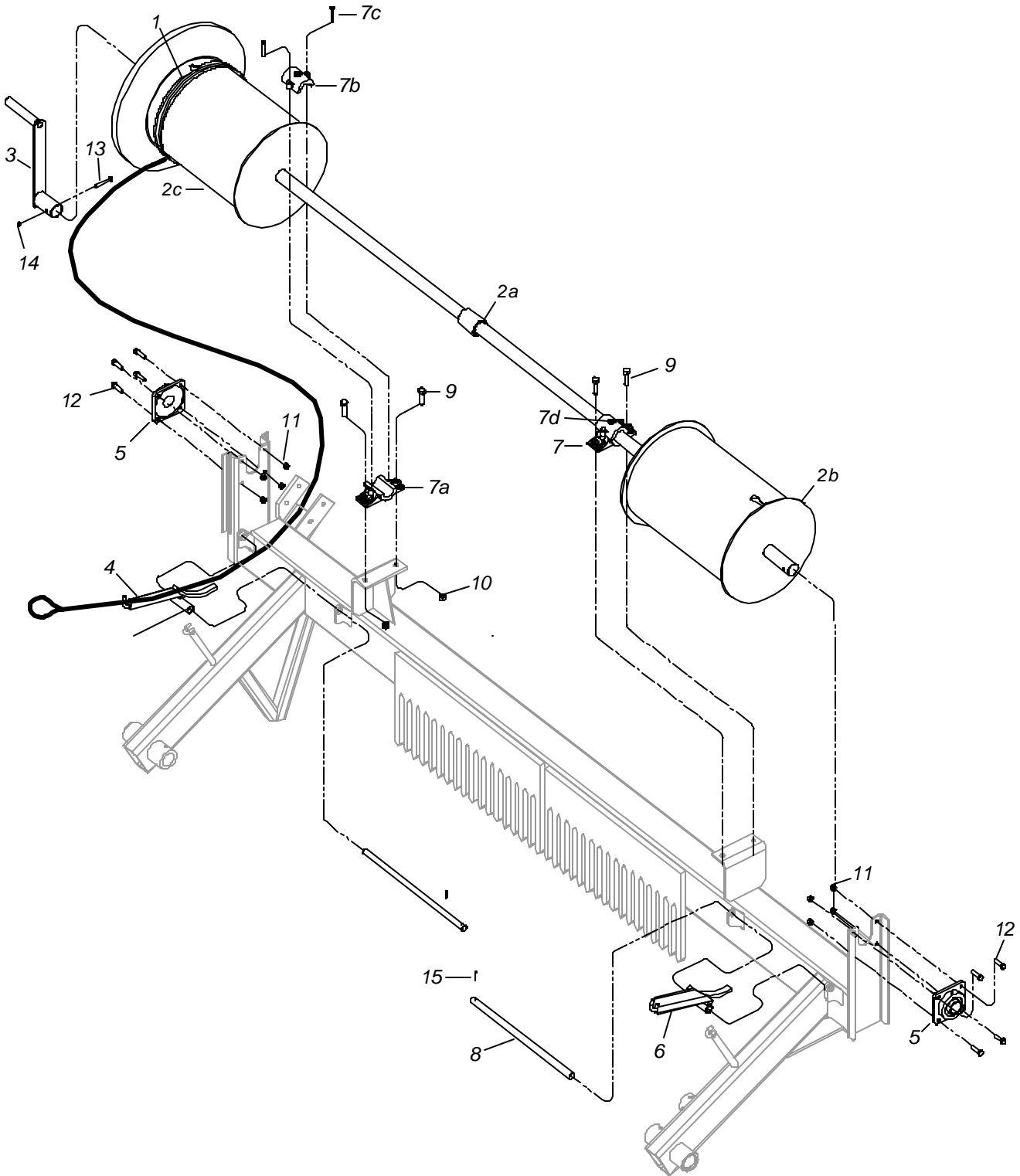

# PARTS MANUAL

## CABLE DRUM

Used On Legend  
 A - All Models    B - G6060  
 C - G6070        D - PB6000

Item#	Part#	DESCRIPTION	Qty.	Remarks
1	1590065	Wire Rope, Cable Rewind	2	B, D
	1590066	Wire Rope, Cable Rewind	2	C
2a	6003021	Coupler, Cable Drum Weld	1	A
2b	6003024	Cable Drum, Non Brake Side 8-9'	1	B, D
	6003028	Cable 10'	2	C
2c	6003025	Cable Drum, Brake Side 8-9'	1	B, D
3	1030017	Crank, Cable Rewind	1	A
4	6003014	Shoe, Cable Rewind-Right	1	A
5	1510044	Bearing	2	A
6	6003013	Shoe, Cable Rewind-Left	1	A
7	1510047	Bearing	2	A
7a	ref.	Bearing, Split Base	Ref.	
7b	ref.	Bearing, Split Top	Ref.	
7c	ref.	Capscrew, Bearing Connector	Ref.	
7d	1541637	Fitting, Grease	2	A
8	1030069	Shaft, Cable Rewind	2	B,D
	6003018	Rod, Cable Rewind	2	C
9	ref.	Capscrew, Hex Head	4	5/8-11 NC x 2-1/4 G5
10	ref.	Nut, Hex	4	5/8-11 NC Nyloc
11	ref.	Nut, Hex	8	1/2-13 NC Lock
12	ref.	Capscrew, Hex Head	8	1/2-13 NC x 1-1/4 G5
13	ref.	Capscrew, Hex Head	1	3/8-16 NC x 2-3/4
14	ref.	Nut, Hex	1	3/8-16 NC Nyloc
15	ref.	Pin, Hair	2	1/8

TUNNEL with BAG BOOM OPTION

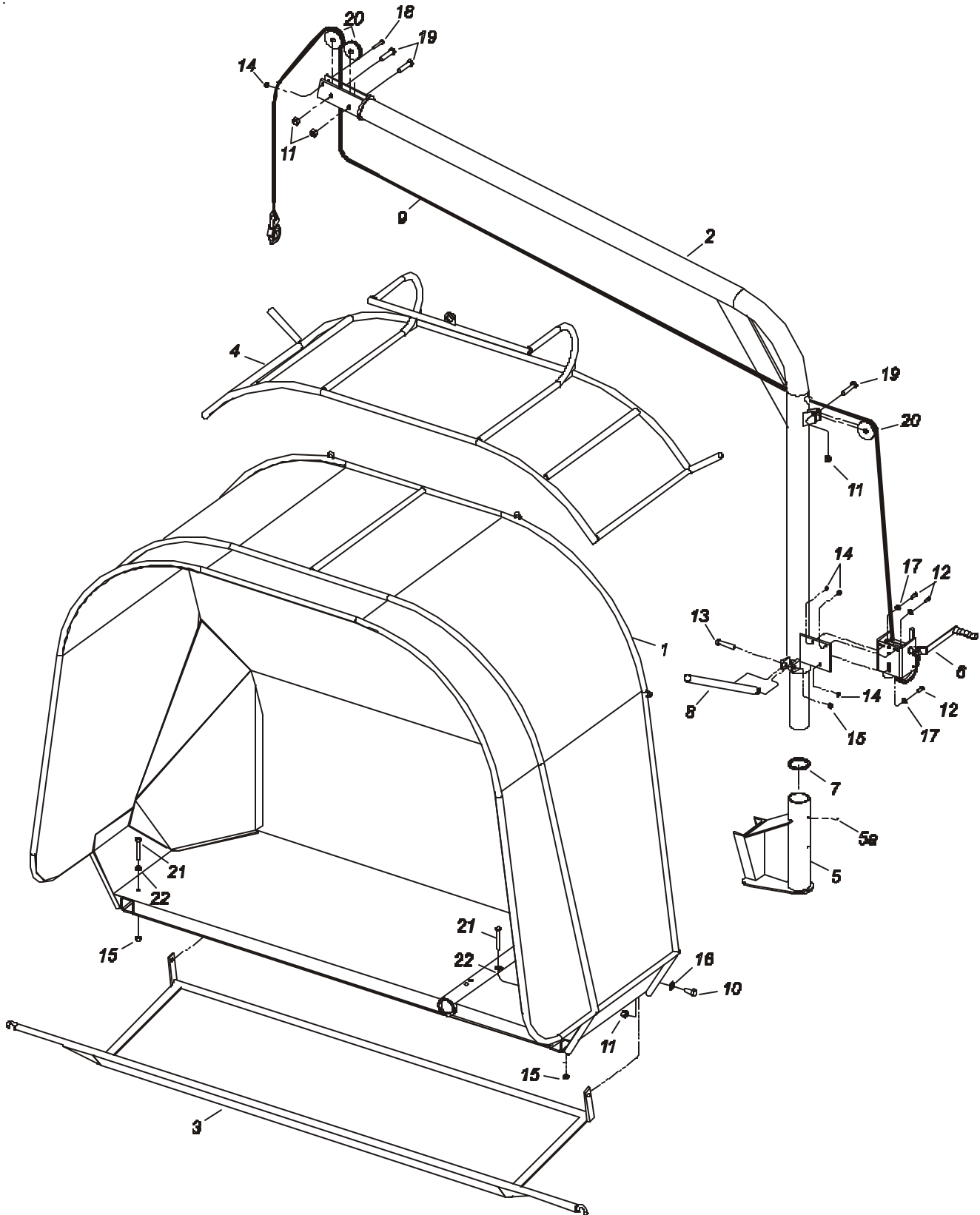

# PARTS MANUAL

## **TUNNEL with BAG BOOM OPTION**

Used On Legend  
 A - All Models    B - G6060  
 C - G6070        D - PB6000

Item#	Part#	DESCRIPTION	Qty.	Remarks
1	6006111	Tunnel, 8'	1	D
	6006109	Tunnel, 9'	1	D
2	6006001	Bag Boom Frame 8' and 9'	1	B
	6006000	Bag Boom Frame 10'	1	C
3	6006005	Pan, Bag 8' and 9'	1	B, D
	6006037	Pan, Bag 10'	1	C
4	6006012	Cradle, Bag Boom 8' and 9'	1	B, D
	6006039	Cradle, Bag Boom 10'	1	C
	6006088	Cradle, Bag Boom 9'	1	C
5	6006006	Socket, Bag Boom	1	A
5a	1541638	Fitting, Gease	2	A
6	1500602	Winch, Manual	1	A
7	1060039	Spacer, Bag Boom Bronze	1	A
8	1060085	Bar, Bag Boom Turn	1	A
9	1501691	Cable, With Hook	1	A
10	ref.	Capscrew, Hex Head	2	5/8-11 NC x 1-1/2 G5
11	ref.	Nut, Hex	4	5/8-11 NC Nyloc
12	ref.	Capscrew, Hex Head	3	3/8-16 NC x 1 G5
13	ref.	Capscrew, Hex Head	1	1/2-13 NC x 3 G5
14	ref.	Nut, Hex	4	3/8-16 NC Nyloc
15	ref.	Nut, Hex	3	1/2-13 NC Nyloc
16	ref.	Washer, Flat	2	5/8
17	ref.	Washer, Flat	3	3/8
18	ref.	Capscrew, Hex Head	1	3/8-16 NC x 2-1/2 G5
19	ref.	Capscrew, Hex Head	2	5/8-11 NC x 3 G5
20	1060036	Pulley, Bag Boom	3	A
21	ref.	Capscrew, Hex Head	2	1/2-13 NC x 3-1/2 G5
22	ref.	Washer, Flat	2	1/2

TUNNEL INTERCHANGEABLE HOOD with BAG BOOM OPTION

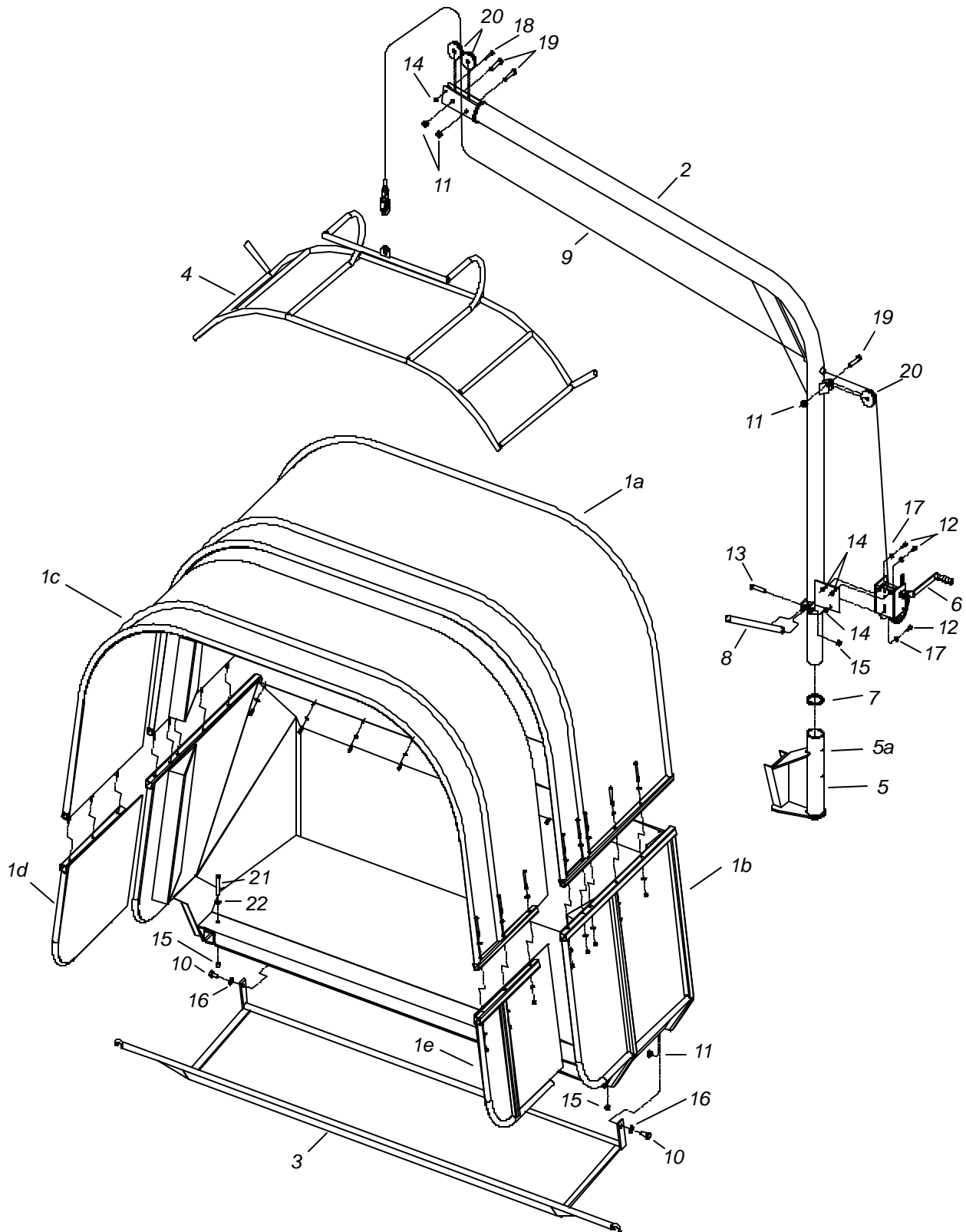

# PARTS MANUAL

## **TUNNEL INTERCHANGEABLE HOOD with BAG BOOM OPTION**

Used On Legend  
A - All Models    B - G6060  
C - G6070        D - PB6000

Item#	Part#	DESCRIPTION	Qty.	Remarks
1a	6006071	Tunnel Hood 8'	1	B
	6006072	Tunnel Hood 9'	1	B
	6006074	Tunnel Hood 9'	1	C
	6006075	Tunnel Hood 10'	1	C
1b	6006070	Tunnel Base 6060	1	B
	6006073	Tunnel Base 6070	1	C
1c	6006076	Tunnel Extension 8' x 18"	1	B
	6006077	Tunnel Extension 8' x 29"	1	B
	6006078	Tunnel Extension 9' x 18"	1	B
	6006079	Tunnel Extension 9' x 29"	1	B
	6006080	Tunnel Extension 10' x 18"	1	C
	6006081	Tunnel Extension 10' x 29"	1	C
	6006084	Tunnel Extension 9' x 18"	1	C
	6006085	Tunnel Extension 9' x 29"	1	C
1d	6006113	Tunnel Extension Base 29"	1	B, C
	6006115	Tunnel Extension Base 18"	1	B, C
1e	6006114	Tunnel Extension Base 29"	1	B, C
	6006116	Tunnel Extension Base 18"	1	B, C
2	6006001	Bag Boom Frame 8' and 9'	1	B, D
	6006000	Bag Boom Frame 10'	1	C
3	6006005	Pan, Bag 8' and 9'	1	B, D
	6006037	Pan, Bag 10'	1	C
4	6006012	Cradle, Bag Boom 8' and 9'	1	B, D
	6006089	Cradle, Bag Boom 10'	1	C
	6006088	Cradle, Bag Boom 9'	1	C
5	6006006	Socket, Bag Boom	1	A
5a	1541638	Fitting, Gease	2	A
6	1500602	Winch, Manual	1	A
7	1060039	Spacer, Bag Boom Bronze	1	A
8	1060085	Bar, Bag Boom Turn	1	A
9	1501691	Cable, With Hook	1	A
10	ref.	Capscrew, Hex Head	2	5/8-11 NC x 1-1/2 G5
11	ref.	Nut, Hex	4	5/8-11 NC Nyloc
12	ref.	Capscrew, Hex Head	3	3/8-16 NC x 1 G5
13	ref.	Capscrew, Hex Head	1	1/2-13 NC x 3 G5
14	ref.	Nut, Hex	4	3/8-16 NC Nyloc
15	ref.	Nut, Hex	3	1/2-13 NC Nyloc
16	ref.	Washer, Flat	2	5/8
17	ref.	Washer, Flat	3	3/8
18	ref.	Capscrew, Hex Head	1	3/8-16 NC x 2-1/2 G5
19	ref.	Capscrew, Hex Head	2	5/8-11 NC x 3 G5
20	1060036	Pulley, Bag Boom	3	A
21	ref.	Capscrew, Hex Head	2	1/2-13 NC x 3-1/2 G5
22	ref.	Washer, Flat	2	1/2

STANDARD CONVEYOR

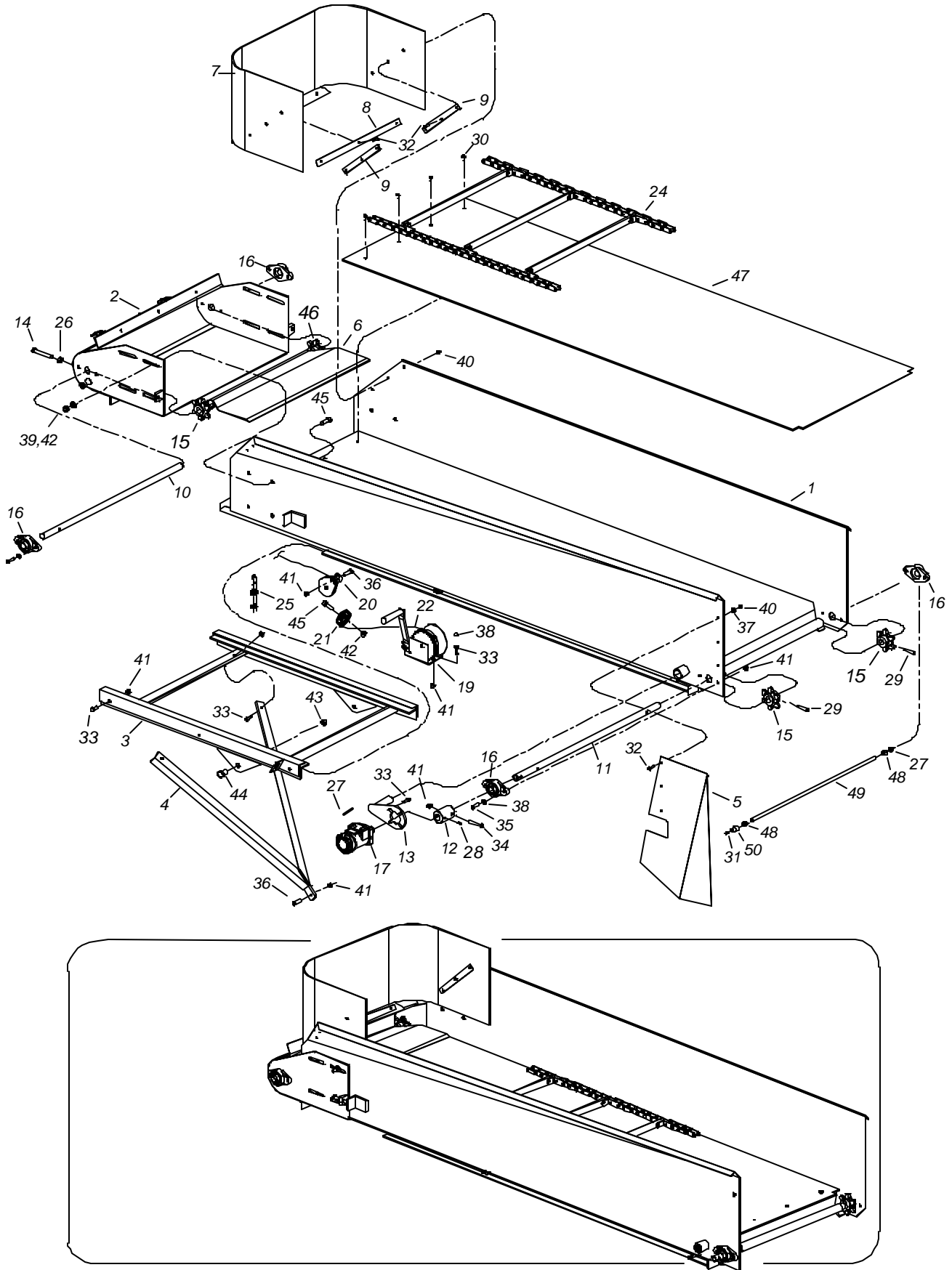



# PARTS MANUAL

## STANDARD CONVEYOR

Used On Legend  
 A - All Models    B - G6060  
 C - G6070        D - PB6000

Item#	Part#	DESCRIPTION	Qty.	Remarks
1	6008001	Conveyor, Frame	1	B, D
2	6008024	Conveyor End, Adjusting	1	B, D
3	6008007	Frame, Conveyor Track H	1	B, D
4	6008006	Stabilizer, Conveyor Angle Adjustment	1	B, D
5	6008013	Plate, Conveyor End Deflector	1	B, D
6	6008027	Guard, Conveyor Tail Shaft	1	B, D
7	6008052	Skirt, Conveyor	1	B, D
8	6008020	Strip, Conveyor Skirting Center	1	B, D
9	6008021	Bracket, Skirting-Small	2	B, D
10	6008093	Shaft, Conveyor Idle	1	B, D
11	6008092	Shaft, Conveyor Drive	1	B, D
12	6008004	Coupler, Conveyor Motor	1	B, D
13	6008011	Mount, Hydraulic Motor	1	B, D
14	ref.	Capscrew, Hex Head	2	1/2-13 NC x 6
15	1520773	Sprocket, Drive	3	B, D
16	6008088	Bearing, 2 Bolt Flange	4	B, D
17	1540898	Motor, Hydraulic	1	B, D
17a	1541780	Motor, Hydraulic	1	B, C
19	1501521	Winch, Manual	1	B, D
20	1501314	Pulley, Swivel	1	B, D
21	1501279	Pulley	1	B, D
22	1590040	Cable, Aircraft	1	B, D
23	6008018	Slat, Conveyor Chain (Not Shown)	17	B, D
24	1520318	Chain, Conveyor Complete	1	B, D
25	1590024	Clamp, Cable	2	B, D
26	ref.	Nut, Hex	2	1/2-13 Jam Nyloc
27	N/A			
28	1550192	Screw, Set	1	B, D
29	1550181	Pin, Roll	2	B, D
30	ref.	Capscrew, Hex Head	4	5/16-18 NC x 3/4 G5
31	1541638	Fitting, Grease	2	B, D
32	ref.	Capscrew, Hex Head	12	1/4-20 NC x 1 G5
33	ref.	Capscrew, Hex Head	8	3/8-16 NC x 1 G5
34	ref.	Capscrew, Hex Head	1	3/8-16 NC x 2-1/2 G5
35	ref.	Capscrew, Hex Head	8	3/8-16 NC x 1-1/4 G5
36	ref.	Capscrew, Hex Head	2	3/8-16 NC X 1-1/2 G5

(Con't next page)

# PARTS MANUAL

## CONVEYOR GROUP

Used On Legend  
 A - All Models    B - G6060  
 C - G6070        D - PB6000

Item#	Part#	DESCRIPTION	Qty.	Remarks
37	ref.	Washer, Flat	12	1/4
38	ref.	Washer, Flat	8	3/8
39	ref.	Washer, Flat	8	1/2
40	ref.	Nut, Hex	12	1/4-20 NC Lock
41	ref.	Nut, Hex	19	3/8-16 NC Lock
42	ref.	Nut, Hex	9	1/2-13 NC Lock
43	ref.	Nut, Hex	2	5/8-11 NC Nyloc
44	ref.	Capscrew, Hex Head	2	5/8-11 NC x 1 G5
45	ref.	Capscrew, Hex Head	9	1/2-13 NC x 1-1/2 G5
46	1120218	Sprocket, Idle	1	B, D
47	1501324	Polyethelene, High Density	1	B, D
48	N/A			
49	1501519	Grease Whip	1	B, D
50	N/A			
ref	6008072	Guide, Conveyor Chain - Left	1	B, D - Not Shown
ref	6008072	Guide, Conveyor Chain - right	1	B, D - Not Shown
ref	6008003	Conveyor Complete	1	B, D
ref	1501511	Fitting, Hose End Swivel		Used with Grease Whips

THIS PAGE INTENTIONALLY LEFT BLANK

SPLIT CONVEYOR

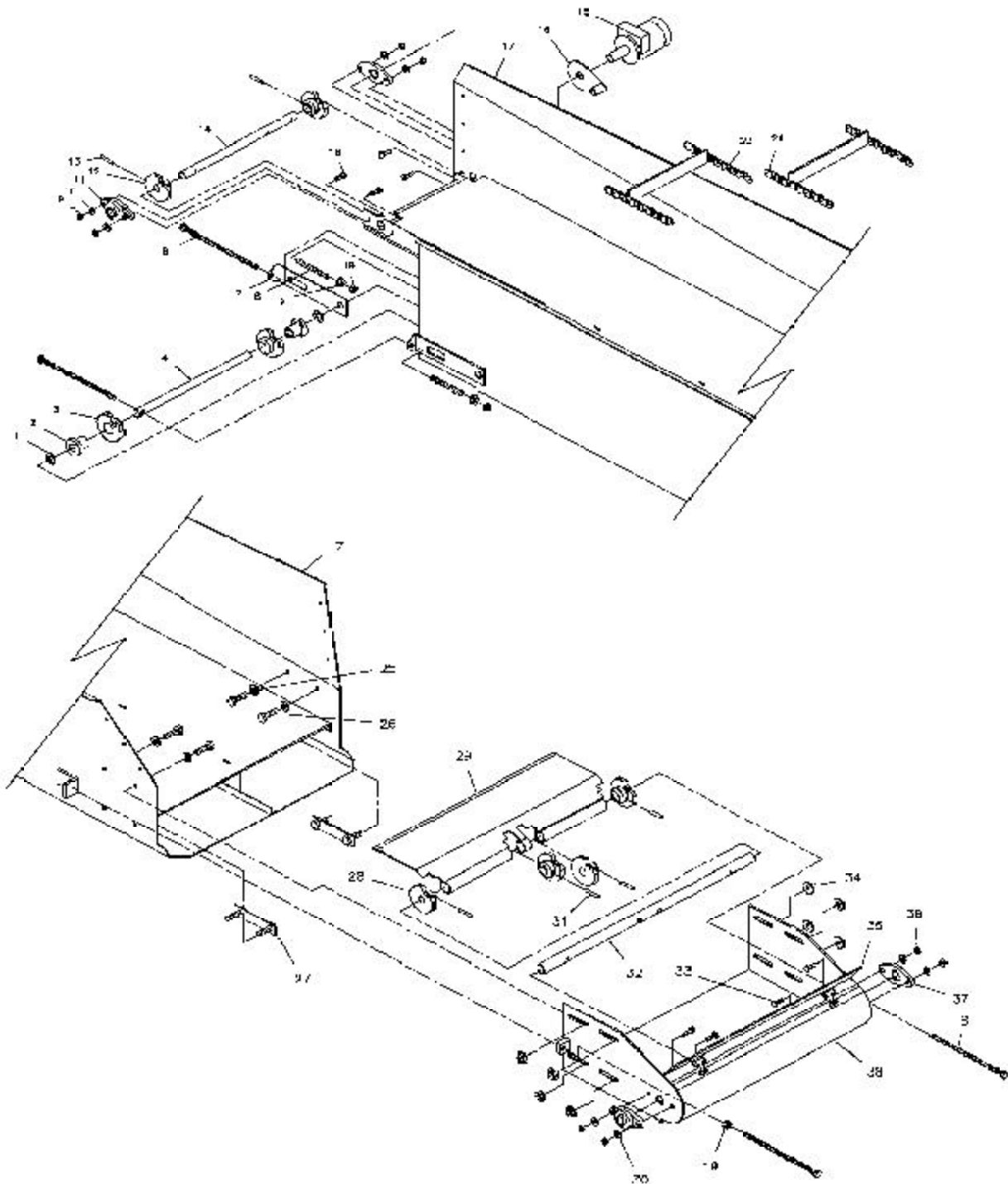

# PARTS MANUAL

## SPLIT CONVEYOR

Used On Legend  
 A - All Models    B - G6060  
 C - G6070        D - PB6000

Item#	Part#	DESCRIPTION	Qty.	Remarks
1	ref.	Washer, Flat	2	1
2	6008099	Bushing	2	Nylon 2-1/4 OD x 1
3	6008083	Sprocket	2	B, C
4	6008085	Shaft, Idle - Top	1	B, C
5	ref.	Nut, Flange	2	1/2-13 NC
6	6008086	Spring, Compression	2	B, C
7	6008080	Bracket		B, C
8	6008087	Bolt, Adjuster	4	B, C
9	ref.	Nut, Hex	4	7/16-14NC
10	N/A			
11	6008088	Bearing, 2 bolt flange	4	B, C
12	1520773	Sprocket, Drive	2	B, C
13	1550181	Pin	2	B, C
14	6008090	Shaft, drive - top	1	B, C
15	1541780	Motor, Hydraulic	1	B, C
16	6008011	Mount, Hydraulic Motor	1	B, C
17	6008084	Conveyor Complete - Split	ref	
17a	6008076	Conveyor Body Weldment	ref	
18	ref.	Capscrew, Hex	4	7/16-14nc X 1-1/4
19	ref.	Nut, Hex	4	1/2-13 NC
22	N/A			
23	6008078	Chain, split conveyor - short	1	B, C
24	6008077	Chain, split conveyor - long	1	B, C
25	ref.	Washer, Flat	4	1/2
26	ref.	Capscrew, Hex	4	1/2-13 NC x 1-1/2
27	6008091	Bracket, Adjusting & Mount	2	B, C
28	6008097	Sprocket, Idle	4	B, C
29	<del>6008098</del>	Guard, Conveyor Chain - split	1	B, C AA6008096
30	N/A			
31	ref.	Pin	4	3/8 X 2
32	6008094	Shaft, Conveyor Intermediate	1	B, C
33	ref.	Capscrew, Hex	4	7/16-14NC x 1-1/4
34	ref.	Nut, Flange	8	1/2-13NC
35	6008095	Conveyor End, Adjusting	1	B, C
36	ref.	Nut, Hex	4	7/16-14NC
37	1510261	Bearing, 1-3/8 Flange	2	B,C
38	<del>6008099</del>	Door Assembly, Conveyor w/hooks	1	B, C Use AA0901034*
ref	6008004	Coupler, Conveyor Motor	1	B, C - Not Shown
ref	6008052	Skirt, Conveyor 20 x 60	1	B, C - Not Shown
ref	6008020	Strip, Conveyor Skirting Center	1	B, C - Not Shown
ref	6008021	Strip, Conveyor Skirting Side	2	B, C - Not Shown
ref	6008072	Guide, Conveyor Chain - Left	1	B, C - Not Shown
ref	6008073	Guide, Conveyor Chain - Right	1	B, C - Not Shown

\*Conveyor Door is AA0901869

BACKSTOP

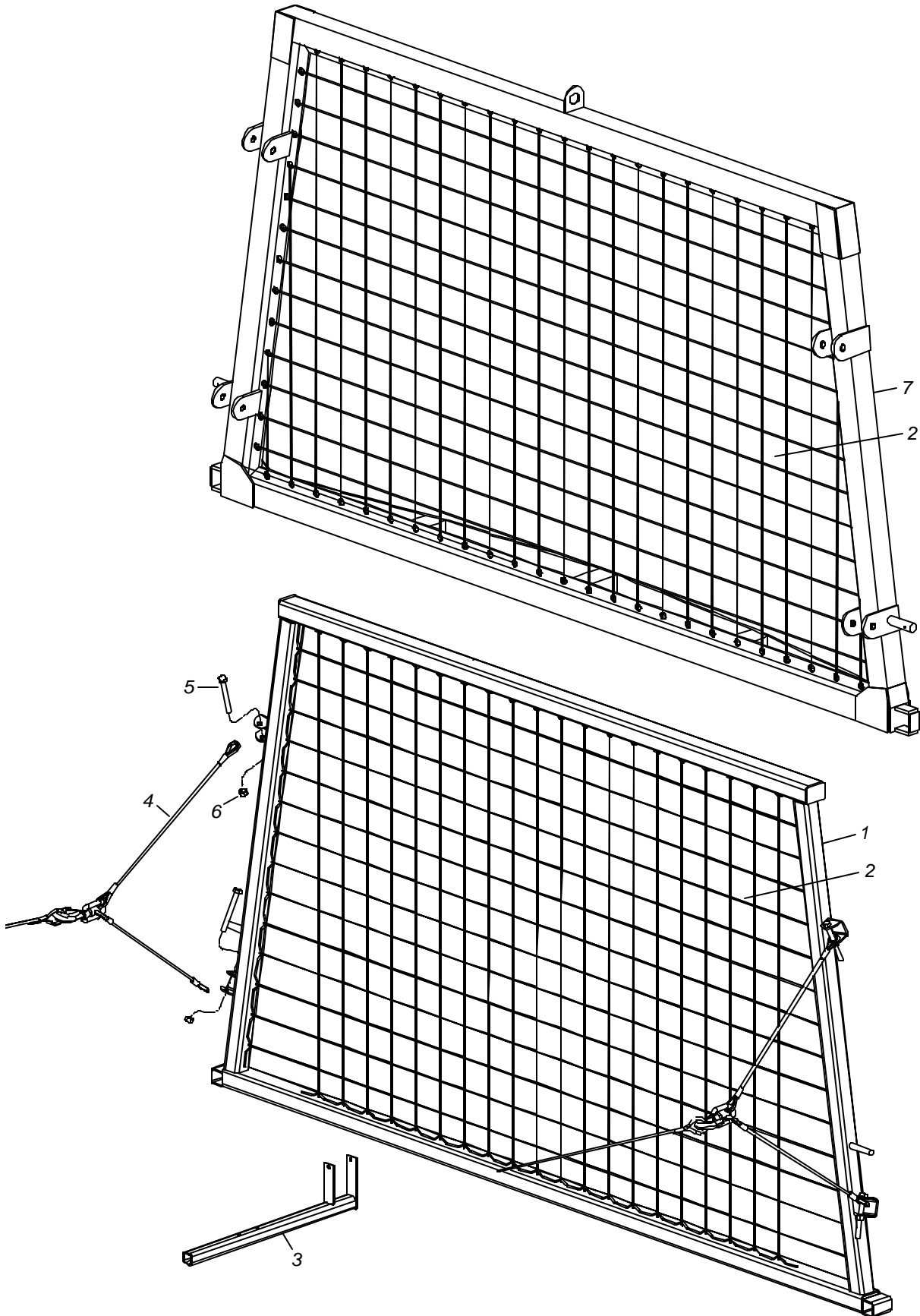

# PARTS MANUAL

## **BACKSTOP**

Used On Legend  
 A - All Models    B - G6060  
 C - G6070        D - PB6000

Item#	Part#	DESCRIPTION	Qty.	Remarks
1	1090014	Backstop, Frame, Steel 8 & 9 Foot	1	B, D
	1090034	Backstop, Frame, Alum 8 & 9 Foot	1	B
	1090008	Backstop, Frame, Steel 10 Foot	1	C
	1090031	Backstop, Frame, Alum 10 Foot	1	C
2	1560005	Rope, Backstop 300'	1	B, D
	1560006	Rope, Backstop 400'	1	C
3	1090026	Support, Backstop Transport Locking	2	B, D
	6006063	Support, Backstop Transport Locking	2	C
	6006112	Support, Backstop Transport Alumin	2	B
	1060160	Support, Backstop Transport Alumin	2	C
4	1500412	Sling, Backstop Cable	2	A
5	ref.	Capscrew, Hex Head	4	3/4-10 NC x 6-1/2 G5
6	ref.	Nut, Hex	4	3/4-10 NC Nyloc

HYDRAULICS -G6060A - PB6000

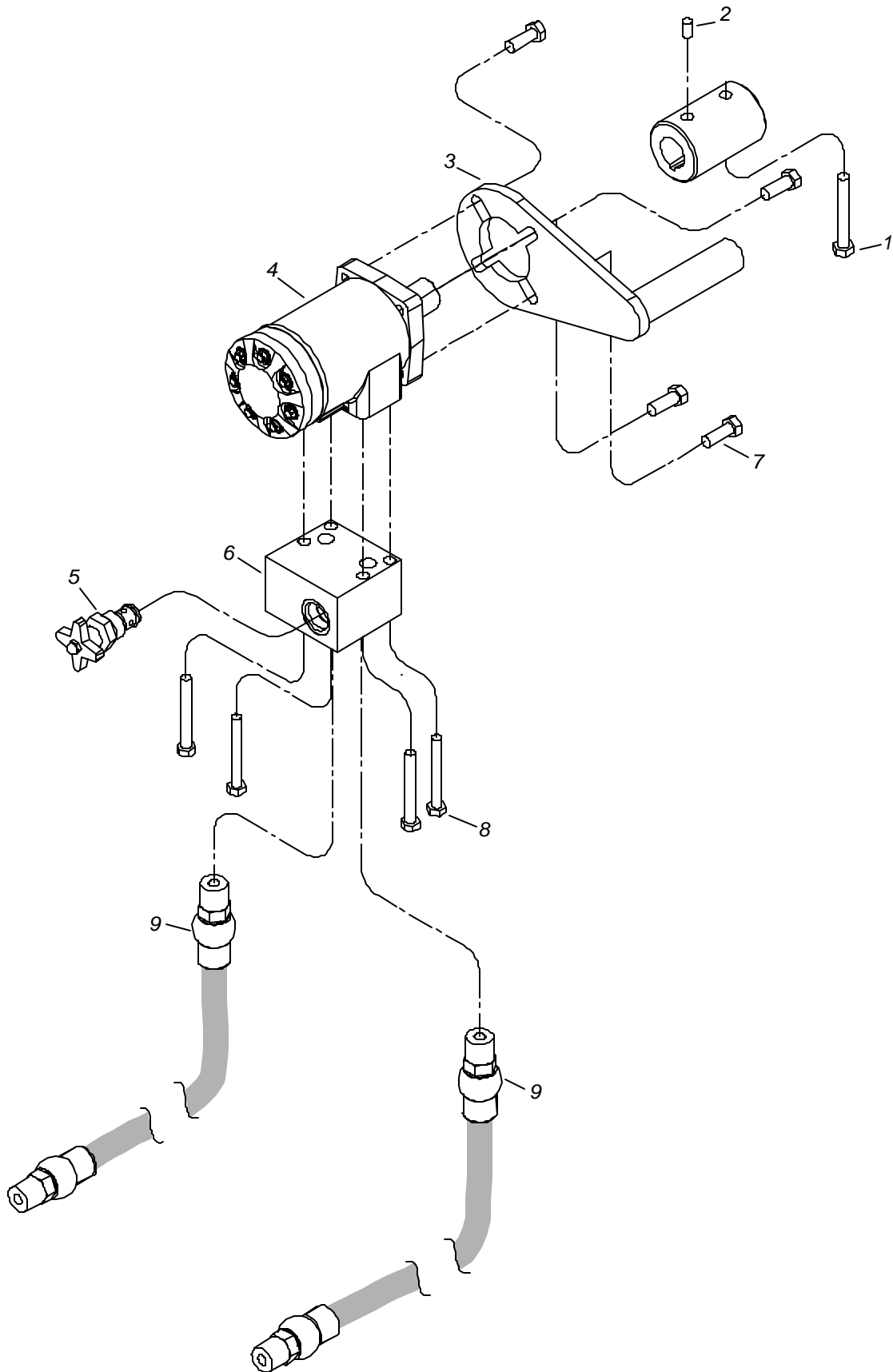



# PARTS MANUAL

## HYDRAULICS - G6060A - PB6000

Item#	Part#	DESCRIPTION	Qty.	Remarks
1	ref.	Cap Screw, Hex Head	1	3/8-16 UNC X 2-1/2 G5
2	ref.	Screw, Set	1	3/8 UNC x 1/2
3	6008011	Mount, Hydraulic Motor (Conveyor)	1	
4	1540898	Motor, Hydraulic	1	
5	1540025	Valve, Pressure Control Relief	1	
6	1541237	Valve, Conveyor Motor	1	
7	ref.	Cap Screw, Hex Head	4	3/8-16 NC x 1 G5
8	ref.	Cap Screw, Hex Head	4	5/16-18 x 2-1/2 G5
9	6010002	Kit, Hydraulic Hose	1	
ref	1540116	Quick Coupler Fitting	2	

HYDRAULIC PACKAGE OPTION - G6060B & G6070B

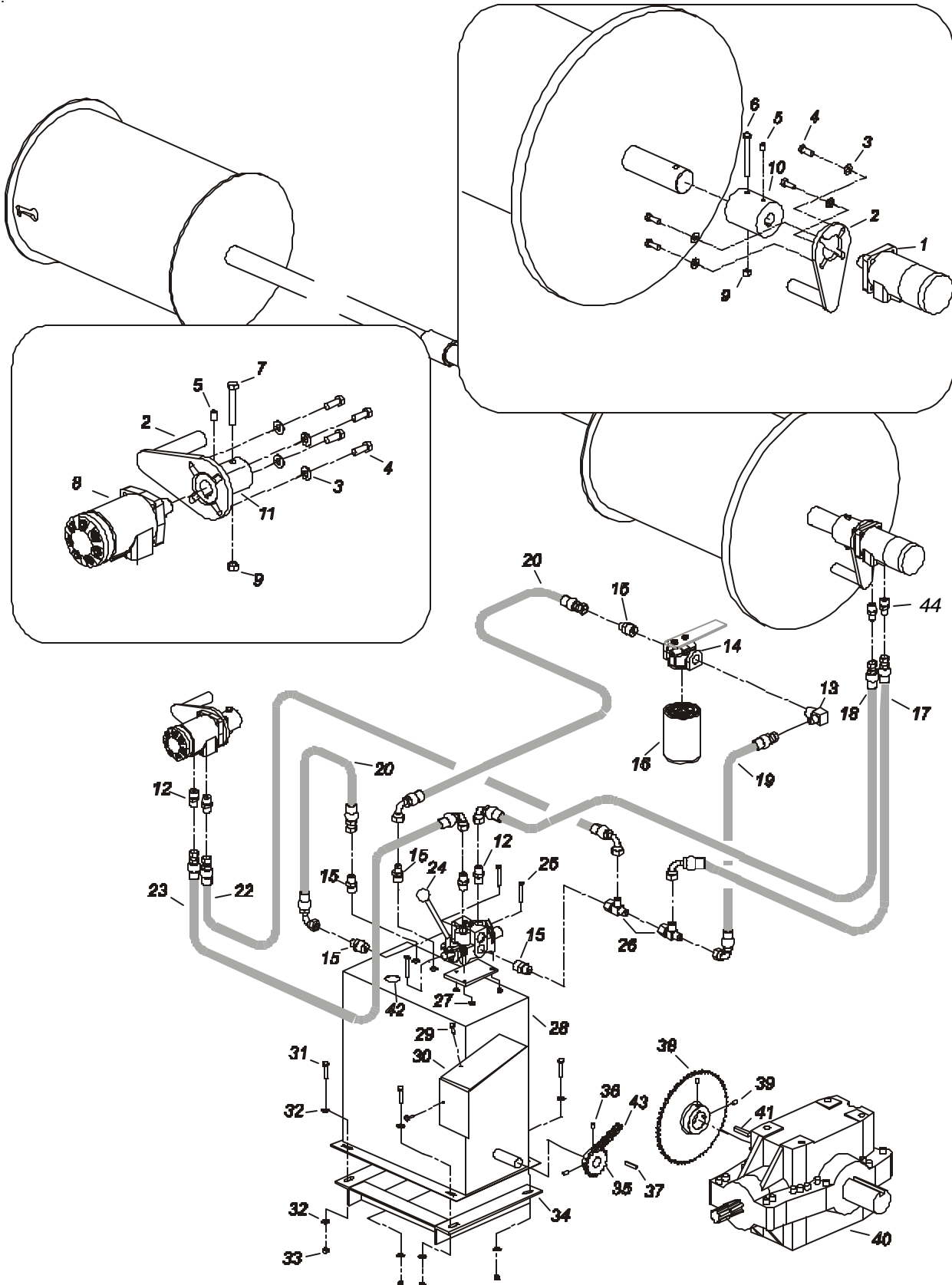

## PARTS MANUAL

### HYDRAULIC PACKAGE OPTION - G6060B & G6070B

Item#	Part#	DESCRIPTION	Qty.	Remarks
1	N/A			
2	6008011	Mount, Hydraulic Motor	1	
3	ref.	Washer, Flat	4	3/8 NOM
4	ref.	Cap Screw, Hex Head	4	3/8-16 UNC x 1 G5
5	ref.	Screw, Set	1	3/8-16 UNC x 1/2
6	N/A			
7	ref.	Cap Screw, Hex Head	1	3/8-16 UNC x 2-1/2 G5
8	1541780	Motor, Hydraulic	1	
9	ref.	Nut, Hex	1	3/8-16 UNC Nyloc
10	N/A			
11	6008004	Coupling, Conveyor Motor	1	
12	1541649	Fitting, Hydraulic	4	
13	1541758	Fitting, Hydraulic	1	
14	1541757	Base, Filter	1	
15	1541759	Fitting, Hydraulic	1	
16	1540167	Filter, Hydraulic Oil	1	
17	N/A			
18	N/A			
19	1541609	Hose Assembly 15"	1	
20	1541503	Hose Assembly 15" (2 hoses)	1	
22	1541609	Hose Assembly 70"	1	
23	1541609	Hose Assembly 66"	1	
24	1541648	Valve, Brand	1	
25	ref.	Cap Screw, Hex Head	3	1/4-20 UNC x 2 G5
26	N/A			
27	ref.	Nut, Hex	3	1/4-20 UNC Lock
28	1541032	Pump, Hydraulic With Tank	1	
29	ref.	Screw	2	1/4 Self Tap x 1
30	6012003	Guard, Hydraulic Pump Chain	1	
31	ref.	Cap Screw, Hex Head	4	5/16-18 UNC x 1-1/2 G5
32	ref.	Washer, Flat	8	5/16 NOM
33	ref.	Nut, Hex	4	5/16-18 UNC Lock
34	6012001	Mount, Hydraulic Pump Williams	1	
35	1520759	Sprocket	1	
36	1550262	Set Screw, Sprocket	2	
37	ref.	Key	1	1/4 x 1/4 x 2
38	1520760	Sprocket	1	
39	ref.	Set Screw, Sprocket	2	3/8 x 1/2 SS
40	1520050	Gearbox	1	
41	ref.	Key	1	3/8 x 3/8 x 2
42	1500686	Cap, Breather Williams Pump (Not Shown)	1	
43	1520761	Chain, Roller	1	
44	N/A			

HYDRAULIC PACKAGE OPTION - G6060C

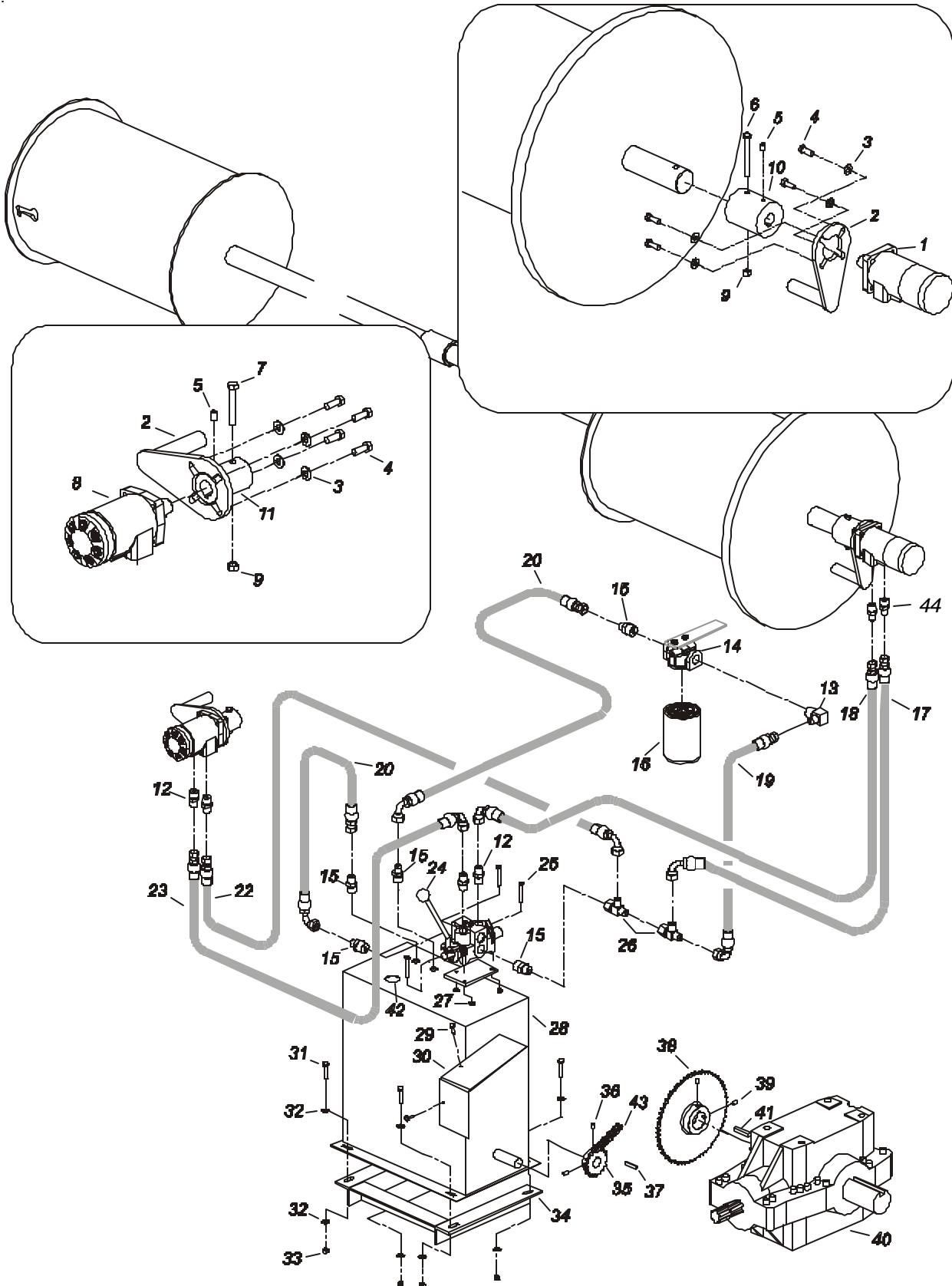

## PARTS MANUAL

### HYDRAULIC PACKAGE OPTION - G6060C

Item#	Part#	DESCRIPTION	Qty.	Remarks
1	1541054	Motor, Hydraulic	1	
2	6008011	Mount, Hydraulic Motor	1	
3	ref.	Washer, Flat	4	3/8 NOM
4	ref.	Cap Screw, Hex Head	4	3/8-16 UNC x 1 G5
5	ref.	Screw, Set	1	3/8-16 UNC x 1/2
6	ref.	Cap Screw, Hex Head	1	3/8-16 UNC x 3-1/2 G5
7	ref.	Cap Screw, Hex Head	1	3/8-16 UNC x 2-1/2 G5
8	1541780	Motor, Hydraulic	1	
9	ref	Nut, Hex	1	3/8-16 UNC Nyloc
10	1030014	Coupling, Cable Rewind	1	
11	6008004	Coupling, Conveyor Motor	1	
12	1541649	Fitting, Hydraulic	6	
13	1541758	Fitting, Hydraulic	1	
14	1541757	Base, Filter	1	
15	1541759	Fitting, Hydraulic	3	
16	1540167	Filter, Hydraulic Oil	1	
17	1541504	Hose Assembly 99"	1	
18	1541504	Hose Assembly 108"	1	
19	1541609	Hose Assembly 15"	1	
20	1541503	Hose Assembly 15" (2 hoses)	1	
22	1541609	Hose Assembly 70"	1	
23	1541609	Hose Assembly 66"	1	
24	1541648	Valve, Brand	1	
25	ref.	Cap Screw, Hex Head	3	1/4-20 UNC x 2 G5
26	1541608	Fitting, Hydraulic	2	
27	ref.	Nut, Hex	3	1/4-20 UNC Lock
28	1541032	Pump, Hydraulic With Tank	1	
29	ref.	Screw	2	1/4 Self Tap x 1
30	6012003	Guard, Hydraulic Pump Chain	1	
31	ref.	Cap Screw, Hex Head	4	5/16-18 UNC x 1-1/2 G5
32	ref.	Washer, Flat	8	5/16 NOM
33	ref.	Nut, Hex	4	5/16-18 UNC Lock
34	6012001	Mount, Hydraulic Pump Williams	1	
35	1520759	Sprocket	1	
36	1550262	Set Screw, Sprocket	2	
37	ref.	Key	1	1/4 x 1/4 x 2
38	1520760	Sprocket	1	
39	ref.	Set Screw, Sprocket	2	3/8 x 1/2 SS
40	1520050	Gearbox	1	
41	ref.	Key	1	3/8 x 3/8 x 2
42	1500686	Cap, Breather Williams Pump (Not Shown)	1	
43	1520761	Chain, Roller	1	
44	1541605	Fitting, Hydraulic	4	

HYDRAULIC PACKAGE OPTION - G6070C

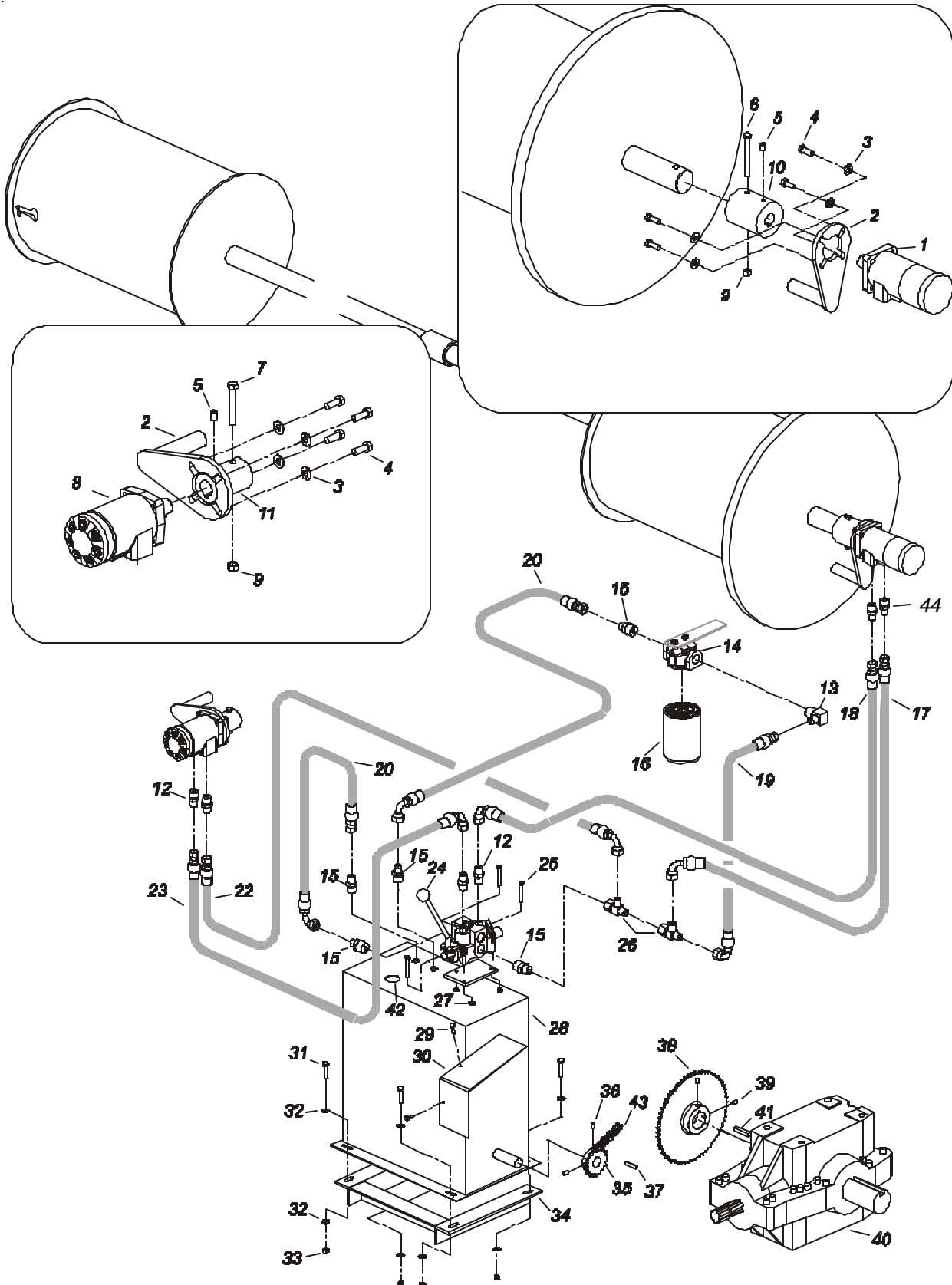

## PARTS MANUAL

### HYDRAULIC PACKAGE OPTION - G6070C

Item#	Part#	DESCRIPTION	Qty.	Remarks
1	1541054	Motor, Hydraulic	1	
2	6008011	Mount, Hydraulic Motor	1	
3	ref.	Washer, Flat	4	3/8 NOM
4	ref.	Cap Screw, Hex Head	4	3/8-16 UNC x 1 G5
5	ref.	Screw, Set	2	3/8-16 UNC x 1/2
6	ref.	Cap Screw, Hex Head	1	3/8-16 UNC x 3-1/2 G5
7	ref.	Cap Screw, Hex Head	1	3/8-16 UNC x 2-1/2 G5
8	1541780	Motor, Hydraulic	1	
9	ref	Nut, Hex	1	3/8-16 UNC Nyloc
10	1030014	Coupling, Cable Rewind	1	
11	6008004	Coupling, Conveyor Motor	1	
12	1541649	Fitting, Hydraulic	6	
13	1541758	Fitting, Hydraulic	1	
14	1541757	Base, Filter	1	
15	1541759	Fitting, Hydraulic	3	
16	1540167	Filter, Hydraulic Oil	1	
17	1541604	Hose Assembly 99"	1	
18	1541604	Hose Assembly 108"	1	
19	1541609	Hose Assembly 15"	1	
20	1541503	Hose Assembly 15" (2 hoses)	1	
22	1541609	Hose Assembly 70"	1	
23	1541609	Hose Assembly 66"	1	
24	1541648	Valve, Brand	1	
25	ref.	Cap Screw, Hex Head	3	1/4-20 UNC x 2 G5
26	1541608	Fitting, Hydraulic	2	
27	ref.	Nut, Hex	3	1/4-20 UNC Lock
28	1541032	Pump, Hydraulic With Tank	1	
29	ref.	Screw	2	1/4 Self Tap x 1
30	6012003	Guard, Hydraulic Pump Chain	1	
31	ref.	Cap Screw, Hex Head	4	5/16-18 UNC x 1-1/2 G5
32	ref.	Washer, Flat	8	5/16 NOM
33	ref.	Nut, Hex	4	5/16-18 UNC Lock
34	6012001	Mount, Hydraulic Pump Williams	1	
35	1520759	Sprocket	1	
36	1550262	Set Screw, Sprocket	2	
37	ref.	Key	1	1/4 x 1/4 x 2
38	1520760	Sprocket	1	
39	ref.	Set Screw, Sprocket	2	3/8 x 1/2 SS
40	1520050	Gearbox	1	
41	ref.	Key	1	3/8 x 3/8 x 2
42	1500686	Cap, Breather Williams Pump (Not Shown)	1	
43	1520761	Chain, Roller	1	
44	1541605	Fitting, Hydraulic	2	

HYDRAULIC CONVEYOR LIFT

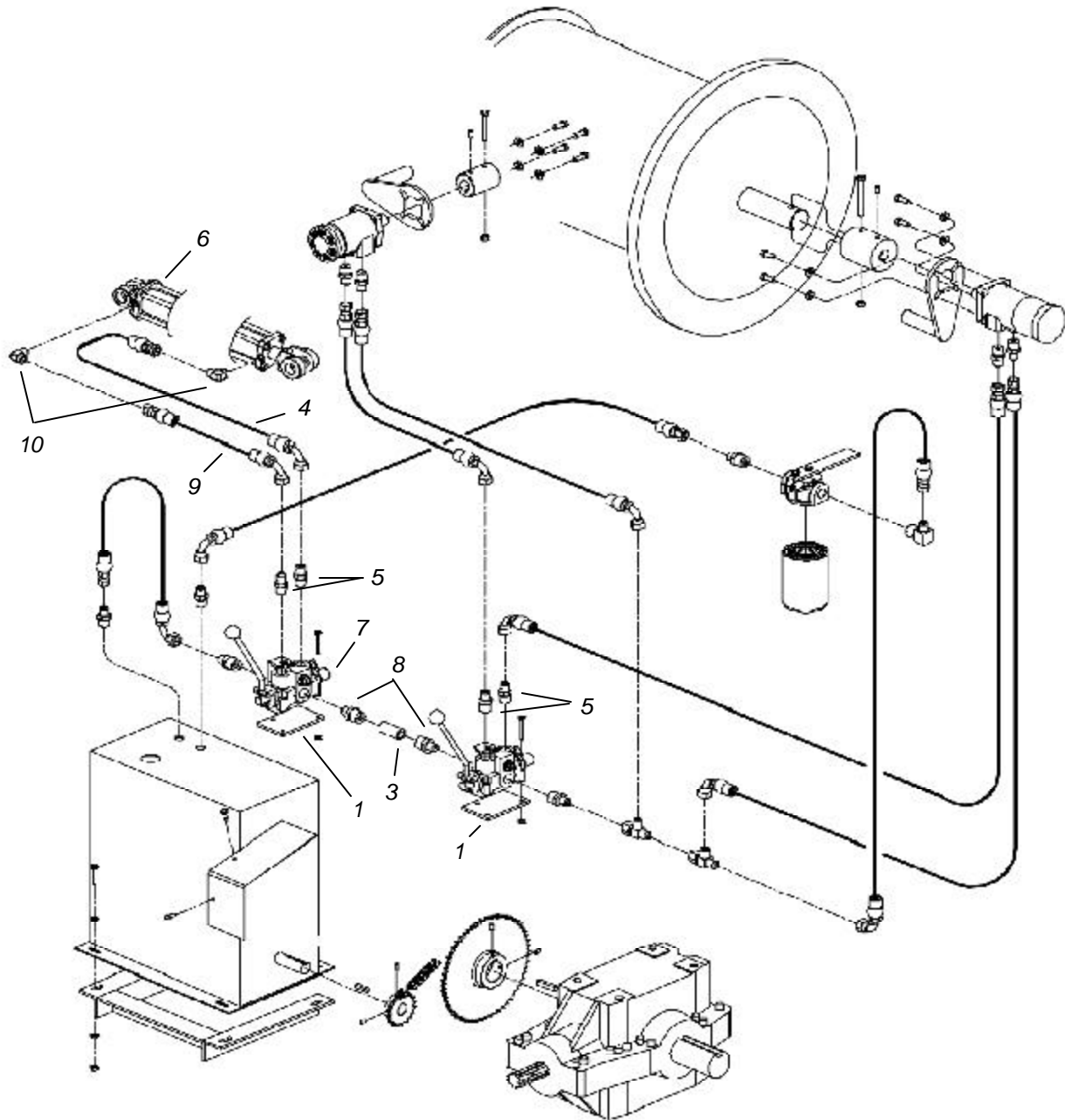



## PARTS MANUAL

### HYDRAULIC CONVEYOR LIFT

Used On Legend  
 A - All Models    B - G6060  
 C - G6070        D - PB6000

Item#	Part#	DESCRIPTION	Qty.	Remarks
1	1120006	Bracket, Valve Mount	2	B, C
2	1120035	Mount, Hyd. Cylinder (Not Shown)	1	B, C
3	1541192	Fitting, Hyudraulic	1	B, C
4	1541616	Hose, Assembly	1	B, C
5	1541649	Fitting, Hydraulic	2	B, C
6	1541755	Cylinder, Hydraulic	1	B, C
7	1541777	Valve, Hydraulic	1	B, C
8	1541782	Fitting, Hydraulic	2	B, C
9	1541806	Hose, Assembly	1	B, C
10	1541893	Fitting, Hydraulic	2	B, C
ref	6008074	Mount, Hydraulic Cylinder	1	B, C (Not Shown)
ref	2101001	Tubing	2	B, C (Not Shown)
ref	8000009	Options Kit	1	B, C (Not Shown)

**SINGLE CABLE DRUM BRAKE ASSEMBLY**

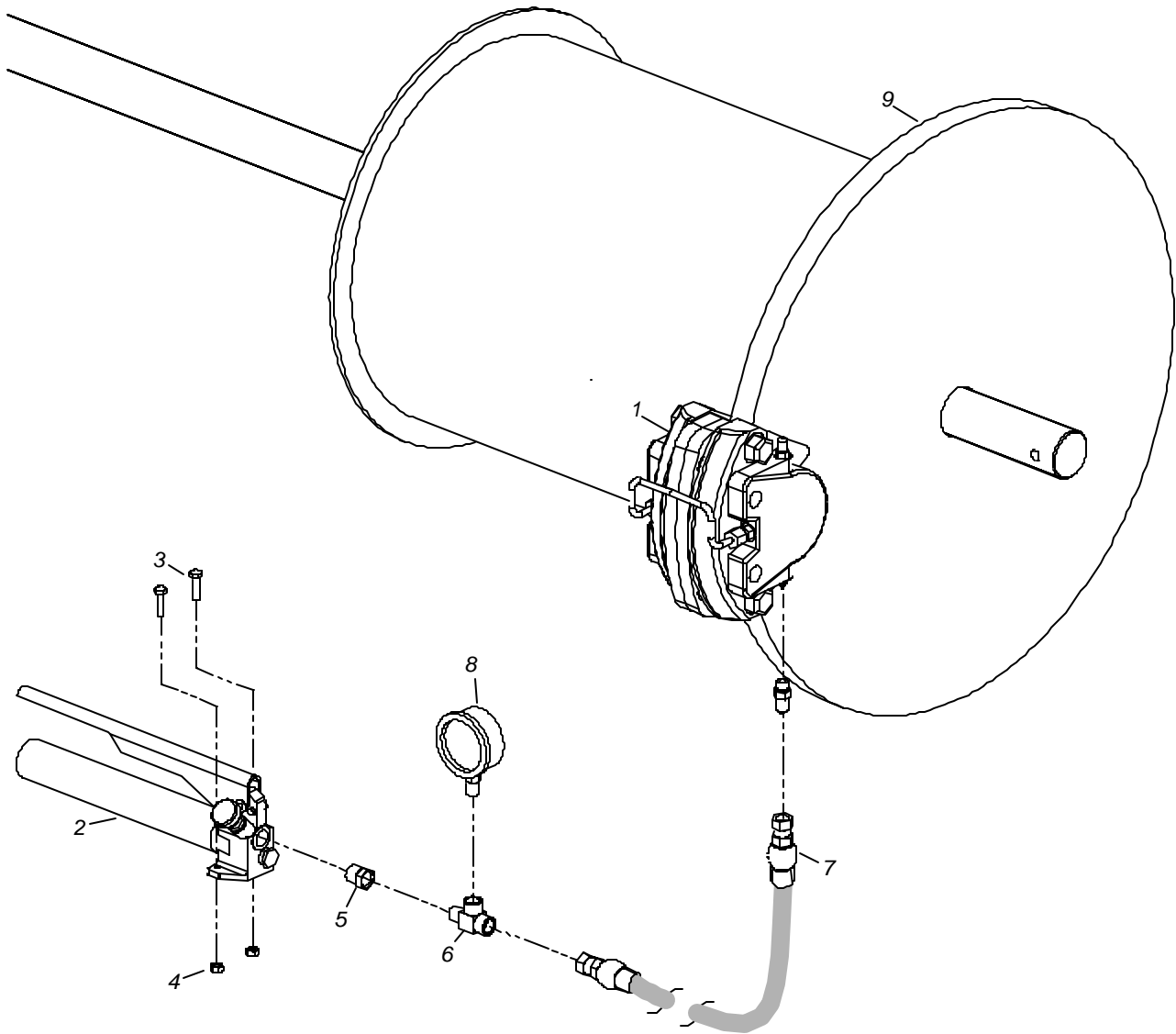

## PARTS MANUAL

### **SINGLE CABLE DRUM BRAKE ASSEMBLY**

Used On Legend  
 A - All Models    B - G6060  
 C - G6070        D - PB6000

Item#	Part#	DESCRIPTION	Qty.	Remarks
1	1501348	Brake, Mico Disk	1	B, D
2	1502224	Pump, Hand	1	B
	1541231	Pump, Hand	1	D
3	ref.	Capscrew, Hex Head	2	1/4-20 UNC x 1 G5
4	ref.	Nut, Hex Lock	2	1/4-20 UNC
5	1542021	Fitting, Hydraulic	1	A
6	1540481	Fitting, Hydraulic	1	A
7	1541282	Hose Assy, Hyd. Brake Pump	1	B, D
8	1500142	Gauge, Hydraulic Pressure	1	A
9	ref.	Cable Drum Assembly	1	
10	1541283	Fitting, Hydraulic	1	A
11	1500294	Pad, Brake (not shown)		A

DOUBLE CABLE DRUM BRAKE ASSEMBLY

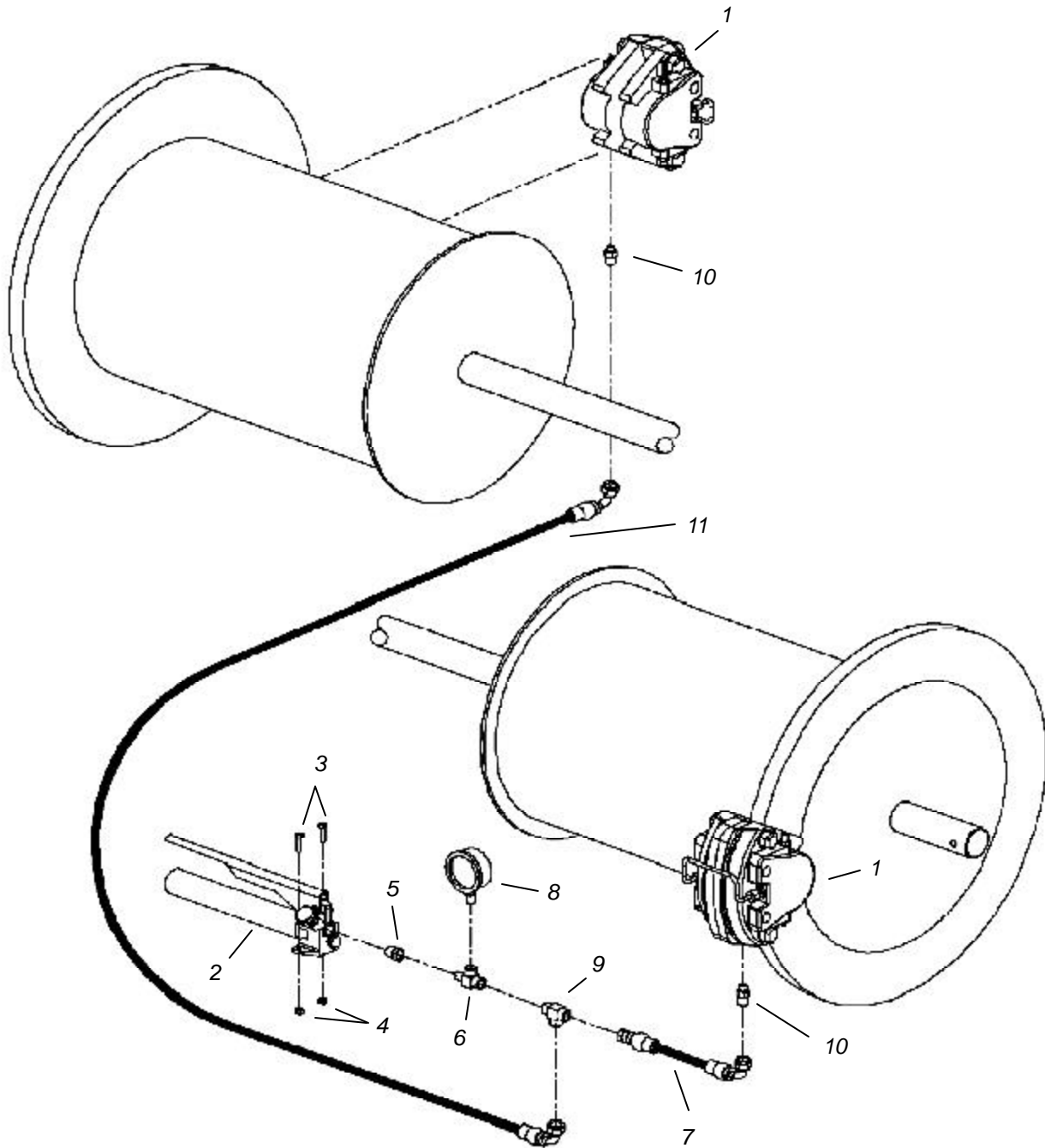

## PARTS MANUAL

### **DOUBLE CABLE DRUM BRAKE ASSEMBLY**

Used On Legend  
 A - All Models    B - G6060  
 C - G6070        D - PB6000

Item#	Part#	DESCRIPTION	Qty.	Remarks
1	1501348	Brake, Mico Disk	2	C
2	1502224	Pump, Hand	1	C
3	ref.	Capscrew, Hex Head	2	1/4-20 UNC x 1 G5
4	ref.	Nut, Hex Lock	2	1/4-20 UNC
5	1542021	Fitting, Hydraulic	1	A
6	1540481	Fitting, Hydraulic	1	A
7	1541948	Hose Assembly Hyd. Brake	1	C
8	1500142	Gauge, Hydraulic Pressure	1	A
9	1540734	Fitting, Hydraulic	1	C
10	1541283	Fitting, Hydraulic	2	C
11	1541949	Hose Assembly Hyd. Brake	1	C
ref	1541404	Hose Kit	1	C (Items 7 & 11)

GANDY

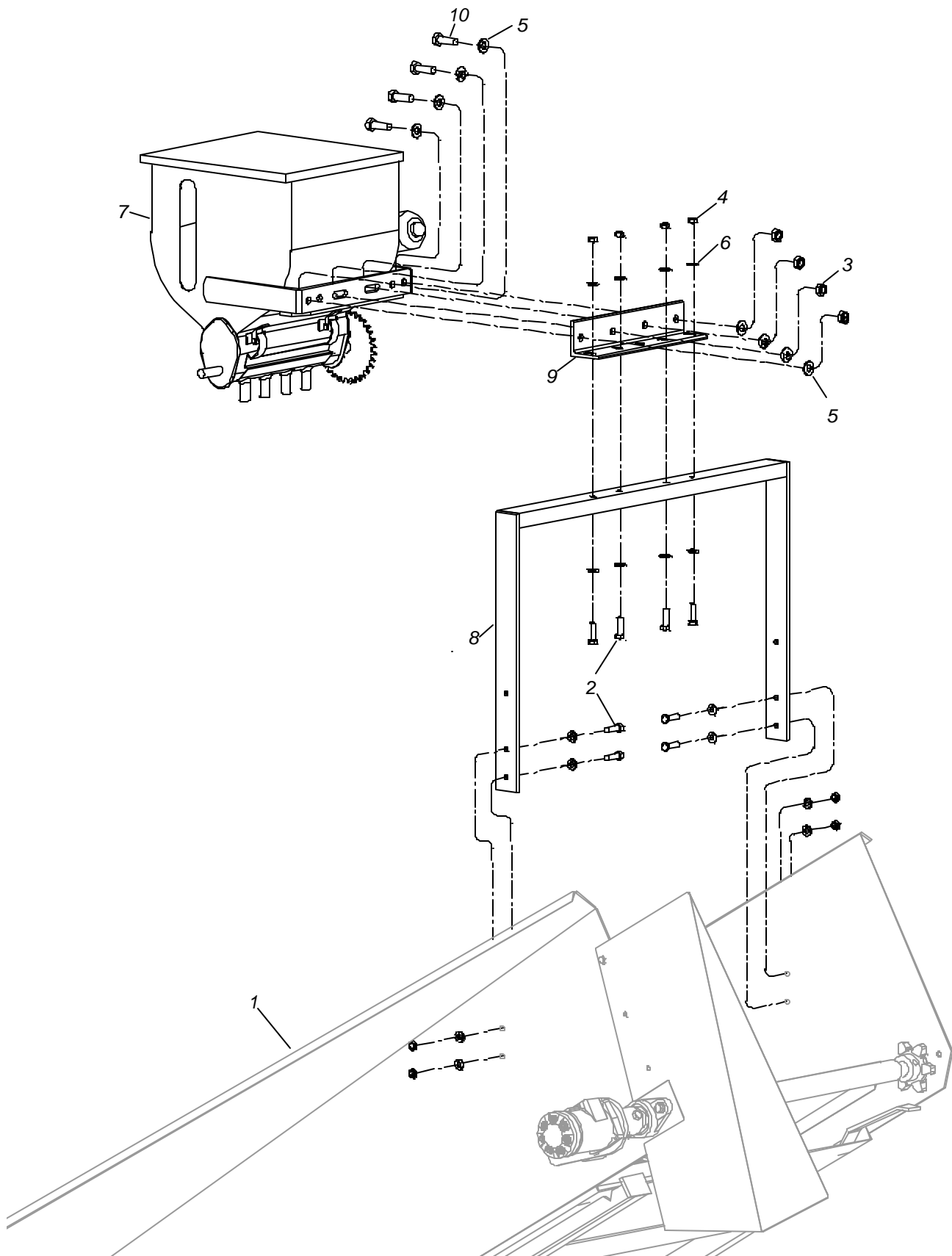

# PARTS MANUAL

## **GANDY**

Used On Legend  
 A - All Models    B - G6060  
 C - G6070        D - PB6000

Item#	Part#	DESCRIPTION	Qty.	Remarks
1	ref.	Conveyor		
2	ref.	Cap Screw, Hex Head	8	3/8-16 NC x 1 G5
3	ref.	Nut, Hex	4	1/2-13 NC
4	ref.	Nut, Hex	8	3/8-16 NC
5	ref.	Washer	8	1/2
6	ref.	Washer	16	3/8
7	1500005	Gandy Applicator 4 Hole	1	B, C
	1500004	Gandy Applicator 2 Hole	1	B, C
8	6012006	Mount, Gandy Applicator	1	B, C
9	1120486	Bracket, Gandy Applicator	1	A
10	ref.	Cap Screw, Hex Head	4	1/2-13 NC x 1-1/4 G5
ref	8000003	Gandy Kit	1	

MISCELLANEOUS

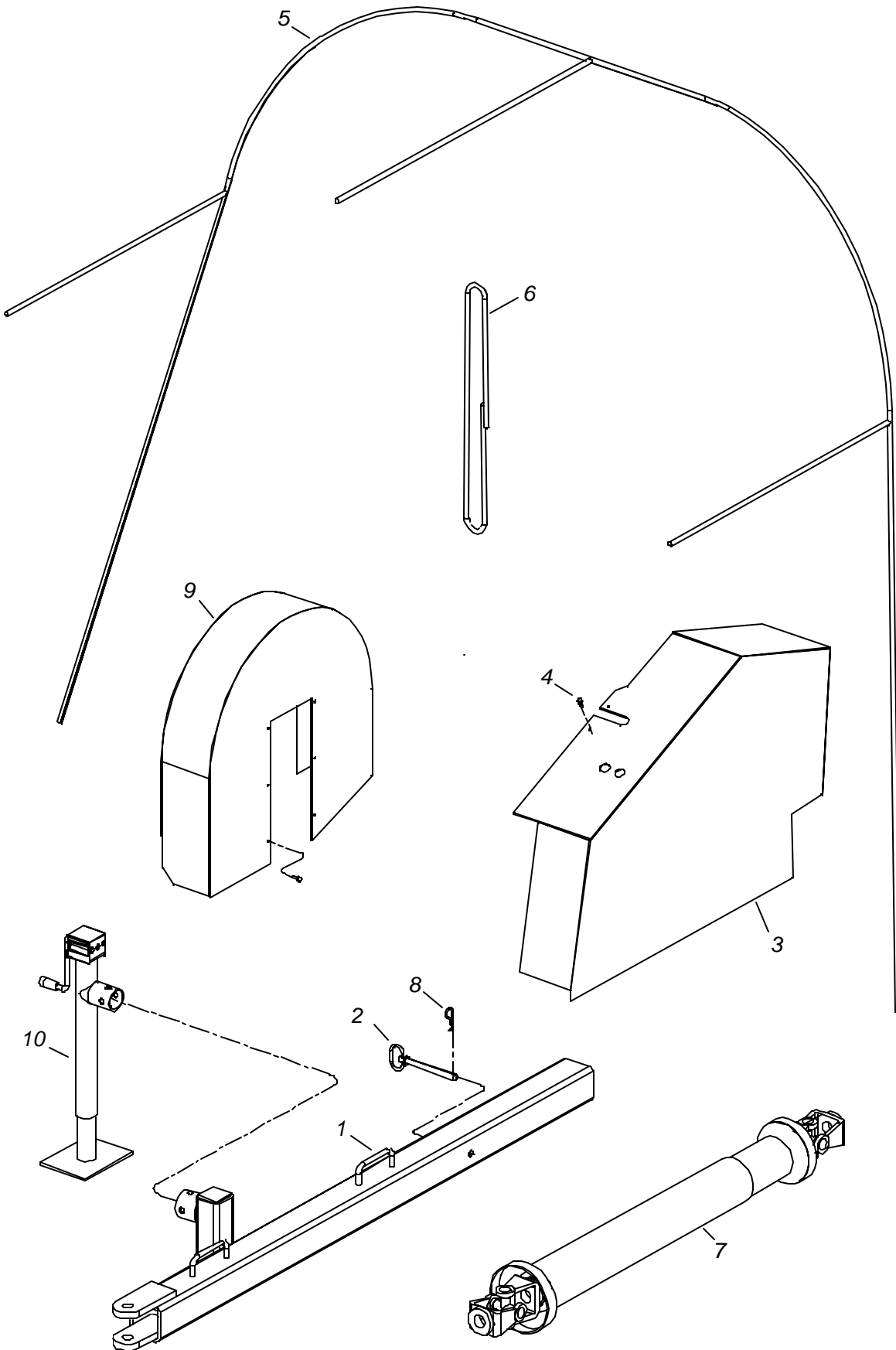



# PARTS MANUAL

## MISCELLANEOUS

Used On Legend  
 A - All Models    B - G6060  
 C - G6070        D - PB6000

Item#	Part#	DESCRIPTION	Qty.	Remarks
1	6011009	Hitch, Field 8'-9'	1	B, D
	6011010	Hitch, Field 10'	1	C
2	1550172	Pin, Hitch	1	A
3	6002031	Guard, Rotor Chain	1	B, D
	6002040	Guard, Rotor Chain	1	C
4	ref.	Screw, Slotted Hex Head Self Tapping	8	#14 x 3/4
5	1560000	Bungee Cord, Tunnel	1	A
6	1560001	Bungee Cord, Bag Pan	2	A
7	1500386	Shaft, PTO	1	B, D
	1500385	Shaft, PTO	1	C
8	1550169	Pin, Hair	1	A
9	6003030	Guard, Cable Drum Brake	1	B, D
		Guard, Cable Drum Brake	2	C
10	1501398	Jack, Manual 15" Square Mount	1	A
	1560004	Bungee Cord Kit	1	A (Items 5 & 6)

**THIS PAGE INTENTIONALLY LEFT BLANK**